

AKC Agility Judge's Guidelines

Amended to March 2020

Published by The American Kennel Club



AMERICAN
KENNEL CLUB®

AKC Agility Judges Guidelines

Table of Contents

Chapter 1	Judge’s Responsibilities, Protocol, and Procedures.....	3
Chapter 2	Judge’s Duties Prior to the Trial.....	20
Chapter 3	Course Design.....	24
Chapter 4	Preparing to Judge – Day of Trial.....	38
Chapter 5	Judging.....	55
Chapter 6	FAST Class.....	74
Chapter 7	Time to Beat (T2B).....	84
Chapter 8	Premier.....	88
Chapter 9	What-ifs While Judging.....	91
Chapter 10	Judge’s Duties After Judging.....	103
Chapter 11	FEO and Fix N Go On.....	109
Appendix	Diagrams and Illustrations.....	112

CHAPTER 1

JUDGE'S RESPONSIBILITIES, PROTOCOL, AND PROCEDURES

Remember: You make it work!

As an American Kennel Club agility judge, you are an essential part of the program. The AKC agility system needs your dedication and expertise to function properly. We, the AKC Director of Agility and Field Representatives, believe these judging guidelines will make it easier for you to do your job and to contribute to the sport of agility in a positive manner.

This set of guidelines is meant to supplement and provide further explanation of the agility regulations. It does not repeat the regulations, nor is it intended to change or alter the regulations in any way; however, its contents are a valid extension of the regulations and should be adhered to as such. You should be thoroughly familiar with these guidelines, as well as all the AKC's rules, regulations for agility trials, and policies if you:

- Are an approved or provisional judge
- Have accepted match judging assignments
- Plan to attend an AKC Judging Seminar

SECTION 1. Responsibilities as a Judge

Responsibilities to the sport of purebred dogs: Approval to judge carries with it the full endorsement of the American Kennel Club. Whether judging at a licensed trial or sanctioned match or engaging in any dog-related activity (including but not limited to exhibiting), judges must be cognizant of their responsibility to the sport.

Judges have a responsibility to work with the AKC staff and its Field Representatives to ensure that the standards of the AKC agility program are maintained. As a judge, you are required to meet these key criteria:

1. Knowledge: Through experience and continuing study, you must demonstrate sound knowledge of the sport of agility. Good judges never stop learning about the sport of agility. To ensure that all judges are knowledgeable, agility judges are required to attend and meet the requirements of a continuing education seminar at least once every 3 years.

Excellent sources of information for agility judges to stay current include:

- *The AKC Gazette* (<http://www.akc.org/pubs/gazette/>)
- The AKC web site (www.AKC.org)

- Judge's Newsletters and blog
(<https://akcagilityjudges.wordpress.com>)

2. Procedure: You must demonstrate good course design, sound judging procedure, good decision-making skills, common sense, and efficient ring procedure. A judge who does this will earn the confidence of exhibitors and spectators alike.

3. Impartiality: It is essential that exhibitors have full faith in the impartiality and competence of the judge. There is no room for even the suggestion that anything other than the performance of the dog in the ring is involved in the judge's decisions.

General responsibilities: An agility judge's tasks include:

- Corresponding with the club in a timely manner
- Designing the courses and submitting them for approval
- Setting the proper atmosphere at the trial to project the attitude that agility is a fun sport
- Ensuring that the course is built correctly
- Removing all safety hazards related to the equipment and the ring area
- Measuring dogs without a valid height card or form to ensure that all dogs jump in the correct height divisions
- Determining and controlling the ring procedures
- Judging each dog's performance
- Verifying that scores, course yardages, and Standard Course Times (SCT's) are recorded accurately and that the official catalog is signed (certified) and initialed
 - Judges must make sure the Certification page in the catalog has the correct number of Qs listed before signing. An easy way to do this is to keep a running total of your Qs while reviewing scribe sheets throughout the day.
- Ensuring that only approved courses are used at the trial for which they were designed

Responsibilities to exhibitors: Each exhibitor has paid an entry fee for the purpose of competing and having his or her dog's performance evaluated. Judges are expected to conduct themselves in a professional manner and to be friendly and courteous to all who enter the ring. Without exhibitors, there would be no trials. For every experienced exhibitor, there are many newcomers who have less experience with the regulations and typical show procedures that will look to you for guidance.

Responsibilities to spectators: Spectators form their opinion of the sport

through seeing the actions of the judge, the handlers, and the dogs. Care must be taken to avoid any action that might reflect poorly on the sport. Judges should work to maintain spectator appeal in the sport, while keeping foremost in mind the welfare and safety of the exhibitors and their dogs.

SECTION 2. Protocol

Ethics: Judges must possess and project an unwavering air of integrity and ethical behavior that maintains the reputation of the AKC and the impression that agility trials are fairly and properly judged. With common sense, judges can easily avoid situations that might raise ethical questions. Judges are presumed to be honest, competent, and dedicated. Nevertheless, it is all too easy for a judge to find himself or herself in uncomfortable or even inappropriate situations. These guidelines cannot cover every situation. They can, however, help judges avoid improprieties, real or perceived.

Some ethical rules are clear. For example:

- Never accept any payments or gifts, or anything that could be perceived as a payment or gift, for past or future placements, qualifying scores, or measurements.
- Advise potential exhibitors not to enter under you when their presence or the presence of their dogs might give the impression of unfair advantage. This may include, for instance, a person with whom you co-own dogs or your employer or employee.
- Do not use your status as a judge at a trial at which you are judging to promote seminars or sales of dog food or to hand out written material for such promotion. Do not sell equipment or merchandise on a day that you are judging.
- Judges are not allowed to conduct training or handling seminars of any kind for the club or exhibitors on the day prior to judging. To avoid any appearance of conflict of interest, judges should extend this period to at least one week prior to judging. Any day following the end of a trial or set of trials is allowed.
- The internet can pose challenges for a judge. If a judge corresponds with an exhibitor after a trial regarding a call or situation, that correspondence should remain private between the judge and the exhibitor. Judges must be very careful when posting messages to lists or websites. Denigration toward another judge, club, organization or the AKC is prohibited.

These are only examples. The key is to avoid situations that might give the impression of impropriety. There will always be gray areas that could cause problems. Ask yourself whether what is happening, however innocent, maintains an outward appearance of propriety.

The AKC recognizes that you cannot control who enters a trial. This does not diminish the importance of appearances. Everything possible must be done to keep your reputation above reproach. Appropriate action by the AKC will be taken for any ethical violation.

Social functions: If a club holding a show or trial holds a dinner or social function, it is recommended that the judge(s) attend. If exhibitors who might appear in your ring will be present, take extra care to avoid any appearance of impropriety during these functions.

Training and exhibiting: All judges start in the sport as exhibitors and trainers. It is natural to want to continue these activities after becoming a judge. It is acceptable to exhibit or have your dogs exhibited at trials at which you are not judging. Because it would give the impression of impropriety, it is not permissible for your spouse, family member, relative, or household member to enter their dogs or any dogs they co-own in an agility trial on the day that you are judging. You, as the judge, are not allowed to exhibit nor have your dog exhibited on the day that you are judging. Additionally, your dog or any dog co-owned by you may not be exhibited in conformation, obedience, or any other AKC venue on the day that you are judging if the show or trial is on the same show grounds.

Judges must be prudent in how and when they exhibit. They must demonstrate the utmost in decorum and sportsmanship. Judges who exhibit should expect to be subject to special scrutiny. It is inappropriate and unprofessional for an exhibitor who is also a judge, regardless of his or her experience, to verbally override or second-guess the judge of record, including “double judging” outside the ring. This type of behavior is subject to disciplinary action by the judge of record and/or the AKC. The judge of record has complete control of how the course is set, how the ring is administered, and how the performance of the dog is judged. The judge of record shall not be subjected to additional course tweaking, “double judging,” or interference of ring personnel by any exhibitor or judge, as these are misconductable offenses. An experienced judge can make helpful suggestions to a judge of record if their expertise is requested.

Exhibiting in other AKC events: Judges (including provisional judges) may enter the “A” class in other AKC events if otherwise eligible.

Judge's attitude: As a judge, your attitude strongly affects the atmosphere of the trial. Thus, it is important that you be both pleasant and friendly. You should convey the impression that you want the dogs and handlers to succeed and, indeed, you should. It is your responsibility to design appropriately challenging courses and officiate over them correctly. If you do this properly, then you should be pleased to watch dogs perform successfully on your courses.

Because you are responsible for so many different aspects of the event, it is easy to overlook details. Since any number of details can have a large impact on a class, ranging from safety to a misunderstanding of the course that is to be performed, you should listen carefully to suggestions and comments made by the exhibitors. Remember that they are looking at the course from an entirely different perspective than you are. Even if you decide not to act upon a comment or suggestion, giving it careful consideration goes a long way in the eyes of the competitors.

Accepting assignments: As stated in the regulations, a judge may not accept an assignment that is within 30 days and 200 miles of a previously accepted assignment, with the exception of single breed specialties. Judges must check the mileage and number of days between trials when accepting assignments and signing contracts.

Judges must promptly return telephone calls or emails (accepting or declining) from clubs wishing to hire them. This will allow the club to either finalize their plans or continue to search for another judge.

Require clubs to give you a written contract or submit your own to the club. Their request should clearly specify the class(es) and date(s) you are being asked to judge. Promptly acknowledge all contracts, again in writing, with your judge's number, and keep accurate records of assignments you accept. Judges must communicate with the Trial Chairman to aid in planning the judging schedule (class order) that is to be mailed out to the exhibitors. This judging schedule will set the entire order of judging for the weekend. The class order and start times listed for any class(es) **must not** be changed on the day of the trial.

Judges should understand that in accepting an assignment, they are committing themselves to the show-giving club for the entire day. Their travel plans should not be predicated on arriving late or on leaving early to get transportation home or to another show. Rushing exhibitors in order to catch a flight or leave earlier is unacceptable and grossly inconsiderate to those who have paid to

have their performance judged and is subject to disciplinary action.

As entry patterns have changed in some areas of the country, clubs are looking to drop a judge when entries are below the number needed for the number of judges contracted. ALL judges for the trial must agree to the change, not just the judge being dropped. Often when a judge is dropped that leaves the judge(s) left on the assignment with minimal time to create additional courses for the weekend. Due to the remaining judge(s) own personal schedules this may not be something the judge(s) is prepared to do. This judge also has the right to decline the change in assignment if they do not feel the change in the terms of their judging assignment works for them. Clubs may offer to purchase courses from the judge that has agreed to be dropped. All terms of a judging assignment should be spelled out in the contract with the judge(s). These terms should include how the club and judge will handle a reduction in the number of judges for the trial.

Provisional judges are required to submit a request to judge to the Director of Agility **prior** to accepting any judging assignment. At the Novice/Open provisional judging level, a minimum of two satisfactory supervisions are required before consideration is made to move the judge to the Excellent provisional judging level. At the Excellent provisional judging level, a minimum of one satisfactory supervision is required before consideration is made to move the judge to the fully approved judging level. These conditions are separate from the course design requirements and a judge may be required to remain on provisional course design status until the Director of Agility feels the obligation for gaining knowledge and practical experience has been met. An Agility Field Rep may be required to be present at any or all provisional assignments.

Transportation: Judges shall not travel to or from shows or stay with anyone who is likely to be exhibiting or handling under them. Transportation to the show grounds from a hotel, motel, or airport is not considered travel.

Expenses: When you accept an assignment, clearly inform the club officials what your fees will be. Expenses must be discussed and put into the contract so that the club will not be surprised by a larger-than-anticipated bill on the day of the trial. This is a contract between you and the club. The more specific details you and the club include in the contract, the less the potential for misunderstandings. These details might include who will arrange for transportation and accommodations (smoking or non-smoking rooms), dietary restrictions, and what expenses will be reimbursed, such as meals, parking, and course copies if applicable. It is also important to discuss when reimbursement will take place for items such as airfare that is

usually purchased weeks in advance of the travel date. This is an important consideration and a courtesy to the club. If you sign a contract, you and the club are responsible for abiding by its conditions. Clubs cannot be made responsible for the costs of boarding a judge's dog(s).

Proper attire: All judges shall wear suitable attire. Business casual dress is highly recommended. It is important for a judge to maintain a proper and professional appearance and not be confused with the exhibitors. When an agility trial is held in conjunction with a conformation show or obedience trial, the agility judge is **required** to maintain an even higher level of dress, approximately matching that of the standard level of dress for judges of conformation and obedience, weather conditions allowing.

During periods of extreme hot weather, judges are permitted to wear warm weather clothing while judging. This policy applies to male and female judges alike. Please remember that collared shirts should be worn while you are judging.

- Judges may only wear shorts at agility-only trials. (Trials that are in conjunction with breed shows require more formal dress).
- Shorts must be clean and in good condition.
- The length of the shorts should be no shorter than just above the knee.
- A belt should be worn if the pants are so designed.
- For women, sleeveless shirts and dresses are permitted.
- No cut-off shorts or blue jeans material shorts are permitted.
- No "short" shorts or tight shorts (including but not limited to Spandex, Lycra, and bicycle or running type shorts) are permitted.
- No baggy "parachute" material shorts are permitted.
- No tank top shirts are permitted.
- Clogs, strapless sandals and certain dress shoes are not permitted since they do not allow a judge to move about the course in a quick, safe manner, or achieve the proper judging position on the course to make the correct calls.

When selecting your judging attire, understand that the judge is in the ring to evaluate the team performance, not to be the center of attention; however, the exhibitors should be able to recognize that you are the judge by more than just your name tag.

Smoking, eating, and drinking: Smoking is permissible only between classes, provided it does not delay judging. Judges, exhibitors, and ring crew may not smoke in the ring. Judges must comply with all no-smoking regulations of a facility or show grounds. Judges and ring crew may not eat or drink in the course area (except that water is allowed in the ring.)

Bottled water can be conveniently hidden under a nearby cone, or tucked under the A-frame to be available to the judge between jump heights or during bar setting. If a drink other than water is necessary, it should be attended to between classes or at jump height changes away from the course area.

Special awards: The club may offer high-in-trial or other special awards. It is up to the club or show committee to determine the basis for these awards. Judges shall not become involved with determining the criteria for any special awards, including high-in-trial awards. High-in-trial awards are discouraged due to the difficulty in providing a completely fair evaluation between the jump heights and class levels. Some clubs will still choose to have a high-in-trial award and will list it in their premium. Determination of the method used for awarding high-in-trial should be left to the show committee, and this method should be known and understood by the show committee and the score table prior to the start of the trial. *At no time shall a judge hold a runoff for this award.*

SECTION 3. Procedures

Change of address: Judges are responsible for promptly notifying the AKC office, AKC Director of Agility, and the AKC Field Representative who is responsible for review of their course designs, of any change in address, telephone and facsimile numbers, and e-mail address. The change will be reflected in the Judges Directory on the AKC website.

Fitness to judge: Judges are expected to be physically and mentally capable of performing the functions necessary to properly evaluate the dogs and handlers as they move quickly around the course.

This means that judges must have:

- The flexibility to measure dogs
- The dexterity to move at a sufficient speed and distance to adhere to the schedule of the trial-giving club and AKC policy
- The visual acuity, correctable by eyeglasses or contact lenses, to be able to judge dogs at an appropriate distance
- The capability to do all the necessary paperwork and course setting

When a judge can no longer properly perform the duties of a judge, he or she does the position of judge and the sport of agility a disservice by continuing to accept assignments. The AKC has a Judge Emeritus program to honor judges who have served the sport faithfully and wish to retire. If the judge wishes to return to fully approved judging status from the emeritus program, he or she will be required to attend and pass all requirements at a full judging seminar.

Inability to fulfill a judging assignment: If you find that you cannot fulfill an assignment because of illness, weather-related travel delays, or any other serious occurrence, immediately notify the Trial Chairman, Trial Secretary/Superintendent, or both, by telephone, overnight letter, telegram, facsimile, or e-mail.

The closer you are to the actual trial date, the more important it is for you to explore all means of communication until you get a hold of the party who can start looking for a replacement for you.

Additionally, The AKC Director of Agility or an AKC Agility Field Representative should be contacted so that he or she can help facilitate the process of replacing you on the judging panel, if necessary.

The procedure for replacing a judge **at a trial** due to illness or weather related travel is as follows:

- Once a judge is no longer able to judge, the trial chairman shall ask those exhibiting to be a replacement judge based on the following hierarchy:
 1. Any fully approved judge(s) present at the trial;
 2. Any provisional judge(s);
 3. Anyone who has attended a full judging seminar;
 4. and finally, the most experienced exhibitor.
- At the time the replacement judge starts judging, he or she becomes a judge of record and can no longer exhibit that day, nor can any of their household members, family members, or co-owned dogs. However, all qualifying scores earned prior to their starting judging are retained. Any licensed judge in attendance has a professional obligation to step up and become a judge of record in this instance.

Any replacement judge remains bound by these Guidelines and the Regulations for Agility Trials. Approved course designs should be transferred from the approved judge to the substitute judge, if possible, for their use. If they cannot be transferred, a Field Rep can assign any courses needed.

Event Committee cancellation of a judge: Clubs have the option of requesting that a judge cancel from an upcoming assignment with the following conditions:

- The cancellation request must be presented in writing from the club to all parties affected.
- All parties affected must agree on all parts of the cancellation agreement, including how to handle those courses already designed by the judge being cancelled.

- If you are the judge taking on additional classes and you wish to re-design or alter the already-approved courses, check with your reviewing Field Representative first (prior to accepting the cancellation request) if the cancellation is after the day courses for that trial were due.

Judge vs. Event Committee responsibilities: A judge's responsibilities and duties are primarily within the ring. The Event Committee primarily deals with issues outside the ring. As a judge of record, be careful not to overstep your authority. For example:

- If there is a complaint leading to a misconduct hearing, you are not involved unless you personally witnessed the incident.
- Should an incident occur, please write up your description of who and what occurred in the Comments section of your Judge's Post-Show web form report so that the details of the trial and the incident are in one document. Please do not send your write-up in a separate email.
- If you witness dogs wearing collars that are not allowed on the AKC show grounds, you should ask the Trial Committee to address it with the individual owners.
- If the rings are not running efficiently due to conflicts, you are required to discuss with the Trial Chairman and Trial Committee possibly switching the jump height order in the class (if it would help). The Trial Committee has the authority and final decision to switch the jump height order. However, the class order may not be switched from the published judging schedule. You are not allowed to start a class prior to its published start time. Any change to the jump height order should be carefully considered prior to implementing it due to the potential confusion among exhibitors. If any change is made, accommodation to the maximum extent feasible would be appropriate for confused exhibitors.
- The manner in which a club gives out its ribbons and awards is up to the club (after the judge has verified the accuracy of the scribe sheets), as long as it is within AKC policy. The club may ask the judge for his or her help, but it is the club's choice.
- It is the judge's responsibility to verify that the classes listed in the premium match the contract.

SECTION 4. Judging Disciplinary Policies

Unapproved courses: A judge that uses an unapproved course or fails to make required corrections to courses without just cause is subject to a reprimand. Depending on severity, this disciplinary action can range from one or more of the following: a verbal warning from the Agility Director that becomes a permanent part of the judge's file, full suspension, returned to

Novice/Open provisional status, attend judge's reeducation, required to return future courses 60 days in advance of trials, inactivation of judge's license, attend and pass a judge's seminar

Unsatisfactory observations: Any judge that has received three consecutive unsatisfactory supervisions or four out of five unsatisfactory supervisions at their current status level will immediately be returned to Novice/Open provisional status or be placed on inactive status and required to attend and pass a full judging seminar.

Regulations violation: Any judge that violates or fails to uphold the AKC's rules, regulations, guidelines, judge's blog and newsletters, policies and/or Code of Sportsmanship is subject to a reprimand. Depending on severity, this disciplinary action can range from one or more of the following: a verbal warning from the Agility Director that becomes a permanent part of the judge's file, full suspension, returned to Novice/Open provisional status, attend judge's reeducation, required to return future courses 60 days in advance of trials, inactivation of judge's license, attend and pass a judge's seminar.

Prejudicial conduct: Any judge that participates in any action that is prejudicial to the sport of agility or any other AKC event shall be subject to a reprimand. This disciplinary action can range from a verbal warning that becomes a permanent part of the judge's file, to full suspension and/or fine depending upon the severity of the offense.

SECTION 5. Late submission of courses

Submission of courses: All courses for fully approved judges will be due to their reviewing Field Rep a minimum of 45 days in advance of the first day of a set of trials (60 days for provisional judges). A judge may be required to submit courses earlier, and if required to do so must be notified in writing of this requirement (cc'd to the Director of Agility). The timely submission of courses (both the initial submissions and any resubmitted courses) is essential to the sport of agility and to the enjoyment of the dog and handler as well as providing a unique experience to both. It allows the judicious reciprocation of courses between the judge and reviewing Field Rep, especially in cases where there may be several exchanges required. The late submission of courses may result in courses that do not comply with regulations and guidelines and may also jeopardize the safety of the dog and/or handler on the course.

These minimums can be waived if there is a late/emergency change of venue or assignment. Field Reps will return all original courses a minimum of 10 days prior to the first day of a set of trials.

Course submission offense policy - Late submission of any or all course design(s) will result in the following:

1st offense: A verbal warning shall be given to the judge by the reviewing Field Rep. An email must be sent from the Field Rep to the Director of Agility and cc'd to the judge stating that the verbal reprimand was given.

2nd offense: A written warning letter or email shall be sent to the judge from the reviewing Field Rep and cc'd to the Director of Agility. For the period of one calendar year, the judge will be required to return courses at least 60 days prior to the first day of the start of each trial.

3rd offense: A written warning letter shall be sent by certified mail from the Director of Agility, which must be signed by the judge and returned within 30 calendar days. For a period of two calendar years, the judge will be required to return courses at least 60 days prior to the first day of the start of each trial. If this letter is not returned within this time frame, the judge will immediately be placed on suspension for a period of 6 months., after which they will be reinstated to the Excellent Master level at provisional status requiring their assignments to be approved by the Director of Agility. (The judge will be allowed to complete up to two months' worth of assignments before the suspension is invoked).

4th offense: The judge is immediately placed on suspension for a period of one year, after which they will be reinstated to the Open/ Novice level at provisional status, requiring their assignments to be approved by the Director of Agility. (The judge will be allowed to complete up to 2 months' worth of assignments before status is invoked.)

Once the judge successfully completes all the disciplinary actions and returns to full judging status, the following will apply for repeat offences:

1st offense: A written warning letter or email shall be sent to the judge from the reviewing Field Rep and cc'd to the Director of Agility.

2nd offense: A written warning letter shall be sent by certified mail from the Director of Agility which must be signed by the judge and returned within 30 calendar days. If this letter is not returned within this time frame, the judge will no longer be eligible to judge agility for the American Kennel Club.

3rd offense: The judge will no longer be eligible to judge agility for the American Kennel Club.

If the judge has no late course submission offenses for a period of two years after their first written warning, their late course submission status will be wiped clean of previous offenses and any further offenses will again start at the beginning.

During any suspension, a judge will be allowed to attend a re-education seminar to remain current with judging information.

SECTION 6. Submission of Courses for Review and Correction

In addition to the requirement of submitting courses 45 days in advance of the first day of a set of trials (60 days for provisional judges), there are requirements for returning R&R and/or any course changes. If a judge receives an R&R, the judge has 7 days after receipt of the R&R to resubmit corrections. A judge also has 7 days from receipt of reviewed courses (non-R&R) to resubmit any changes.

Corrections to submitted courses: Individual comments may appear on courses returned to course designers after review. Each abbreviation is usually followed by an explanation, and possibly a recommendation as to how to fix the problem. The following is a list of the most typical notations used:

MC – Must Change: A specific regulation or aspect of the guidelines has not been adhered to, and the course must be changed prior to the final draft. Not changing a “MC” on a course renders it unapproved and is basis for disciplinary action.

HR – Highly Recommend: While the course is not in violation of a regulation or the guidelines for course design, the course reviewer strongly believes there is a problem that should be addressed. Course designers should carefully consider the course reviewer’s comments and suggestions; however, the final decision to change or fix the issue identified is up to the course designer.

Course approvals: Your courses will be sent back to you with one of the following designations:

- **Approved or APP** – No comments requiring change, the courses are ready to go.
- **Approved as Noted or AAN** – Comments requiring change(s) usually minor in nature and easily understood. *If changes are made as suggested, the courses will be ready to go. If the course designer wishes to fix the problem in a **different** way, the course must be resubmitted for review, or be considered unapproved. Resubmitted courses are due within 7 days from the date returned to the judge by the reviewer.*
- **Revise and Resubmit or R&R** – Course has been noted as to the

reason it does not comply with the guidelines or regulations, and the course must be redrawn and resubmitted for review and approval, whether any suggestions have been made by your reviewer. Any revisions must be resubmitted within seven days from the date they were returned to you by the reviewer.

- **Redesigned or RED** – Reviewing Rep has redesigned a course that would otherwise have been an R&R. *If the course designer wishes to fix the problem in a **different** way, the course must be resubmitted for review, or be considered unapproved. Resubmitted courses are due within 7 days from the date returned to the judge by the reviewer.*

Course design deficiencies: Any judge that has consistently demonstrated the inability to design courses according to the requirements in the *Regulations for Agility Trials* and the *AKC Agility Judge's Guidelines* shall adhere to the following progression:

1st offense: A written warning letter or email shall be sent to the judge from the reviewing Field Rep cc'd to the Director of Agility. The judge may be required to provide a course checklist for all future courses. The checklist will be provided by their Field Representative. They may be required to complete on-line course(s), review material, special assignments and or videos specified by their Field Representative.

2nd offense: A written warning letter shall be sent by certified mail from the Director of Agility which must be signed by the judge and returned within 30 calendar days. The judge may be required to provide a course checklist for all future courses. The checklist will be provided by their Field Representative. They may be required to complete on-line course(s), review material, special assignments and or videos specified by their Field Representative. They may also be placed on Excellent/Master provisional status, accepting minimal assignments approved by the Director of Agility. If this letter is not returned within this time frame, the judge will immediately be placed on Novice/Open provisional status.

3rd offense: The judge shall immediately be placed on Novice/Open provisional status. Novice/Open provisional status will require the judge to contact the Agility Director to accept assignments. The judge will be required to submit future courses at least 60 days prior to the first day of a set of trials. The judge may be required to provide a course checklist for all future courses. The checklist will be provided by their Field Representative. They may be required to complete on-line course(s), review material, special assignments and or videos specified by their Field Representative.

Once the judge successfully completes all the disciplinary actions and returns to full judging status, the following will apply for repeat offences:

1st offense: A written warning letter or email shall be sent to the judge from the reviewing Field Rep and cc'd to the Director of Agility.

2nd offense: A written warning letter shall be sent by certified mail from the Director of Agility which must be signed by the judge and returned within 30 calendar days. If this letter is not returned within this time frame, the judge will no longer be eligible to judge agility for the American Kennel Club.

3rd offense: The judge will no longer be eligible to judge agility for the American Kennel Club.

If the judge has no course deficiencies for a period of two years after their first written warning, their course deficiency status will be wiped clean of previous offenses and any further offenses will again start at the beginning. During any suspension, a judge will be allowed to attend a re-education seminar to remain current with judging information.

AKC agility staff reserves the right to deny, with just cause, the privilege to become or remain an AKC agility judge.

SECTION 7. Certification

All judges are required to attend and meet all requirements of a re-education seminar at least once within a three-year period. It is the judge's responsibility to ensure that they engage in the re-education seminar and fulfill the current requirements prior to their anniversary date. Any judge who does not fulfill this requirement shall adhere to the following:

The judge shall be placed on inactive status as of the three-year anniversary of the date of their last attended re-education seminar. This status renders the judge unauthorized to judge any and all assignments from the third year anniversary date until such time as the requirements are met.

Once on inactive status, the judge can only be reinstated to fully-approved judging status by attending and fulfilling the requirements of a re-education seminar. Judges have one year from the date they were placed on inactive status to complete this requirement.

Once a judge has been on inactive status for more than one year, he/she will

be required to attend and pass all requirements of a full judging seminar in order to be restored to fully approved and active judging status.

AKC agility staff reserves the right to deny, with just cause, the privilege to become or remain an AKC agility judge.

Section 8. Handling Dog Aggression

Please refer to Chapter 1, Section 23 of the *Regulations for Agility Trials* for the policy on handling dog aggression. The following is a synopsis of this policy in an easy to follow table form.

All incidences of aggression should be described in the Judge's Report submitted to the Director of Agility.

		ACTION							
		Revised 7/22/2010							
		Dog Excused by Judge	Judge Completes Dog on Dog Attack (form AEDSQ3)	Dog Disqualified by Judge	Judge Completes Disqualification for Attacking (form AEDSQ1)	Event Committee Must Consider Disqualification of the Dog**	Event Committee Completes Dog Disqualified by Event Committee (form AEDSQ4)	Preliminary Investigation for Event Hearing Against Person May Be Held	Preliminary Investigation for Event Hearing Against Person Must Be Held
	INCIDENT								
1	Aggressive behavior in the ring toward a person or dog*	X						X	
2	Dog leaves the ring and threatens a dog or person and the Judge is able to see incident*	X						X	
3	Dog either runs out of the ring and attacks another dog or into the ring and attacks another dog*	X	X			X	X	X	
4	Dog attacks any person in the ring or while being measured by the Judge			X	X			X	
5	Dog attacks any person or dog outside of the ring					X	X	X	
6	Dog attacks any dog or person anywhere on grounds and there is a serious injury					X	X		X

* Two incidents of aggressive behavior will cause the dog's disqualification.

** Disqualification by the Event Committee requires three things to be true: 1) There was an attack; 2) There was an injury; 3) The Event Committee believes the dog is a hazard to people or dogs. -No member of the Event Committee need witness the attack. If the Event Committee becomes aware of an attack, they must consider disqualification.

TERMINOLOGY

Excusal: Recorded on scoresheet and in signed event catalog as "EXCUSED". Excusals are for lesser infractions and dogs get a second chance.

Disqualification by Judge: Recorded on scoresheet and in signed event catalog as "DISQUALIFIED". These are for significant infractions and dogs do not get a second chance.

Aggressive Behavior: This would include growling or threatening barking.

Attack: Any instance where the dog actually tried to grab someone or did grab them. Skin contact is not required.

CHAPTER 2

JUDGE'S DUTIES PRIOR TO THE TRIAL

SECTION 1. Communication

Communication with trial-holding club: Correspondence with the club prior to the trial will help ensure its success. Calls inquiring about availability for judges should be returned promptly. The judge should get both the Trial Secretary's and the Trial Chairman's phone numbers (cell phones and email addresses are also very helpful) to have at least two points of contact with the club.

Items requiring clarification prior to accepting assignments: Verifying these items is required prior to accepting an assignment from a club.

Dates and the trial location: This is so you can verify that you will not be in conflict with the regulations regarding other trials that you may have already committed to judge (200 miles within 30 days). If the distances are close, you or the club should request that the AKC verify the distance between trials based on the AKC's "in-house" program that calculates the distance between trials.

Judge's fees: Judge's fees should be discussed and agreed to prior to accepting the assignment.

Expenses: Determine what expenses the club is paying for, such as course copies, travel fees (expectations of whether the judge will arrive by car or plane), meal costs, etc.

Classes: Determine the class(es) the judge is being asked to judge.

Judging limits: A judge should discuss his or her own personal judging limits (i.e., the number of dogs they feel they can judge consistently in one day) with the club if the number is less than the limit imposed by the AKC.

Travel arrangements: Determine who is responsible for making travel arrangements to get the best rates. Whoever makes the arrangements, it is important to note that the judge is committed to the club to judge all classes he or she agreed to judge. A judge may not leave prior to completing the assignment, which includes verification of all scores in the official catalog. It is imperative that a sufficient amount of time be allowed between the expected finish of judging, completion of all paperwork, and the time when the judge must leave. The Trial Chair or Secretary can give usual entries and judging lengths to give you some information on which to base your transportation choices.

Reimbursement for out-of-pocket expenses: Discuss how quickly the judge will be reimbursed for out-of-pocket expenses. This is especially important

if the judge is arranging his or her own flights.

Judge's number: If you agree to accept the assignment, give the club your judge's number, as they will need it when they submit the judging panel for approval.

A written contract between the judge and the club is essential to clarify what each party expects. Items listed above should be in the contract. Additionally, a judge may wish to include other provisions in the contract such as food and beverage requirements or who picks up the expenses if the judge is unable to make the scheduled return flight, thus incurring another night of expenses.

Additional items a judge should inquire about prior to departing for the trial: Clarifying these items may help you head off problems before they can develop.

- How will the judge be transported from the airport to the hotel and then to the trial site? If a club member is picking the judge up, get the person's name, phone number, and cell phone number.
- If the club wants course copies for the exhibitors, who is to get them and is the club willing to pay for them? Full courses shall not be released to anyone for printing or course setting prior to the day of the show.
- What amount of ring help is expected?
- What is the check-in procedure the club is expecting to use to ensure that all dogs requiring measuring are measured? Confirm that the club has an approved measuring device and a level hard surface (such as an extra pause table) for you to use.
- Does the club want a copy of the contact placements for the first class of the day? Be sure to provide course builder copies in BMP or PDF format. **It is expressly forbidden for the judge to send to anyone the entire numbered course ahead of time.** The judge may send the locations of the contact obstacles with the rest of the equipment grouped together in quadrants (not laid out) and coordinates for other obstacles so the club can 'flag' the course, using the baseline setting method. Within 48 hours of the trial, the judge may give the club a builder's map with all of the obstacles in their locations **BUT WITHOUT NUMBERS, ENTRY/EXIT, OR SEND LINES**, so that the obstacles for the day's first course can be set the night before the trial. The judge may leave a copy of the next days' course(s) at the hotel's front desk any time after 12:00 midnight.
- Judges shall keep the clubs up to date as to any changes to their phone number, address, or email address, so that clubs may stay in touch with the judge they hired.

Items the judge must know prior to designing courses: These are items the judge must obtain from the club prior to designing the courses.

- The exact course dimensions and the side where the ring gate openings should be placed.
- The running surface.
- Hazards that would need to be designed around, such as areas of uneven ground, columns, posts, trees, rounded corners, and anything else that may be in the intended ring.
- A complete equipment list, including lengths and quantities of open tunnels, widths of jump bars, and number of winged vs. wingless jumps along with wing sizes.
- Combinations of weave poles that can be formed.
- Whether electronic timers will/will not be used and what, if any, limitations they may have. If a club is not using electronic timers, it is recommended that they note this in their premium list.

If you have accepted an assignment and are having trouble obtaining the information listed above in a timely manner, please call your course-reviewing Field Representative for help. Alternately, you could email the club with your request for information and copy your Field Representative.

Communication with the AKC: Communication between an AKC agility judge and the AKC office and field staff is important to keep judges abreast of changes to the regulations, recent clarifications of the regulations, and any policy changes that may come about. It is essential that you contact your Field Representative in charge of course review and the agility office staff at the AKC offices if any of your contact information changes, such as name, phone number, fax number, email address, and postal address.

SECTION 2. What to Bring on Your Assignment

The following is a list of things that you should bring on your judging assignment:

- Course copies for posting (do not include judge's path on these copies)
- Course copies for course builders with coordinates (minimum of 3 copies)
- Course copies for the club (complete copies shall not be given out until the day of the trial)
- A copy of the most current editions of the following:
 - Regulations for Agility Trials
 - AKC Agility Judge's Guidelines
 - Rules Applying to Dog Shows

- Dealing with Misconduct
- Current Judge’s Newsletters and blog notes
- Standard course time (SCT) worksheets
- Copy of your posted briefing (it is optional to post your briefing)
- Calculator for figuring course yardages and times
- Whistle
- Stop watch (as a back-up)
- Tape measure

SECTION 3. Prior to Arriving on Site

Regulations review: A judge has many demands on his or her time at the trial so the better prepared a judge is prior to the morning of the trial, the quicker the trial goes, and the more professional a judge appears. Therefore, it is important that you re-read the Regulations, Guidelines, and judge’s blog within a few days before the trial to refresh yourself.

Review arrangements: You may want to contact the club a day or two prior to leaving for the trial to ensure that all preparations have been made and that nothing has changed in regards to your transport and lodging.

CHAPTER 3

COURSE DESIGN

In addition to the requirements listed in the current edition of the *Regulations for Agility Trials*, course designs shall comply with provisions of this chapter and any future interpretations published by the AKC Agility Department.

Refer to Appendix for diagrams listed in this chapter.

SECTION 1. Course Design Responsibility

Course design responsibility: The AKC encourages variety in its course designs, thereby ensuring agility exhibitors a truly unique experience each time they enter the ring. The AKC, through its regulations and guidelines, defines the limits within which you may design the courses for an agility trial. The course review process may provide additional information that you will find helpful in producing courses that contain appropriate challenges, and are fun yet challenging to run. However, you are the author of your courses and are ultimately responsible for their uniqueness and content.

Because the AKC encourages variety in its course design, courses that have been used previously must either be mirrored or substantially changed before they are again submitted for review. Any course(s) previously reviewed, mirrored or otherwise, must be noted when submitting the course(s) for review. Furthermore, the mirrored courses cannot be used during the same trial weekend or cluster of trials. An original course may only be mirrored once; a mirrored course may not be re-used again without substantial changes. Mirroring must not be done in a predictable fashion.

Review process: The complete set of course designs for an assignment must be submitted to the AKC Field Representative a minimum of 45 days for fully approved judges and a minimum of 60 days for provisional judges prior to the start of the trial, unless prior arrangements have been made with and approved by the reviewer.

All course designs shall have the following on each course:

- Required obstacles for the class level with obstacles numbered sequentially
- Start and finish lines indicated in FAST
- Timer location
- Judge's path shown accurately
- Judge's name (author of the course)
- Class type and level
- Actual and complete name of the club, not just their acronym

- Actual date the course is to be used

The judge must provide the following information on the cover sheet, if required, or in an email message submitted with a set of courses for review to ensure an informed course review can be completed:

- Running surface
- Actual ring dimensions
- Any obstructions in the course area including their dimensions
- Indication of whether the trial is indoors, outdoors, or outdoors under cover
- Return e-mail address and a phone number where the judge can be reached for questions
- If e-timing will not be used

SECTION 2. The Mechanics of Designing Courses

Getting started: Once you have obtained the necessary details about the available obstacles and ring conditions (as listed in Chapter 2 of these Guidelines), you can begin preparing course plans. All course plans shall be created using a computer program that ensures that all courses are drawn to scale.

Designing with a computer: Computer programs allow you to set the ring dimensions and locate any obstructions. The computer will keep everything within the drawing in scale but will not necessarily print out the course at a 1" = 10' scale (this is important for those setting courses by the baseline method). Computer programs will typically give you options for different sized equipment and a number of open tunnel shapes to choose from. Be accurate as to the placement of obstacles on your design since it is very important that the Field Representatives see exactly what you intend to set on the course. All courses must be submitted using the latest or announced approved version of Clean Run Course Designer.

Class levels, where to start: A set of courses that is nested has most obstacles in the same area of the course, if not in the same position (especially the contact obstacles), to make course changes quick and the ring crew more efficient. **However**, trying to achieve the ultimate nested set of courses is not the most important thing in course design. It is better to move a few things, even contacts if necessary, to ensure that dogs have unique and appropriate levels of challenge, approach angles and fun courses to run. To produce nested courses, some judges like to start with the Excellent/Master class and modify for Open and Novice, reducing the equipment, challenges, and angles. Other judges like to start with the Open class and modify up and down from there.

Required obstacles: In addition to the regulations regarding required, allowed, and not-permitted obstacles (listed in each class's chapter in *Regulations for Agility Trials*), these are additional suggestions pertaining to required obstacles:

- It is permissible for the course to have a seesaw or an A-frame immediately following the table, subject to the ability to be correctly judged. Table to dog walk is not allowed.
- Given enough course area, it is generally recommended that jumps be winged rather than non-winged. Each type of jump requires a different skill in its performance. Non-winged jumps work best where space is limited or there are many obstacles in close proximity to one another; however, you must keep in mind that there must be a minimum of 50% winged jumps used on any given course. This count is to include actual jumps, not how many times they are used.
- Pause tables should be placed in the middle third of a standard course with a flat approach to the flow of the dog, and must not be placed anywhere on the course that does not allow the judge to be in position to properly judge any other obstacle.
- Refer to the required obstacle charts at the end of the class descriptions in the *Regulations for Agility Trials*. Course designs must comply with the list of which obstacles are required, allowed, and not permitted for each class and with the number of times obstacles may be performed in each class level. Note that options for the course designer exist regarding spread jumps in some classes. These are designated by an asterisk (*).
- Only a panel, bar or one-bar jump, double, ascending double, wall, tire or tunnel is permitted to be used as the first obstacle. Only a panel, bar or one-bar jump, double, ascending double, wall, triple jump, tire or tunnel is permitted to be used as the last obstacle.
- If the double, ascending double, or wall is used as the first obstacle, it must be placed a minimum of 21 feet from barrier per dog's path.
- If wind conditions merit, the panel jump may be replaced with a bar jump.
- If a judge's course design includes the challenge of a backside approach (including a bidirectional jump in T2B or Premier), then it must be to a winged jump.
- Dummy obstacles are allowed on a course at the discretion of the course designer. Dummy obstacles are not performed in the normal sequence of the course, but are placed on the course (at the appropriate jump height) to provide an option or handler restriction, which increases the challenge level. A well-designed course may not need any dummy obstacles, and routine and/or overuse of dummy obstacles should be avoided. However, if they are used, no more than two dummy obstacles shall be placed on any course and no more than one on Novice courses.

- Dummy obstacles allowed:
 - a) Panel jump, one-bar jumps, and bar jumps.
 - b) Dummy open tunnels are allowed but not encouraged, and should be placed at the maximum distance allowed.

Required quantity of obstacles per class level: The required quantity of obstacles per class level is as listed in the *Regulations for Agility Trials* and must be strictly adhered to.

Obstacle spacing: Obstacle spacing is critical to good course design. If spacing is too tight, the course can become choppy and dogs will have a hard time making course time. If spacing is too wide open, it will cause the wrong course options to be muted due to distance. Also, a course that is really wide open may be such that slow handlers with fast dogs are greatly disadvantaged, for the dog will cover ground much faster than the handler and will be further from the handler when a wrong course option is encountered, or it may consistently cause refusals since there will be little in front of the dog to keep its focus.

For course review purposes, obstacle spacing is measured along the expected path of a dog jumping at the 20" height. Obstacle spacing minimums and maximums are spelled out in the *Regulations for Agility Trials* and shall be adhered to.

In addition to the above requirements, judges should be aware of the following when determining the spacing of obstacles on a course:

- 15 feet is the minimum spacing between two sequentially placed obstacles, with a minimum of 18 feet to jump obstacles (20 feet or more recommended) and a minimum of 21 feet to any spread jump (21 feet or more recommended after a spread jump).
- Spacing in excess of 25 feet should generally be used when there is a reason for it. This includes the following:
 - a) Crossing patterns with 5 or more obstacles forming a box, which pushes obstacles further apart to keep the area on the course from being too congested.
 - b) Wrap around jumps and pull-throughs.
 - c) Layered jumps in some conditions.
- Uniform spacing promotes a rhythm to the performance of the obstacles and is less challenging than irregular or variable spacing that requires more skill, as the dog will need to adjust its stride length and speed to properly negotiate the obstacles.
- When setting a 270-degree jump sequence, judges must allow enough distance for the dog to make the turn without being right on top of an

off-course obstacle. A minimum of 7 feet is required from the run-out line of the second obstacle in the 270-degree turn to an off-course obstacle. (See diagram 322 for illustration)

- A 15' minimum shall be required to any direct wrong-course possibility and to any run-out line (ROL) of the next correct obstacle. Only off-course options that are in direct path of the dog as they complete the previous obstacle must be a minimum of 15 feet in distance. Off-course obstacles that the dog would have to adjust their path to navigate may be less than 15 feet in distance, depending upon whether the dog can navigate the approach angle safely.

Approach angles: Approach angles shall not exceed those listed in *Regulations for Agility Trials*, which indicates not only the maximum angle allowed for each class level, but also the maximum number of times a dog can be expected to perform these angles. Note that a course over-burdened with an excessive number of big angles or sharp turns is de-motivating for a dog and the course will lack flow, making it difficult for dogs to stride out and make course time.

The approach angle is calculated on the basis of the **expected path** of a dog jumping 20", not the pure geometric angle formed by the obstacles as they lay on the course plan. Approach angles depend greatly on where dogs are coming from, where they are going to, and the speed they are traveling when they need to make the turn. (See diagram 323)

Approaches to the triple at all class levels shall be as straight as possible, including as wrong course options. There must be enough room to square up to the spread jumps if the dog has to execute a turn prior to the spreads.

The approach angle to the tire, double, ascending double, and wall/viaduct should be straight to very mild at all class levels, including as wrong course options. This is due to the radically shrinking aperture of the tire as it is angled away from the dog's approach path (the more acute the angle, the smaller the opening that is presented to the dog), and the increasing distance to clear a spread at an angle. If these obstacles are used more than once on the course, each approach must adhere to these requirements (see diagram 3.2.4).

At the Novice level, **all** obstacle approaches should be straight to mildly-angled. Degrees of a turn should generally not be more than 90 to 135; however, a maximum of one 180-degree turn will be allowed.

For all classes – A turn from the exit of a tunnel placed under or adjacent to the A-frame, to the ascent of the A-frame is not allowed. (See diagram

Placing of timers, scribes, and obstacle numbers:

Timers and scribes: Place them where they can be together and do not have to move to see you. Place in a location so that they can see the openings for the entrance of the start obstacle and the exit of the finish obstacle without moving, and where they will not be a visual or physical impediment on the course.

Obstacle numbers: Should be placed on the course design next to the approach side of the obstacle where you wish the ring steward to place the number when setting the course. Obstacle numbers should be placed so they are readable for someone running the course, but primarily they shall be placed where they will not be in the way of the dog and handler. When two obstacles are in close proximity to each other, the obstacle numbers should be placed so as not to cause exhibitor confusion when reading course maps or walking the course. The number for the weave poles may be removed after course walkthroughs if it has the potential of being in the handler's way.

SECTION 3. Judge's Position in Course Design

One of the most important aspects in course design is to develop a course that allows the judge to be where needed to judge the dog fairly and equitably. The course design should allow the judge to conserve his or her movements so as to not distract the dog, get in the dog's or handler's way, or become tired after potentially judging hundreds of dogs on the course. The judge and the judge's movements are not to be the focus of the performance in the ring.

Places a judge must be on the course: The following are the maximum distances a judge can be from the dog being judged and the required locations a judge shall be when judging specific obstacles. The course design shall allow the judge to comply with the following (See diagram 3.3.1 for examples):

- *A-frame, seesaw* – Judge all approaches for refusals, and all judged contact zones from a distance no greater than 20 feet. Also be in position to see the contacts when they are an off-course possibility.
- *Dog walk* – Judge the approach from no further down the dog walk than even with the top of the down ramp, and judge the down contact zone from a distance no greater than 20 feet and be in position to see either ramp when it is an off-course possibility
- *Tunnels* – The judge shall be able to see all entry and exit openings, including when they present themselves as an off-course possibility, and including when they are the start or finish of a course

- *Tire* – The judge must be able to see the dog go through the opening, not just jump, as some dogs go between the tire and frame, thus judging the tire on its run-out line is not a viable position. The judge must be able to see if the tire splits/breaks.
- *Table* – The judge must be within 20 feet of the table at some point during the five-second count, with the handler **not** between the judge and the dog, to judge whether the dog is on the table as well as possible contact between the handler and the dog or table.
- *Weave poles* – The judge must be in place to see the dog’s entry and performance of each weave pole and any handler/dog contact.
- *Broad jump* – The judge must be within 30 feet of the broad jump during its performance to see if a board moves or is stepped on, and must not be directly in front of nor directly behind the broad jump.
- *Bar jumps, including spreads* – The judge must be able to see the bars of all jumps as the dog is jumping them to determine if the dog has displaced the top bar(s). Large solid wings, especially on the triple and double bar jumps, may force the judge to alter the judging path in order to see all bars.
- *Wall jump* – The judge must be within 30 feet of the wall/viaduct jump to judge whether a dog has visibly displaced or moved any of the “tops.” The judge’s path must be to the front or back of the jump to see each “top.”
- Obstacles may not be in between the judging path and the judged contact zones of any contact obstacle where the judge may need to be able to get “in” to be in proper position. Although 20 feet is the stated maximum, always keep in mind when designing courses that individual runs may require you to move in closer. (See diagram 3.3.2).

Judge’s movement in course design: Courses should allow for judges to move efficiently into place without the judge racing the dog and handler to get into position. Judging paths should not cross in front of the dog and handler unless there is plenty of time to do so without interfering with the dog or handler. The judge’s path shall not pass over, under, or through any obstacle. The judge’s path should be as consistent as possible for all dogs, and the judge’s position should not block possible off-course options, thus reducing the challenges on the course. On all Jumpers with Weaves courses, the judge shall be **REQUIRED** to move in order to properly see all run-out lines, tunnel entrances and exits, and weave pole performance and/or handler/dog contact.

SECTION 4. Course Safety

Obstacle proximity to ring barriers, walls, and other obstacles: Safety

should always be first and foremost in the judge's mind; however, the sport of agility, with its variety of obstacles, quick decisions, varied weather conditions, and running surfaces has some inherent risk to it. The judge can mitigate some of the safety concerns in the course design phase by avoiding the placement of obstacles in close proximity to each other or to the ring barrier.

Not every dog runs the expected path, and some dogs can be somewhat out of control; consequently, courses should be designed with this type of dog in mind. Look at what could happen vs. what should happen. Distance may cure many problems when it comes to safety. A greater distance to the ring barrier or between obstacles that are side by side may well enable the less-than-focused dog to recover prior to getting itself into trouble. The following are minimum standards that must be maintained to provide as safe a course as possible:

- For placement of all types of jumps and contacts in relation to a ring barrier or wall, provide a minimum of 6 feet of clear space if course flow is parallel with the ring barrier or wall, and a minimum of 15 feet if the dog is jumping or running into the ring barrier or wall (see diagrams 3.4.1 and 3.4.2). This requirement also applies to possible off-course jumps and dummy jumps.
- Tables shall not be placed any closer than 6 feet to a ring barrier, wall, obstruction, or other obstacle as measured to the closest part of the table.
- Obstacles placed in close proximity to each other shall be set such that a dog has no chance of landing on one while jumping the other or of falling from a contact obstacle onto something sharp below.
- Any part of obstacles (other than tunnels for the dog walk and A-frame), must be the minimum distance listed below when placed next to a contact obstacle:
 - Dog walk: 4 feet minimum next to the yellow zone (up and down ramp); 6 feet minimum, if next to any other part of the dog walk
 - A-frame: 8 feet minimum
 - Seesaw: 4 feet minimum next to the entrance; 8 feet minimum next to the exit, 10 feet recommended
- Jumps that touch each other must be winged

Other safety issues that must be accounted for in the course design:

- Sufficient room to start and finish inside the ring is critical for the safety of the dog and the prevention of dog aggression. Courses must be designed to allow for a minimum of 15 feet from the ring barrier to the first obstacle and 20 feet after the last obstacle to the ring barrier, measured along dog's path (See diagram 3.4.3). Also remember that if

the double, ascending double, or wall/viaduct is used as the first obstacle, there must be a minimum of 21 feet from the ring barrier to the obstacle.

- The upside of the seesaw can present a hazard to handlers if it is placed contrary to the course flow, and the handler's expected running path brings them in close proximity to it. Oftentimes, the handler's attention is diverted from their running path, for they are looking at the dog and may not see the elevated plank (see diagram 3.4.5).
- Columns, posts, and things that stick up out of the ground can cause safety concerns for both handlers and dogs. Handlers run into them for the same reasons as described above. Dogs run into them if the previous obstacle's performance does not allow them enough time to physically recover to steer clear of the danger. Placing wings of jumps and tunnels directly adjacent to columns (engaging them) will mitigate their presence (see diagram 3.4.6).
- Turns off spread jumps should be minimized, especially when the running surface is mats on concrete, or has the potential to be slippery.
- The expected approach to the table shall be to a flat side of the table. This prevents dogs from approaching the corner at speed. This is also a judging issue, for you need a backside line from which to call run-outs (see diagram 3.4.7).
- When a dog's expected jumping and landing path sends the dog directly at an obstacle, barrier, or obstruction (including the end of a wing or the jump standard on a wingless jump), a minimum of 15 feet is required. However, a variety of factors should be considered such as speed coming into the area, running surface and visibility. Fifteen feet may be sufficient, but based on the sequence and conditions, more may be necessary.
- With e-timing, the location of the timer eyes must be considered when the start or finish obstacle is taken more than once. Avoid designs where the timer eye stanchion could be an obstruction (see diagram 3.4.8).

SECTION 5. Obstacle Placement in Course Design That Can Cause Performance Concerns

The placement of obstacles in the design process can cause performance problems on the agility course. The following should be avoided:

- Placing the weave poles too close to a wall or ring barrier can cause visual problems for some dogs and some dogs need more space to feel comfortable weaving. The minimum placement of weaves along the barrier is 8 feet. If the weaves are placed perpendicular to the barrier or wall, the minimum entry is 8' to 10', however, more is recommended (see

diagram 35.1).

- Placing obstacles in close proximity to each other can cause an unfair advantage to some handlers. All obstacles shall be either greater than 4 feet apart (to their closest points) or closer than 12 inches. Either everyone gets between the two obstacles or no one should be able to get through (see diagram 35.2).
- Obstacles that require a straight approach should not have their entry angled towards a wall or ring barrier if placed in close proximity to a wall or ring barrier. Dogs do not like to work tight to walls, and placing obstacles too close to a wall will prevent them from having a straight approach to the obstacle.
- Tunnels in close proximity to barriers must leave a minimum space of 2 feet between the closest part of the tunnel and the barrier.

SECTION 6. Challenges Defined

Course designs and the challenges presented in them progress in difficulty from Novice to Open to Excellent/Master to Premier. The number of challenges shall increase, as listed in Section 7, and the types of challenges should increase in difficulty as well.

The best way to create challenges on a course design is to provide a course path with plenty of crossing patterns, which create options for dogs and side-switch opportunities for handlers. This keeps the course relatively smooth and flowing while providing challenges along the way. Handler restrictions that cause a handler to work away from their dog as well as options with discriminations, which are actually just more difficult options, can be added to the higher levels to provide a variety of challenges.

Options, restrictions and side-switches defined

• Side-switches

A side-switch is a place where the course makes an “S” curve, requiring the handler to switch from handling the dog off one side of his or her body to the other side. A handler who opts not to switch sides is forced to run around the outside of the obstacles and must run faster than the dog to keep up. The simplest side-switch to negotiate is one in which there are no options to confuse or lure the dog while the handler is making the side-switch. (See diagram 3.6.1).

• Options

An option is a point on the course where the dog has a choice of which obstacles to take (see diagram 3.6.2). Typically, options exist at crossing

patterns. Fifteen feet is the required minimum distance to a direct off-course option (i.e., an option where the wrong obstacle is placed directly in the dog's expected path of travel). An obstacle must be sightable, accessible, and desirable (SAD) to be counted as an option. Off-course obstacles that are 21 feet or less from the previous obstacle, within the dog's field of vision (90 degrees) based upon its path, and SAD, shall be considered an option. Obstacles that are in the direct line of sight (45 degrees) can be up to 23 feet from the previous obstacle. The exception to the distance requirement is a tunnel placed next to the contact zone of a dog walk or A-frame when the contact obstacle is the next correct obstacle. In this case, the tunnel will count as an option IF the entrance is even with any part of the contact zone AND no more than four feet away (see diagram 3.6.3).

Proximity options are obstacles that are SAD and the entrance is within 5 feet of the expected dog path. In certain cases, the proximity limit could be extended to 10 feet if the option is the most obvious obstacle, depending on the expected speed of the dog and/or the placement and relative visibility of the correct obstacle.

Weave poles may be counted as a challenge option only if the potential entry is within the distance requirement and the dog's path is on the approach side (see diagram 3.6.4).

Options become more difficult based on:

- a) The proximity of the two options to each other.
- b) The speed of the dog going into the area where the option occurs based upon his expected path.
- c) The distance the handler is expected to be away from the dog when the dog must make the decision as to which obstacle is the correct one.
- d) How visible and enticing the wrong course obstacle may be compared with the correct one. Some dogs prefer one obstacle over another, but some obstacles such as tunnels and A-frames are highly enticing, as dogs have a tendency to accelerate towards them.

Novice requirements for options:

- a) Novice dogs shall be given the obvious or logical opening to tunnels if there is a choice, based upon the dog's expected path.
- b) Approaches to two obstacles shall not be adjacent or in close proximity to each other. For example, a classic tunnel-contact option would not be allowed in the Novice class. However, a 180-degree turn from the exit of a contact into a tunnel will be allowed as long as the tunnel does not restrict the handler's ability to work close to the obstacle and the dog.

• **Handler restrictions**

Handler restrictions, which require the handler to deviate from the ideal handling path, shall be counted as a challenge when determining the challenge level for a course (see diagram 3.6.5 for examples). To be counted as a handler restriction, a tunnel placed under the dog walk or A-frame must come out at least six feet, so that the handler has at least six feet of lateral distance from the contact obstacle. When designing a course, a judge must be careful not to overload a course with too many handler restrictions, and when placing obstacles to create a handler restriction, a judge must be careful not to create a safety issue due to the proximity of the two obstacles. Any handler restriction used may not restrict the judge from being in proper position to judge any obstacle.

Novice requirements for handler restrictions:

Handler restrictions are allowed in the Novice class; however, they must be placed carefully and should be simple in nature. A handler restriction in the Novice class should be used mainly for course flow and to maximize the course area in tight ring conditions, not for testing whether a dog can work apart from the handler. An example of an appropriate handler restriction in the Novice class would be a tunnel placed under the A-frame or dog walk to get the dog and handler to another part of the course area. The tunnel must be placed such that the handler is able to work tight to the contact obstacle from the logical side of the contact obstacle (i.e., the side you would expect the majority of handlers to normally choose).

Multiple challenges at the same point on the course

There may be places on the course where there are two types of challenges happening at the same time, such as a handler restriction with an option. Where multiple challenges occur at the same time, they are counted as one challenge when determining the total challenge level of the course. However, when they occur at separate times but between the same two obstacles, they may be counted individually (see diagram 3.6.6).

Elements that may occur on a course, but are not counted towards the challenge level of the course

- Angled approaches to obstacles can be used at the judge's discretion for the desired effect, as long as they do not exceed maximum angles listed in the Regulations; however, such angled approaches are not considered a challenge and should be analyzed for safety.
- Right side or left side approaches can be used to any specific

obstacle, such as the weave poles, but do not increase the challenge level.

SECTION 7. Challenge and Side-Switch Requirements per Class Level

Minimum numbers per class level are listed below:

- All *Novice* classes: A minimum of 2 and a maximum of 5 separate challenges (options/restrictions) **and** a minimum of 2 separate side-switches are required.
- All *Open* classes: A minimum of 6 and a maximum of 8 separate challenges (options/restrictions) **and** a minimum of 3 separate side-switches are required.
- All *Exc/Master* classes: A minimum of 9 separate challenges (options/restrictions) **and** a minimum of 3 separate side-switches are required.

<i>Level</i>	<i>Challenges</i>	<i>Side-Switches</i>
Novice	Min 2, Max 5	2
Open	Min 6, Max 8	3
Exc/Master	Min 9	3

Side-switches:

- Side-switches are not counted as options/restrictions at any level.
- Side-switches at the table do not count toward the side-switch requirement at any level.
- In evaluating the number of side-switches and options/restrictions, Excellent/Master level handlers are assumed to have a lead-out at the start line to the second obstacle and at the table to the next correct obstacle, and Open handlers are assumed to have a lead-out halfway to the second obstacle and halfway from the table to the next obstacle; thus many options may be negated at these positions.
- When an option and side-switch happen at the same location, they will be counted separately for the purpose of conforming to the minimum requirements.

SECTION 8. Changes to Submitted Courses

Courses shall be set as close as possible to the approved course map. If circumstances such as course conditions, hazards, or insufficient equipment necessitate a change to these courses, such that you question yourself and/or the average competitor would say, “This course is different from the map” then attempt to contact an Agility Field Representative to aid you in any change(s) necessary and for field approval of said change(s). If no Field Representative is available, use your best judgment with the following in mind:

1. Modify first and foremost for safety. Respond to all unsafe conditions.
This does not include performance or training issues.
2. Maintain the required obstacles and the required quantity of obstacles per class level.
3. Make sure the change is still judgeable.
4. Maintain the challenge level to the maximum extent feasible.
5. Submit all course changes with your judge’s report to the Director of Agility. Failure to do so constitutes usage of unapproved courses and is grounds for disciplinary action.

CHAPTER 4

PREPARING TO JUDGE – DAY OF TRIAL

SECTION 1. Upon Arriving at the Site

Avoiding conflicts: Judges should be personable and friendly to club members, workers, and exhibitors while at the trial. However, as the judge you must avoid spending too much time with any one exhibitor or group of exhibitors, so that your judgment or impartiality in the ring cannot be questioned. Prior to judging a class, judges shall not review a catalog to see who is, or who is not, competing at a trial. Discussions with exhibitors should be light and friendly and shall not include any handling advice, training ideas, or insight as to what you were thinking when you were designing the course for that day.

Time sensitive issues that require the judge’s attention: The judge should arrive at the site at least one hour prior to the scheduled start of judging for the first class, preferably earlier. Arriving earlier is especially important if the club is new, there is a large entry or number of dogs to be measured, or the club or show site is unfamiliar to the judge. The judge should introduce himself or herself to the trial secretary and chairman and, if provisional, to the Agility Field Representative sent to observe. The judge should proceed to check the following before he or she gets too busy with exhibitors arriving:

- Review of ring – You must check ring dimensions with the calibrated measuring wheel to verify usable square footage, any obstructions and where the ring openings are located to make sure the courses will work efficiently, including any ring gating that may infringe upon the course area. Also, go over the running surface to find any areas that may require attention or repair. Any deficiencies in the running surface or ring conditions should immediately be brought to the attention of the trial chairman, trial committee or chief course builder so that they may be corrected. If the deficiencies cannot be corrected, the judge will note this on the AKC marked catalog and the Judge’s Report to the Director of Agility. The judge should then proceed to judge the class under the deficient conditions. In extreme cases when the deficiencies, in the opinion of the judge, are of such major proportion that it is possible that they may affect the dog’s performance or safety, the judge must brief exhibitors as to the specific deficient conditions. It is then the handler’s decision whether to compete under such conditions.
- Course builder copies – Give the course builders the course copies (for that day only) from which they can build the courses. Make sure they know which course is first and they build it in the proper ring.
- Posted courses – Give the secretary or table steward copies for posting

of all the courses you will be judging that day. If you are giving out course copies, ensure that at least one copy of each course is posted for public viewing. The posted course copies shall be posted a minimum of 30 minutes prior to the scheduled start of judging. All courses for that day may be posted at the same time.

- Club course copies – The club must be given course copies to keep.
- Check-in process – Discuss with the club the procedure to ensure that all dogs that do not have a permanent jump height card, at least one yellow form, or a valid temporary form are measured prior to running in the ring. This is best done very early, since check-in is often left to someone who does not fully understand that the check-in process is tied very tightly to the measuring process and ensures that dogs jump in the proper height class. Prior to measuring any dog that is on the measuring list, ask the handler if they have a valid card or form, as these dogs will not need to be measured by the judge of record.
- Equipment inspection – You are required to evaluate the equipment to ensure that it meets the specifications in the *Regulations for Agility Trials*. Make sure that the equipment is safe and in good repair. Do not trust someone's word as to whether the equipment is in compliance. Things happen over time or upon transport, and the equipment must be checked by the judge of record prior to running dogs. It is best to do this either the night before, if possible, or early in the morning. A summary of things to inspect are as follows:

Measuring wheel:	Check the wheel daily against a measuring tape on the ground to ensure its measurement is correct each day.
Contacts:	Width, height, length of contact zones, sturdiness, and surface is not too slick or abrasive. Ensure that there is a mark on chains to easily change A-frame height for the 4" and 8" dogs.
Seesaw:	Pivots properly using a 3lb weight 12" from end of board to calibrate drop rate within 3 seconds or less, and then returns to position. The club is required to have materials on hand for altering the drop if needed. This test must be conducted each day.
Jumps:	Displaceable, heights, spread width.
Wings:	Measure from a bar jump's upright edge where the cups exist (but the measurement does not include the cup itself) to the outer edge of the wing for correct width, including the uprights.
Tire:	Sufficient opening, sturdy frame that will not tip over, and has the ability to be weighted or staked.

Tire height markings should match the jump height, so that the ring crew will not have to be aware of the “one jump height lower” rule. The break-away tire must be calibrated at the beginning of each day before use to break between 16 and 20 pounds of pressure.

- Tunnels: Sufficient opening, holders are adequate and safe, no exposed wires. Ensure that the tunnel is fully extended, and not “squished” to accommodate a shorter length. Ensure that tunnels have 4” rib spacing.
- Pause table: Sturdy at its highest height, surface is not too slick or abrasive.
- Weave poles: Meets the dimension and construction specifications in the Regulations.
- Broad jump: Meets the height and width dimensions listed in the Regulations.
- Panel jump: Top panel is 4" wide for all jump heights.
- Wall: Width and height of boards, base, and “tops.”

Equipment specifications for electronic timers:

- The electronic timer system must be capable of operating in bright sunlight as well as rain, snow, fog, or dust particles.
- The electronic transmitters and receiver supports must be constructed so that they do not inhibit the handler’s or dog’s path. The supports may not be taller than 46”. The base that supports the transmitter and receiver may not be wider than 24” and the support must be constructed so that the upright and the beam can be no more than 4” from the obstacle. It is recommended that the material and color of the upright be similar to those materials normally used in the construction of agility equipment.
- The timers must have re-settable eyes in the event that an eye is tripped prematurely or accidentally, and in the event that a start or finish obstacle is to be used more than once on a course. The timers must have a manual override option allowing time to continue.
- The timers must have the ability to be connected to an external display.
- The timers must be capable of recording individual times to the nearest 100th of a second.
- The width of the interface on the beam is to be expandable to accommodate 4 to 5 foot jump bars and tunnels.

Maintaining required equipment for the class level:

Occasionally you will encounter equipment that is inadequate. It is important to fix, modify, or otherwise construct a solution that is safe and reasonably within the obstacle specifications in the Regulations so that the show can go

on. Do not use equipment that cannot be made safe. Every attempt should be made to modify the equipment so it can be brought into reasonable compliance, especially with regards to safety. You should make it clear to the hosting club and exhibitors that the AKC reserves the right to disallow scores and discipline the club if mandatory equipment cannot be used. Often an exhibitor or vendor has equipment with them or close by that can be borrowed, thus avoiding the problem for the day. If the class must be run without mandatory pieces of equipment, the judge must attempt to contact an AKC Rep or the Director of Agility prior to the running of the class. They also must file a report with the AKC office and the AKC Director of Agility.

Solutions to equipment problems:

- Dog walks that have too much flex in the ramps can be stiffened by propping boards or PVC poles under each board.
- Seesaws that don't tip properly, or that don't return after tipping, can be modified by adding weight to the underside of the board.
- If wind conditions merit, the panel jump may be replaced with a bar jump.
- Clubs utilizing electronic timers must be prepared to use manual hand timing if the electronic timers cease functioning correctly or become unavailable.

A little ingenuity and a lot of duct tape will solve many problems.

SECTION 2. Measuring of Dogs

Judge's responsibilities: If an AKC Volunteer Measuring Official (VMO) or Agility Field Representative is not present, the judge of record must measure all dogs that do not have a permanent card, at least a first-measurement yellow form or a valid temporary height card form with them. If a VMO or Field Representative is present, then all dogs must be measured by the VMO or Rep. If there are multiple VMOs measuring during the same trial weekend, an exhibitor whose dog is in need of a jump height card measurement is only required to obtain ONE measurement during the trial weekend. Although you may encourage additional measurements be obtained that weekend, there is no requirement to do so.

Handlers may challenge their own dog's jump height. A dog must continue to compete at the "original" jump height until the final challenge measurement (either the second or, in the case of a tiebreaker, the third) indicates a new jump height. The new jump height becomes effective immediately. The challenge process can only be done once while the dog is under 2 years old and once while the dog is over 2 years old.

Dogs do not have to be measured when the dog has **any** yellow slip where the measurement was done after the dog turned 2 years of age.

The purpose of measuring is to ensure that dogs are not entered in a jump height lower than what they are allowed to jump and that preferred dogs are also not entered in a height higher than they are allowed to jump. An official measuring device is to be supplied by the host club. Be sure to ask the competitor if they have a permanent card or a valid yellow form in their possession.

Measuring shall take place on a smooth level surface such as a pause table. Calibrate the measuring device before you begin measuring and re-check it EVERY TIME you return to do any further measuring. In general, greet the dog you are about to measure before attempting the measurement. Crouch low or squat down, but do not lean over the dog. Dogs should be standing squarely, not stretched out, looking straight ahead with the head in a normal position, not down or held down. Some dogs may hunch up from cold or tension, which can make them measure taller, so, if possible, it is advisable to let a dog become relaxed prior to placing the arm of the measuring device. Measure the dog at the peak of its withers, which is where the tops of the two shoulder blades come together, just below the neck.

If a dog is measured up into a higher jump height division, the move must be recorded in the official catalog, the gate steward must move the dog in the run order, and the scribe sheets must be re-arranged. The dog shall remain in the higher height for the remainder of the weekend or set of back-to-back trials unless a subsequent measurement done by a VMO or Agility Field Representative puts them in the lower jump height. If a higher measurement is done by a VMO or Agility Field Representative, at the handler's discretion the dog may be moved to Preferred. The move can be lateral (at the corresponding level) or, if they don't have the Novice Preferred title, to the Novice level.

Dogs entered in Preferred classes shall be moved to the proper jump height if measured into that height by a Volunteer Measuring Official, Field Rep or judge of record.

Each individual measurement for a permanent card must be done by a different VMO or Field Rep. VMOs must put their judge's number at or below their signature on measuring forms.

Host club responsibilities: Host clubs shall provide the judge with an official measuring device and a suitable location to measure dogs that require it.

Additionally, the club shall provide assistance in the check-in and measuring process to ensure that all dogs are measured and recorded properly.

SECTION 3. Course Setting

Host club responsibilities: Course setting is primarily the responsibility of the host club. The host club is responsible for providing properly trained personnel, including a Chief Course Builder (CCB), and enough help to ensure efficient changes from class to class. Using the judge's course designs (drawn to scale with grid lines or baseline measurements), the CCB shall, as precisely as possible, set the equipment in place and locate the start and finish lines. The CCB shall not stake or secure anything or place any bars until the judge has completed their walk through. After notifying the judge that the course is ready for review, the CCB and stewards shall accompany the judge to move or adjust any equipment that the judge requires. Upon final approval by the judge, equipment can be staked or secured in place; however, for Standard and JWW courses (excluding Premier), bars should not be set until the judge has measured the course twice for distance.

Judge's responsibilities: It is the judge's responsibility to ensure that the course is set as close as humanly possible to the course that was approved by the AKC, while accounting for site conditions as they relate to safety. It is highly recommended that the judge mark the location of any obstacle that is likely to move during the class.

If a CCB is struggling, it is advisable that the judge step in and help direct the course building process, perhaps teaching the process if it is appropriate. Judges must account for the fact that the CCB and ring stewards are volunteers and should always be treated professionally and courteously.

Electronic timers:

- The judge is responsible for the appropriate placement of the timing eyes on the course in relation to the start and finish obstacles. At the **start** obstacle, the electronic timers must be placed on the approach side. At the finish obstacle, the electronic timers must be placed on the exit side.
- For the tire, timer eyes should be placed at the bar-jump height of the class.
- Judges must be knowledgeable in how to enter (program) standard course time (SCT) into the electronic timer console. The best way to determine whether or not a dog has exceeded maximum course time (MCT) when using electronic timing is to have the SCT programmed in

so that when the MCT is reached the time will stop and the horn will sound (if a speaker is attached). If a speaker is not attached, the Timer must then blow the whistle to indicate to the judge that the maximum time allowed on the course has been attained and the judge can direct the team to immediately leave the course.

- Judges are responsible for making sure that the correct SCT and/or MCT is programmed into the console for every class they judge. They are also responsible for ensuring that the eyes are programmed correctly for the number of times the finish obstacle is to be taken prior to the end of the course.

SECTION 4. Ring Crew Briefings

The ring crew that is going to work with you will need to be briefed as to the duties they are expected to perform. An experienced ring crew makes the briefing and the task of judging much easier; however, you should never assume that the ring crew knows fully what you expect of them, even though they may have done the job many times before. You should always brief the most important aspects of each job with all ring crew members regardless of their experience level. Be aware that a crew member may change even within a class and have to be briefed. It is also very important to have enough helpers to do all the jobs necessary for completing the trial. It is the host club's responsibility to provide a large enough ring crew to efficiently run the trial. It is the judge's responsibility to ensure that the ring crew is doing their job correctly. The judge must be courteous to all volunteers provided by the host club. If a volunteer is not up to the job that the host club has asked him or her to do, a reassignment may be in order. The judge should approach this situation cautiously and diplomatically so as not to offend the person involved.

The following is a list of the ring crew and their responsibilities. The judge shall ensure that the ring crew understands what is expected of them.

Score table stewards:

- Scribe sheets: Check with scorekeepers to make sure that they are using the proper (most current) scribe sheets for the class. Also make sure that they know how to translate the faults on a scribe sheet to a numerical score. Ensure that they know how to make the conversion for the dog's time, if written in minutes and seconds on the scribe sheets, to seconds, truncating down any partial seconds to whole numbers when comparing the time to SCT, and assigning the proper faults for any full seconds over SCT.
- Catalogs: Go through with the secretary how to properly fill out the catalog

that is to be submitted to AKC per Chapter 1, Section 25 of the *Regulations for Agility Trials*.

- Postings: Stewards should properly and promptly make the unofficial individual results available as they come in, enabling exhibitors to check their scores and times. Times (to the 1/100th of a second) for all dogs, qualifying or not, shall be recorded on the posting sheet, as well as qualifying status (Qualified, NQ, ABS or Absent, Excused, DQ, AIS, or AJC). A prompt posting of scores allows exhibitors the opportunity to question a score before the judge has forgotten the run. Any questions should be presented to the judge as soon as practically possible. Approach the judge during breaks for height changes or the fixing of equipment, such as adjusting a tunnel or a knocked-over jump upright.
- Checking catalogs: Instruct the table stewards as to the judge's need to check the scribe sheets against the official AKC catalog at the completion of each class and/or height division. Keeping the scribe sheets in catalog order will expedite the process. Results for the class's jump height must be checked by the judge before ribbons and awards are presented/made available. The judge shall review and initial all pages of the official AKC catalog for all classes judged.

Scribe:

- Watching the judge: After the dog's identity has been verified at the start line, the scribe should continuously watch the judge until the completion of judging.
- Scribe sheets: It is the scribe's responsibility to ensure that the scribe sheet matches the dog on the line. There are a number of ways to do this, but it must be done on a dog-by-dog basis, not by relying on scribe sheets that were put in order prior to the start of the class. Changes to running orders happen frequently due to conflicts and changes to a dog's jump height after measuring in, and the judge must be assured that the signals are recorded on the proper scribe sheet.
- Hand signals: The judge's hand signals should be reviewed so that the proper symbols are recorded on the scribe sheet.
- Scribe sheets should be scored using a pen, not a pencil. Changes should be crossed out and rewritten. All changes should be initialed by the person authorized to make the change (i.e. the judge, trial secretary, or scribe).

SCRIBE SIGNALS: STANDARD, JWW AND T2BTITLING CLASSES

Fault	Judge's Signal	Symbol recorded on sheet
Refusal/Run-out	Raised fist	R
Wrong Course	Raised open hand	W
Table Fault	Make a "T" with both hands or raise two fingers	T
Failure	Raised two open hands	F
Excusal	Blow the whistle	E

- Recording the time: The time shall be recorded on the scribe sheet precisely as they read it on the timer's stopwatch or e-timing console, to the 1/100th of a second. The scribe or timer shall not attempt to translate the minutes into seconds, as this slows up the class. It is the table steward's job to do all translations.
- Questions: Instruct the scribe to ask you about any signals that he or she may have a question about; sometimes a scratch of the head or wipe of the brow may look like a fault signal that was not intended.

Timer:

- Stopwatch/electronic timer operation: Ensure that the timer understands the operation of the stopwatch and/or electronic timer.
- The timer: Shall release the dog from the start line when the judge and scribe have indicated they are ready.
- Start and finish lines: The exact locations of the start and finish lines shall be briefed; the line on a start or finish obstacle is the finite space between the uprights of a jump, or the inside diameter of a tire or tunnel opening. The timer must be able to clearly see the entry and exit to the start and finish obstacles. Instruct the timer that the start line is live after the timer has instructed the exhibitor to start, and that any part of the dog breaking that line starts the clock, whether the exhibitor is ready or not. Any part of the dog crossing the finish obstacle as the next proper obstacle, in the proper direction, stops the time. However, if the dog has missed an obstacle near the end of the course or only missed the finish obstacle, and the handler has called the dog back to correct the missed obstacle, the timer shall keep the time running (or hit RESTART if the e-timer has stopped running) until the dog has properly executed the last obstacle in the correct order and direction (See Chapter 4, Section 14 of the *Regulations for Agility Trials*). For e-timing, instruct the timer that if the dog did not

physically start the time by going through the electronic beam but continued on through the course, as soon as the dog has completed the third obstacle the time must be started manually. This is used solely to know whether the team has exceeded the MCT. The timer must also be instructed to press the RESTART button (not the START button) when using e-timing if the last obstacle is taken as a wrong course including if the dog runs past the last obstacle and then takes it in the wrong direction, thus breaking the beam and stopping the time. If the time starts properly, fails to stop when the dog crosses the finish line, and is manually stopped by the timer, it is permissible for that time to be assigned to the dog's run vs assigning SCT or requiring a re-run for time if the handler is in agreement.

- Reducing stopwatch/e-timer malfunctions: Instruct the timer to look at the watch/e-timing console to ensure that it is running after starting each run. At the completion of each run, the timer should look again at the stopwatch/console to ensure that it has stopped. See Chapter 9 of these Guidelines for dealing with stopwatch/e-timer malfunctions.
- Whistles: The timer shall be equipped with a whistle or a working electronic horn/buzzer. If a dog starts across the line prior to being told to, the timer shall blow the whistle or press the horn/buzzer button, and the exhibitor shall be re-started if the error was deemed a mistake by the judge. If there is a stopwatch/e-timer malfunction identified while the dog is working the first three obstacles, the timer should blow the whistle or press the horn/buzzer button and the dog should be re-started. If a dog reaches Maximum Course Time (MCT), the timer shall blow the whistle or press the horn/buzzer button so the judge knows that maximum course time has been reached and the exhibitor must then leave the course. The judge must then blow their whistle as a follow-up to the timer (indicating that the scribe should record E and "no time" and that the dog and handler should leave the course), as many exhibitors do not hear the buzzer/horn.

Gate steward:

- When to enter the ring: The gate steward's primary job is to keep the class running smoothly by getting the exhibitors ready to enter the ring when instructed to by the judge. When clubs have opted to use armbands/stickers, the gate steward should ensure that all exhibitors are wearing their catalog number by visually comparing the number to the gate sheet; if the handler is not wearing a number to verify, they will not be permitted in to the course area. Usually the next dog is required to be on the line ready to go while there is a dog in the ring being judged. The handler should be instructed to remain with their dog at the start, under control and within reach until instructed by the timer to begin their run.

The judge must tell the gate steward at which obstacle in the sequence the next dog should move to the start. If the judge excuses the team currently running the course at any time prior to when the next dog would normally be directed to be ready on the line, the handler should be directed to enter the ring immediately to be ready to start.

- How many dogs ready to go: To ensure that dogs make it to the line on time and that there are no delays, the gate steward usually will look for the next three to four dogs in the run order (which should be posted ringside adjacent to the ring entrance) to be in close proximity to the ring entry and in correct running order.
- Check-in ringside: The gate steward shall keep a run order list ringside and use it as a check-in list so that exhibitors can see how many dogs are before them and how many have checked in. The gate steward also makes any changes to this list due to exhibitor conflicts, **per the judge's direction**. Since dogs must be run in catalog order except for those who have listed an approved conflict on the gate sheet, any dog not available for judging will forfeit its chance to compete. Approved conflicts are conflicts within a ring with multiple dogs, conflicts between multiple agility rings or conflicts with other venues on the same trial grounds.
- Jump height change notification: The gate steward should announce when the last dog in a jump height approaches the start line so that the ring crew can be ready to change the jumps at the completion of the run.
- Scribe sheet organization: Some host clubs ask that the gate steward organize the scribe sheets prior to the class. The gate steward should also verify each dog individually on a dog-by-dog basis, rather than a one-time basis prior to the start of the class, and relay this information to the scribe or scribe assistant.
- A-frame height change: It may be helpful to draw a brightly colored line on the gate sheet at the point in the running order when the A-frame height should be changed.

Ring stewards:

- Jump bar re-setting: Instruct the ring crew as to when displaced bars should be reset. Bars can be reset on jumps taken more than once if the course allows for resetting without interference with the dog or handler, except in FAST, where jumps must not be reset until the completion of the run.
- Tunnel straightening. The position of tunnels should be checked with greater frequency as the dogs get bigger. Large dogs can more readily displace the tunnel shape, which can change the challenges on the course and even the course distance.
- Changing jump heights: Instruct the ring crew as to how to set all equipment in their area of the ring.

Since ring stewards are often the least trained ring help, it is wise to check the double, triple, panel, and one-bar jumps prior to starting the first dog in each jump height, **and** each time any of these is reset after a run.

Leash runner:

- It is best to wait until the dog and handler have started their run to pick up the leash at the entrance, since this should be done in a fashion that does not disturb the dog. Leash runners should not throw leashes, which could potentially distract the dog. The leash runner must stay inside the ring while performing this duty since there may be times when the leash will need to get to the handler before the team gets to the finish.
- Leashes should be placed so that the handler can readily find it upon finishing the course. The leash shall not be set up as a target for the dog to run to (for example, right on the finish line). The leash must be placed in/on a container, hung on a holder, or placed in a bucket, on a chair, step stool, etc., but not on the ground or on the ring gating or barrier. All leashes must be placed in the same location as designated by the judge, not by the handler.
- Judges must brief the leash runner prior to the start of each class. Additionally, you should make a point of ensuring the leash holder is placed where you want it. Leash holders should be placed near, not at, the ring exit so that the dog does not accidentally step out of the ring while the handler is retrieving the leash, thus incurring an excusal fault.

Score sheet runner:

A runner that will carry the scribe sheets from the scribe to the score table is necessary. The runner should neither disturb the dog and handler in the ring or at the start line, nor distract the scribe from their job of watching the judge. The runner must give the scribe sheets to the score table **ONLY**. The exhibitor may look at their scored scribe sheet, but at no time may take possession of it unless it is a carbon copy.

SECTION 5. Measuring the Course for Distance

Judges must measure each course twice to determine the path of a 12" and 20" jumping dog respectively. These course measurements are used to determine the standard course times for the class. A judge shall use a measuring wheel to determine the distances a dog must travel to complete the course. All distances are measured on the ground and are based on the dog's expected path. A judge shall measure around the outside of open tunnels and adjacent to contact obstacles and the weave poles.

Things that affect the dog's expected path:

- 12" vs. 20" dog's path (small dogs require less distance to make a turn).
- In general, a judge should measure from the inside 1/3 of a jump to the inside 1/3 of the next jump for a 12" path, allowing less room for landing than the 20" path would.
- In general, a judge should measure from the middle of a jump to the middle of the next jump for a 20" path, allowing room for landing and turning.
- Surface and weather conditions should be accounted for when measuring. If it is slippery or raining, the judge may account for this in the path.
- The speed a dog is expected to be traveling when asked to make a turn will affect the turning radius. For example, a dog with a straight 3-jump sequence into a 180-degree turn will turn much wider than a dog coming off a table going into the same 180-degree turn.
- Courses are NOT to be wheeled "in advance". For example, if the course is currently set for Excellent Standard and there are only minor changes between that course and Open Standard, a judge is not allowed to wheel the Open course taking into account expected changes from the now-set Excellent course. The judge must wait until the Open course is actually built, then wheel.

SECTION 6. Standard Course Time (SCT) Tabulations

After completing the measurement of the course for a Standard or JWW class (except Premier), the judge shall compute the Standard Course Time (SCT) for each jump height and the Maximum Course Time (MCT) for the class. The judge converts the wheeled footage on the course to yards by dividing by 3 and rounding up to the nearest whole number if it is 0.5 or higher and rounding down if it is 0.4 or lower. This number is divided by the rate of speed assigned to each height and class level to determine the SCT (refer to the Regulations for rate of speed required in each height and class level). If the resulting value is not a whole number, it shall be rounded to the nearest whole number, with fractions of 0.5 and higher rounded up. The MCT for the class is determined by adding 20 seconds to the highest SCT. This whole number may be used for all dogs in the class.

SCTs in Excellent/Master Standard and Excellent/Master Jumpers with Weaves classes: There are maximum allowable course times (course time limits) assigned in the Regulations for all Excellent/Master classes. These course time limits may not be exceeded by the judge, regardless of the course length, running surface, or weather conditions. The AKC records computer will not accept course times greater than the maximum times published in the *Regulations for Agility Trials*. If the time limits are exceeded, the course must be adjusted to shorten the path; do not just assign the maximum allowed time.

All judges must retain for a period of one year a written record of the yardage that they wheeled and the SCTs calculated during their judging assignment.

SECTION 7. Exhibitor Briefings

The briefing for exhibitors should be delivered in such a way that puts exhibitors at ease. The regular and preferred classes of the same level should be briefed at the same time. The briefing should be short, but it should include the following:

- Introducing yourself and welcoming exhibitors to the host club's agility trial.
- Where to enter and exit the ring, including the reminder that when exiting the course area, the dog must be on leash. The exhibitor shall put the dog on leash as soon as possible per the Regulations. It is required to have a dog on leash prior to exiting the ring, since a leash is required on the trial grounds. A handler may carry his or her dog into or out of the ring (nicely of course) but the dog must still have a leash on for the entry and exit.
- When you want the next dog on the line and how many should be waiting in line.
- If the club opted to use armbands/stickers, the need for all exhibitors to wear the club-supplied armbands or stickers in an appropriate place and in plain view for the gate steward to see.
- The yardages and standard and maximum course times if known at the time of the briefing. Otherwise, an announcement will need to be made with a posting of the yardages and SCTs at the gate steward's check-in board.
- Any potential safety issues.
- How conflicts with other rings, multiple dogs or obedience or conformation will be handled.
- Reminding handlers that during a run, only flat or rolled, buckle or snap "non-corrective" collars are allowed. This does not include flat collars that cinch closed such as a martingale-style, braided leather or "double- ringed" collars. No attachments are permitted (including loose rings) on collars. It is permissible for an exhibitor's dog to be wearing a flea collar in the ring during a run. Only one collar is allowed; the dog may not be wearing both the flea collar and a buckle/snap collar during a run.
- For Standard classes, the 4-paw safety rule, your table count, and which side of the table is considered the back for run-out purposes should be addressed.
- Instructing the handler to stay with their dog until the timer has told

them to begin their run, or they may stand to lose their lead-out advantage or be cited for training in the ring.

- Answering any questions.

SECTION 8. Course Walkthroughs

Exhibitors need time on the course to plan their handling strategy. This walkthrough period should be timed, and generally should be a set 8 to 10 minutes long for each group walking. Judges should consider splitting walkthroughs when the entry in a class exceeds 60 dogs. If walkthroughs are split, 8 minutes per group is the suggested length of time. When splitting walkthroughs, it is recommended that you let the first height(s) walk the course, and judge those dogs. Then let the next height(s) walk, and judge those dogs. This way no one will have to wait hours after walking their course before they are allowed to run it.

If the entry is greater than 60 dogs **within** a singular jump height and is split for walkthroughs, all dogs within that height shall walk the course before judging begins.

To avoid exhibitor confusion with split walkthroughs, it is highly recommended that:

- The same policy exists in all agility rings when there is more than one ring. Judges should confer prior to the first class on the first day of any set of trials to agree on which classes will have split walkthroughs and how the classes will be split.
- The same policy stays in effect for all consecutive days of a trial, unless it really isn't working. Exhibitors get used to a system, and if there is a change, there will likely be exhibitors who will miss their walkthrough since they were relying on things staying the same.

There are times when an 8 minute walk-through may not be necessary. An example is a small class where there is lots of room to walk the course, and everyone on the course is satisfied and leaves before the 8 minutes are up. Another examples is that a ring may be built that is available while the other ring is running, and is opened for competitors to walk. Common sense should dictate whether less than 8 minutes is adequate.

After the last walk-through, the course must be cleared so that no exhibitors are walking the course. Once the course has been cleared, a five minute period must be given before judging begins. Judges should use the electronic count down timer whenever the horn and/or display are available.

There are some exceptions where a 5 minute period after the walkthrough may

not be necessary:

- For classes where at least the first 8 competitors in the running order are ringside and ready. Under no circumstances are these 8 competitors to be rushed in any way and if they need the full 5 minutes to prepare, then you must allow the full 5 minutes.
- When there is a large class and the walkthrough has been split, so that the first competitors walk the course, then leave for the 8 minutes for the second set of competitors to walk the course. In this case, the first group has had 8 minutes to prepare and may begin running the course immediately upon clearing the course of the second group. You may address conflicts this may cause.

Judges are encouraged to use the five minute period to:

- Brief the gate steward
- Check the gate board to be sure your instructions are being followed
- Brief the leash runner
- Place the leash holder
- Brief the bar setters
- Brief the timer and scribe
- Enter SCT in the timer console
- Get a bottle of water
- Check to be sure bars aren't "pinched"
- Walk your judging path

SECTION 9. Dealing with Ring Conflicts

To the extent that it is practical, dogs will be judged in catalog order within each class level. Exhibitors have paid to enter the trial and to the greatest extent possible should be allowed to run. Approved conflicts are conflicts within a ring with multiple dogs, conflicts between multiple agility rings or conflicts with other venues on the same trial grounds. After consulting with those who have conflicts, judges can handle conflicts in any way they deem reasonable. Handlers with more than one dog who need more separation between their dogs may have their first dog moved forward or their second dog moved later in the height class. Under no circumstances may they switch the order that the dogs were to compete within the same jump height. However, it is acceptable to change the order of the dogs if the dogs compete in differing jump heights. Usually, holding dogs that have a conflict until all others have run will work. In this case, just move them to the end of the order and reset the bars once all dogs without conflicts have run. Occasionally, this will not work, especially if a dog is entered in Conformation classes. In this case, you may need to move dogs to the beginning of a class, or to wherever it works best, providing the least disruption to the rest of the class. Conflicts not noted on the gate sheet must run in catalog order or lose their opportunity to participate in the class.

Upon completion of a class, the judge shall direct the ring stewards to reset all bars for any dog handlers that notified the gate steward of a conflict and had not yet run. The judge may allow a very short walk through if it is determined that the exhibitor did not get to walk through with the rest of the class. The judge shall then judge those dogs that had a conflict. A judge is not required to hold a course, waiting for exhibitors who had missed their run, if they are not present upon completion of the class.

SECTION 10. Warm-Up Jump

Warm-up jumps are recommended per the Regulations and if used, there shall be a maximum of one warm-up jump for each ring, and each warm-up area shall be separated so that jumps may not be put together or sequenced. The warm-up area is for warming up the muscles of the dog, not for training. Place the warm-up jump, if possible, in an area that you might be able to see it from the ring so that any major abuses can be seen, but not so close that it will disturb dogs competing in the ring.

CHAPTER 5

JUDGING

SECTION 1. Judging Position

As a judge, it is your responsibility to be in proper position to judge the performance of the dog on each obstacle. Proper judging position is facilitated by good course design. Your judging path should allow you to move efficiently around the ring without racing the dog or handler to be in the proper position. Remember, you are the judge not the handler, and your movements should generally be more constrained than those of the dog and handler. Prior to judging dogs, you should go over your judging path several times to make sure you are comfortable with the path. Also, remember that your judging path was approved by a Field Rep and should be adhered to as closely as possible while judging the course. If any major changes are made to your approved path, they must be documented and included in your report to the Director of Agility.

Judge's interference: The judge's position can cause interference with the handler or dog if not planned properly. The judge's path should avoid situations such as:

- Crossing in front of the dog's path as the dog is coming at you, as this can distract the dog (see diagram 5.1.1).
- Sharp turns off contact obstacles, which turn the handler toward the judge's position, and may cause the judge to be in the way or to not be in the proper position to judge the contact in the first place (see diagram 5.1.2).
- Placing obstacles that would require the judge to be in very close proximity to the dog and handler to be in the proper position to make a call (see diagram 5.1.3).

Required judging positions for obstacles: *Remember: Your calls will hold much more weight if the exhibitors see that you are putting forth your best effort to be in the proper position to judge their dog's performance.*

- **Contact obstacles (A-frame, seesaw, dog walk):** The judge is required to be within 20 feet of each judged contact zone when the dog is performing the contact obstacle. The judge must see the approach to all contacts, including the A-frame and dog walk to determine refusals, and must be confident that they can see everything happening at those entry points. It is important to stay mobile and keep moving. You may think you are in the perfect position to judge the contact zone, but then the handler will make a movement that puts him or her in a position to block your view of the dog.

- **Pause table:** The judge must be within 20 feet of the table at some point during the count of 5 seconds, and must be able to maintain that position and still get to the next judging position in time. The judge must look for contact between dog and handler and ensure that the dog has gotten completely on the table and stays on the table. The judge may be moving while counting; however, the judge must keep the dog in sight **at all times** and the handler must be able to hear the count. Judges should not be any closer than 5 feet to the table so that they do not distract the dog.
- **Broad jump:** The judge must be within 30 feet of the broad jump to judge whether a dog has visibly moved or stepped on or between any of the broad jump boards. Additionally, the judge must be to the side of the broad jump, for it is difficult to judge the broad jump if the dog is jumping directly away from or towards you.
- **Wall jump:** The judge must be within 30 feet of the wall jump to judge whether a dog has visibly displaced or moved any of the “tops.” The judge’s path must be to the front or back of the jump to see each “top.”
- **Weave poles:** While there is no finite distance beyond which a judge must not be when judging the weave poles, the judge must be comfortable that he or she can see:
 1. That the dog gained proper entry (without passing the refusal/runout plane).
 2. That the dog is weaving between each pole.
 3. That the handler is not making contact with the dog or the weave poles.
 4. That the dog has exited the poles in the proper direction and has not skipped any poles.

Avoid judging the weave poles directly from an end, as it will be impossible to see if the dog skips any poles in the weaving sequence. A position that allows you an angled view from alongside the weaves is best.

- **Jumps (bar jumps, one-bar jumps, panel jumps, double bar jumps, ascending double bar jumps, and triple bar jumps):** Jumps may be judged from a considerable distance away; however, judges must be able to see that the dog has cleared each bar, that the bar has not been displaced from its cup or support, and that the dog has jumped the bar and not the wing. Jumps constructed with large wings may require you to alter your judge’s path to ensure that you can see the bars themselves as the dog jumps them.

- **Tire jump:** The judge must be able to see the dog jump through the

opening of the tire without breaking it open. A position alongside the tire should be avoided, for it will be impossible to be sure that the dog went through the tire rather than between the tire and frame, or if the tire broke open slightly and snapped back together.

- **Tunnels:** The judge must be on the approach side of the tunnel with the tunnel opening in full view to enable the judge to call refusals and run-outs properly, and must see the opening of exits to know when a dog has all four paws out.
- **Wrong course possibilities:** The judging position shall account for off-course possibilities, as the judge needs to see whether the dog places one paw on or in the wrong obstacle. Therefore, the judge must be able to see all tunnel openings and all contacts that are a wrong course possibility in the course design (see diagram 5.1.4).
- **Judging position at options:** The judge shall stay in close enough proximity to see if the dog has crossed a run-out line or committed an off-course. A good rule of thumb is that if you have a lot of challenge in an area, you probably don't want to be too far away from that area to be able to judge all the possible things that can happen.

SECTION 2. Coordination with Ring Crew

Scribe and timer: The judge shall make sure that the timer and scribe are comfortable with and understand the system for matching scribe sheets to exhibitors in the ring prior to starting any class. The scribe is ultimately responsible for having the right scribe sheet to record faults signaled by the judge. The scribe shall indicate to the timer when ready, and the judge shall indicate to the timer when ready. The timer then gives an indication to the team on the line that everyone is ready for them to start their run, usually by pressing the “go” button on the console. If there is no speaker in use, statements such as “ready”, “please go”, “go now”, or “good luck handler” let the handler know the start line is live and it's time to get started.

Signaling the next dog to begin: Once the dog has completed its run and is under the handler's control, such as sitting next to the handler, or the handler has his or her hand on the dog's collar, you may release the next dog to run by signaling the timer to start them when the scribe is ready. You do not have to hold up the ring by waiting until all sections of the previous dog's harness or leash is attached.

Gate steward: Inform your gate steward to summon you between dogs if

there is someone who needs to question a score or discuss a conflict. If the jump height class is almost completed, waiting for the height change would be appropriate. The gate steward should also let you know if he or she is having a hard time getting exhibitors on the line as instructed in the exhibitor briefing.

SECTION 3. Judging Specific Obstacles

The Regulations state the performance requirements for each obstacle. The following is an obstacle-specific list of clarifications as to the intent of the performance standard for each obstacle listed in the Regulations.

Contact obstacles:

- To judge a dog's performance on a contact obstacle, a judge should focus on the contact zones and determine if a paw (or part of a paw) lands within this zone. This method provides better results than to watch the dog's movement over the board, for you may miss a back paw touching the contact zone as the dog is striding along the board.
- A dog is considered to be on a contact obstacle when on it with all 4 paws. Until a dog is on the contact obstacle with all 4 paws, it is subject to a refusal call.
- A dog is considered to have exited a contact obstacle when it has left the obstacle and all 4 paws have touched the ground.
- If a dog has completed a contact obstacle (exited the contact obstacle with all 4 paws touching the ground) and then re-engages the contact with 1 or more paws, the dog shall be assessed a wrong course fault.
- A dog shall not be faulted for the act of stopping, backing up, spinning, or reversing direction on a contact obstacle so long as the dog was fully on the obstacle when this occurred. The dog must ultimately complete the obstacle correctly by touching the descending contact zone before exiting the obstacle from the descent side.
- Once on a contact obstacle with all four paws, dogs may be stopped in the contact zone or partially on the contact zone and partially on the ground or with all four paws on the ground after the proper completion of the contact. If the dog is qualifying to that point, the handler may spend as much time as he or she wishes with the dog in this position. If the dog has NQ'd prior to the contact performance and the judge feels the handler is spending time working on a behavior rather than working the course, the judge should instruct the handler to move on. If the handler fails to do so, then the judge should excuse the handler for failing to comply with the judge's verbal instructions. Additionally, dogs that miss the contact and are corrected for missing the contact by being told to down or sit or by otherwise restricting their forward

movement should be excused for training in the ring as this is a punitive action. See Chapter 6, Section 6 for more “training in the ring” situations.

Offering a re-attempt: Judges should only offer/allow the handler to re-attempt the obstacle after an F has been incurred if, in the judge’s opinion, it was a true instance of the dog falling off the obstacle. Brief the exhibitor that he or she has the option to reattempt the obstacle and then leave the course, or continue on to the next obstacle and finish the course.

Non-faulted descent: A dog that is descending a contact obstacle would not be faulted for placing one or more paws on the ground prior to placing a paw in the contact zone, as long as the movement is in the dog’s natural stride. This may occur with larger or long-bodied dogs that, with their natural stride, move over the majority of the contact before a rear paw engages the contact zone. Therefore, a dog whose front paw(s) hit the ground first and whose hind paw(s) then come to rest or push off the contact zone is considered to have successfully performed the contact obstacle and shall not be faulted.

Faulted descent: Conversely, a dog jumping off a contact obstacle prior to placing a paw in a contact zone, even though it might inadvertently make contact with the bottom edge of the contact zone, shall be faulted for a missed contact (e.g., a dog that leaps off the board, yet a small portion of a back paw or the rear end or hock of the dog lands on the bottom edge of the board). In this instance, the dog typically gathers itself prior to touching the contact and then leaps to get off the board. Therefore, the dog left the obstacle with all 4 paws in an attempt to get off the board and the coincidence of the dog landing on the end of the board is not to be considered the proper performance of the obstacle.

Seesaw: To properly perform the seesaw, the dog may not exit the plank until the elevated edge hits the ground for the first time. The dog must touch the descending contact zone at the same time or after the plank has hit the ground. The dog may exit the plank any time after that, even if the plank has bounced and is no longer touching the ground. Exiting the plank before its elevated edge hits the ground is faulted with an “F” for a flyoff. Merely slamming the plank loudly into the ground is not faulted; however, the dog must still be in control and have touched the contact zone at the same time or after the plank touches the ground. If all 4 paws are on the seesaw and the dog has missed the up contact, the F is called and the dog may not repeat the seesaw even if they come off before they have 4 paws past the fulcrum, as they have already earned a failure to perform for that obstacle.

Pause table: A dog is not on the table until completely on it with all 4 paws.

Until a dog is completely on the table, the dog is still subject to refusal and run-out calls. The judge should immediately begin the table count once the dog is completely on the table. A dog has not exited the table until all four paws are no longer in contact with the table and the dog has forward momentum (i.e., if the dog is laying on its back on the table, the dog does not have forward momentum and is still on the table). If a dog has one or more paws in contact with the table at the conclusion of the judge saying, “Go,” then no fault shall be called.

- If the dog completely exits the table with all four paws before the count is completed and before the judge says the word “GO”, a table fault (“T”) will be issued, and the count restarts from the beginning once the dog returns completely to the table.
- Once the dog has successfully gotten on the table, if they exit early they may re-enter the table from any side; refusals and run-outs are no longer faulted.
- If the dog completely exits the table with all four paws during or before the end of the word “GO”, a table fault (“T”) will be issued for anticipating the count and the dog must continue on in the course. Thus, returning to the table after this fault will then constitute a wrong course.
- If a dog exits the table with one, two or three paws and is able to return completely to the table, no table fault is assessed and the count restarts from the beginning.
- If the dog leaves the table without completing the 5-second count and engages any obstacle, a table fault (“T”) shall first be given followed by “W.” If the dog returns to the table, the count is started from the beginning. If the dog does not return to the table, an “F” is given for failure to perform the table.
- If a dog is on a wrong course when the next proper obstacle is the table, the new run-out line of the table will be the side furthest from the dog’s logical approach (see diagram 5.3.I).
- If the dog is approaching the table (next correct obstacle), then alters its path within the last 1/3rd to avoid the front side, a refusal call must be called even if the dog ultimately jumps up on the table from the side (see diagram 5.4.5B).

Weave poles:

A refusal/run-out occurs in each of the following cases, when a dog:

- Enters the weave poles incorrectly.
- Misses a pole in the sequence and has to make any backwards motion.
- Stops before having all 4 paws cross between the plane of poles #1 and #2. Once the dog has fully entered correctly, it shall not be faulted merely for

stopping or sniffing in the poles.

- Runs by the entry to the weave poles without making the entry. Missed poles must be corrected by restarting the weave poles over from the beginning. Only the first missed pole during an attempt of the weave poles is called as a refusal until they are reattempted.
- At the Open/Excellent/Master levels, any action that is scored as a run-out or a refusal will count as one attempt.
- At the Novice level, any action that would normally be scored as a run-out or a refusal at the higher levels will count as one attempt. (See diagram 532)
- A subsequent attempt cannot be assessed until the dog has all four paws on the approach side of the run-out plane of the weaves.
- If a dog re-enters the weaves after 3 attempts - DO NOT whistle the handler off the course for the dog re-entering, even if the handler told the dog to re-enter - just tell them to go on. They may have not heard or been able to react quickly enough to your directions. This is very different from the handler that ignores your repeated direction to go on. They may be whistled off for failure to follow the judge's instructions or training in the ring.
- A dog who attempts the weave poles three times unsuccessfully and then moves on (per judge's verbal instruction) should be assessed three "R" refusals (except in Novice) and an F for failure to complete the weaves, but no "W" wrong course for progressing to the next obstacle after the weave poles, as the next obstacle is the next correct obstacle after three attempts at the weave poles.

A wrong course occurs in each of the following cases, when a dog:

- Performs the weaves in the wrong direction (back-weaving) by consecutively crossing the plane of the weave poles three times in succession.
- Crosses through the plane of the weave poles when it is not the correct obstacle in sequence.
- Crosses through the plane of the weave poles before getting on the approach side when the weave poles are the next correct obstacle.

Bar jumps: Only the top bar of the jump must be cleared without displacing it. If for any reason, one or more bottom bars fall and the top bar remains in place, the dog shall not be faulted. If a dog hits a bar and the bar is not displaced from its support, the dog is not faulted. Dogs shall not be faulted for "banking" off bars unless the top bar is displaced. If the last bar on the course falls as a result of an action by the dog, it does not matter whether the dog has already stopped the clock before the bar falls, the dog shall be faulted for displacing the bar. If the top bar is displaced and falls to a lower

support but not fully to the ground, an “F” must be signaled.

If a jump is to be taken several times on the course and the dog displaces it the first time through the dog is given an “F.” If the bar is not reset when the dog returns to the jump, a second F is not given as long as he passes between the stanchions.

Panel jump: If the top plank is displaced from its support, the dog is faulted whether the plank falls all the way to the ground or not.

Double bar jump and ascending double: If either of the two top bars are displaced the dog shall be faulted with an “F.”

Triple bar jump: Any displaced bar of the triple results in an “F.”

Broad jump: The corner markers are placed at the corners of the broad jump for the sole purpose of determining whether the dog has jumped over all of the boards of the broad jump. A dog that touches or knocks one of these markers over is not faulted per the Regulations. Dogs shall not be faulted for this act unless the dog fails to clear the broad jump as stated in the regulations. Any action of the dog that visibly moves the broad jump boards, as well as stepping on top of or between the boards, is a failure.

Wall jump: If any of the four “tops” fall to the ground, the dog shall be faulted with an “F.”

Start and finish lines:

- Dogs that run past the first obstacle or the last obstacle will incur a runout fault.
- No refusals will be assessed **prior** to the dog crossing the plane of the first obstacle; however, a wrong course will be assessed if the dog takes any obstacle on the course **prior** to starting the time normally by taking the first obstacle.
- When starting, handlers may set their dogs at any distance or angle from the approach side of the first obstacle; however, the dog must remain inside the ring. If the dog is not started from the approach side of the first/start obstacle, a runout fault will be assessed.
- Dogs that run past the last obstacle will not be faulted for failure to complete the course as long as they return and complete the last obstacle prior to the dog exiting the ring. The time will continue to run until the dog has completed the last obstacle. Handlers who choose not to return to properly finish shall be whistled and given a “No Time.”
- Dogs that run past the last obstacle and commit a wrong course by taking it in the wrong direction will be assessed a runout and a wrong course fault. If

using electronic timing, the timer will be tripped when the dog passes between the eyes during the wrong course, thus the timer must hit the RESTART button as soon as this occurs so that the time will continue until the dog has completed the last obstacle in the proper direction.

- For e-timing, the start line is the plane between the timer eyes. If the dog does not go through this plane (i.e. goes around the first obstacle) and continues through the course, time must be started manually when the dog takes the third obstacle.
- The finish line “plane” is a finite line that only extends across the last obstacle on the course (for e-timing, between the two poles of the electronic timer eyes). It is NOT an infinite line, as defined for an obstacle’s run-out plane. Additionally, the finish line is not “live” until the dog is in the “closing sequence”, defined as the dog completing the second to last obstacle on the way to the finish obstacle. If a dog completes the third to last obstacle, runs around the second to last obstacle, and takes the finish obstacle (incurring both a run-out and a wrong-course fault), the timer should re-start the time and the handler has the right to bring their dog back to complete the second to last obstacle, then complete the course and earn a valid run time.
- In the closing sequence, a handler that stops the time at the finish obstacle (instead of the dog) will be whistled (E).
- Dogs that do not finish the course must be whistled to indicate that an E and No Time must be recorded on the scribe sheet.

SECTION 4. Course Faults

Course faults include refusals/run-outs, wrong courses, table faults, failures/eliminations, and excusals. The following is a clarification to what is written in the current edition of the *Regulations for Agility Trials*.

Refusals and run-outs are similar faults in their nature and in how they are signaled and scored. They both relate to the fact that the dog is not getting on, in, or over the next proper obstacle like they should. In order to be subject to a refusal fault, a dog must be in a position to see the next proper obstacle before they can be faulted. For run-outs, the dog does not have to see or be in close proximity to the next proper obstacle for a fault to be called. See examples 54.1 through 54.7 for practical applications of course faults.

Refusals (R):

Refusals are the most difficult fault to assess, because they are somewhat subjective. A refusal is assessed solely on the performance of the dog, with no consideration given to what commands were or were not given by the handler, or to the location of the handler. In addition to the guidance provided in the

Regulations, the following may help you in understanding refusals:

1/3 – 1/3 – 1/3 Refusal Guideline: The 1/3 – 1/3 – 1/3 refusal guideline can be used to help define when a refusal can occur. To apply this guideline, the space between the previous obstacle and the next proper obstacle is divided into three equal spaces as follows. Note that the ranges in distances given are due to the range of obstacle spacing allowed on the course and are in relation to the next proper obstacle.

Furthest 1/3 (landing area) is the 1/3 of the course distance that is the greatest distance from the next proper obstacle.

Middle 1/3 (judge's discretion zone) is the middle 1/3 of the course distance between obstacles (usually 6 to 16 feet away from the next obstacle in sequence).

Closest 1/3 (refusal territory) is the 1/3 of the course distance just prior to the next proper obstacle in sequence (usually 0 – 7 feet away).

Judging of these 3 zones is as follows:

Furthest 1/3: It is highly improbable that you would call a refusal in this area. The dog is landing and needs this area to acclimate to the new position on course and see what options are available.

Middle 1/3: This is the area where you as the judge must determine whether the dog is in a position to see the next proper obstacle. Dogs in this area are subject to refusals if, in your opinion, the dog has had the opportunity to have seen the next proper obstacle.

Closest 1/3: Dogs in this zone are almost always considered to have seen the next proper obstacle whether approaching it directly, running parallel to it or spinning in front of it.

It is important to note that the closer a dog is to the next proper obstacle, the narrower its field of vision. Thus, the probability of it seeing the next proper obstacle is even greater. This is the basis of the 1/3 guideline.

Maneuvers by the dog to avoid an obstacle by altering its path are often obvious. The following examples should be faulted as refusals when they occur in relation to the next proper obstacle:

- Jumping over or passing through the wing of a jump in the correct direction.
- Jumping over a contact obstacle from side to side or jumping over a tunnel.
- Going under the top bar of a bar jump (in the correct direction).
- Passing between the tire and the frame (in the correct direction).
- Entering the broad jump correctly but exiting through the side.
- Entering through the side of the broad jump and exiting the other side or back.

- Exiting the entrance of a tunnel without going completely through the tunnel.
- Going under or jumping over the pause table without touching it (see diagram 545B2).

A dog is not subject to a refusal until it has placed all 4 paws on the proper approach side of the obstacle (see diagram 543D).

If a dog is given a refusal for stopping in front of an obstacle, it cannot be given another refusal for just standing there. The dog is not subject to another refusal until it makes some movement forward. Furthermore, a dog that stops in front of an obstacle, then turns back on its path is assessed one refusal since there has not yet been movement forward toward the intended obstacle.

Run-outs (R):

A run-out occurs each time the dog passes the run-out line of an obstacle without engaging that obstacle. Whether the dog was approaching that obstacle or has even seen it is of no consequence.

The run-out line is intended to mark the point at which a dog can no longer properly engage the obstacle without turning back on its path. It is defined as a line that passes across the front edge of all obstacles except the pause table, weave poles, and contact obstacles.

- On the weave poles, the run-out line is interpreted as passing perpendicular to the weave poles to the left of the first pole and to the right of the second pole.
- On the pause table, the run-out line passes across the back of the table. The back is determined by the natural flow of the course. Thus, it is possible that dogs may jump on the table from three different sides (the front and the two sides) without incurring a run-out. To better define the run-out line, the front face of the table should be square to the expected dog's path.
- On the dog walk, the run-out line passes through the junction where the ascent ramp and the horizontal, middle ramp meet (see diagram 5.4.1).
- On the A-frame and seesaw, the run-out line passes through the back edge of the approach side's contact zone.

Once the dog has passed the original runout line of the table, the line then flips to the opposite parallel plane for the purpose of judging the dog's subsequent approach to the table. (See diagram 5.4.2B)

Run-outs occur immediately when they happen. Thus, in the case where a dog passes the run-out line for an obstacle first and then goes off course, the score

should read “R” for run-out and “W” for wrong course. However, if the dog goes off course and the wrong course obstacle carries the dog past the run-out line of the next correct obstacle, only a wrong course penalty is assessed (see diagrams 5.4.1 through 5.4.7 for examples).

A dog cannot be assessed a run-out until it has all 4 paws on the approach side of the next proper obstacle. This is especially important in situations, such as 270-degree turns, where the dog is not on the approach side of the next proper obstacle when it lands. The dog must land and then make its way to the approach side of the next proper obstacle (see diagram 5.4.3-D).

Wrong courses (W):

A wrong course is called when a dog performs the correct obstacle in the wrong direction. For example:

- Getting on the wrong end of a contact obstacle
- Jumping the next proper jump in the wrong direction.
- Entering the wrong end of a tunnel.
- Jumping backwards through the tire or backwards between the tire and frame.
- Back-weaving through the weave poles by consecutively crossing the plane of the weave poles three times.
- Back jumping the broad jump by entering through the rear of the broad jump and exiting through the side or front, or entering through the side of the broad jump and exiting through the front.
- Jumping over a contact or tunnel from side to side.

A wrong course also occurs when a dog engages an obstacle that is **not the next proper obstacle** to be performed. A dog is considered to have engaged a wrong course obstacle when the dog:

- Touches the obstacle with one or more paws (head, nose, shoulders, and tail are not considered).
- Jumps over any part of the obstacle.
- Goes under the table or a jump with one or more paws.
- Crosses through the weave poles with one or more paws.
- Placing one paw on an off course obstacle prior to starting the run, whether the dog is on or off leash.

If the weave pole 3-attempt is invoked, only a failure to perform fault is called. There is no wrong course called as the next obstacle is the correct obstacle to be performed.

Going under a contact obstacle is not considered to be a wrong course, unless the dog actually touches the contact obstacle with one or more paws.

Multiple obstacles taken while the dog is on the same wrong course are considered a single wrong course. The dog is not subject to additional wrong course penalties until it has engaged with one paw the next proper obstacle in the sequence.

If the handler has **chosen to remain in the area** of the next proper obstacle in an effort to get the dog to complete it, once the dog returns to the correct side of approach, they can again be subject to another refusal/runout since they are attempting to correct the wrong course and complete the next proper obstacle.

Eliminations/Failures (F):

Failures are infractions on the course that prevent the dog from qualifying at any class level. However, the handler and dog are allowed to continue and complete the remainder of the course. Judges shall continue to judge the remainder of the run, signaling all faults as described above even after a failure has been signaled. The Regulations contain a list of infractions that result in a failure being assessed. The following are some additional guidelines for assessing failures:

- If a dog omits an obstacle and the handler makes the decision to continue on without returning to complete the omitted obstacle, the judge shall signal a failure to perform (“F”), in addition to the possible “R” and the “W” already incurred, and then continue judging the dog’s performance from that point on.
- If a dog knocks a bar, panel, or wing down **while on a wrong course** and the dog has to complete that obstacle later on the course, the performance shall be faulted with an “F” for the knocked bar, panel, or wing (whether it is reset or not). The bar, panel, or wing being knocked down was a result of the dog’s action and the score shall not be dependent on a ring steward’s abilities in replacing the bar, panel, or wing. If the bar, panel, or wing is not to be taken in the remainder of the course then the dog would not be assessed a failure to perform.
- Displacing a tire from its frame, whether it falls to the ground or not, is a failure. Knocking the tire open is a failure.
- Handlers who touch, jump over, or go under equipment shall be faulted with an “F.” If the action is extreme or dangerous, the judge should excuse the handler rather than signal the failure.
- If a handler steps on a ground support causing the equipment to fall over or the top bar or plank to displace, then an “F” must be assessed.
- Handler contact with the dog sometimes occurs on the course. Handlers may stand anywhere they wish in the course area to direct their dogs around the course (except for on the equipment). There are various reasons for contact, and not all should be faulted. The fundamental point in deciding whether or not to fault the contact is whether or not it aided the performance of the dog or whether the handler knowingly placed himself or herself in a position where contact was a possibility (e.g. in attempting to

enhance the dog's performance).

The following are examples of contact that would be faulted:

1. Any contact between the dog and handler at the contacts, table, or weave poles shall be faulted. In this case, the dog's movement is restricted by the performance of the obstacle and the handler has decided to place himself or herself in close proximity to the dog, usually to enhance performance. This places the handler under greater scrutiny, and any contact under such conditions shall be faulted.
2. Dogs lunging and touching the handler's hands because of the handler using his or her hands to guide the dog or "fake treat" the dog.
3. Handlers touching dogs by using knees or other body parts to guide the dog on, in, through, or off an obstacle.
4. Dog-handler contact or collision (inadvertent or not) that keeps the dog from going off course, picking up a run-out or refusal, or aids in the entry or approach to the next obstacle.

Examples of when a dog would not be faulted for contact would be:

1. Inadvertent contact between the dog and handler where no advantage to the dog has been gained and no fault has been avoided. *Exception: Any contact at the contacts, table and weave poles.*
2. Dogs jumping on handlers out of insecurity or excitement. This type of contact is innocent and should not be faulted unless the dog is nipping (see Excusals).

Excusals (E):

Excusals are infractions that are fairly serious in nature and result in the immediate end of the run. The judge shall immediately blow the whistle and instruct the exhibitor to leave the ring. The judge may need to explain to the exhibitor the reason for the excusal if it is not apparent. The length of the explanation and the general tone shall be dictated by the nature of the offense. Exhibitors excused from the ring must immediately and politely stop working their dog and leave the ring with their dog. Judges should consider filing a Misconduct for handlers not following their verbal instructions to leave the ring with their dog.

The Regulations contain a list of infractions that result in an excusal. The following are some additional guidelines for assessing excusals:

- **Excessive handling:** A handler should be excused when it is evident that the dog is completely untrained on the obstacles to the point that the dog would not be able to perform the obstacles without extreme movements on the handler's part. Some examples are a handler leaving the dog at one end of the tunnel and going to hands and knees at the other end to call the dog

through, and a dog that needs (fake) baiting by the handler throughout the entire course.

- **Harsh commands:** Some handlers get so excited that they start shouting their commands in negative tones. They usually are not even aware that they are doing this. In general, this should not be faulted, although you may bring it to their attention when you get a chance. Sometimes handlers become very frustrated with their dogs, particularly if they think their dogs are intentionally disobeying. In these cases, you can hear a distinct edge in the handler's voice. The best time to warn a handler that his or her commands are too harsh is when the dog is on the table, since it is usually under control at this time. Consider the extra time it takes to warn the handler as a penalty. If it is not convenient or if it is too late to warn the handler during the run, do not hesitate to excuse the handler. (See Responsibilities to Spectators in Chapter 1, Section 1 of these Guidelines).
- **Unsportsmanlike conduct:** Any instances of unsportsmanlike conduct should result in immediate excusal from the ring. In cases when the conduct is extremely severe, such as dog abuse in the ring or verbal abuse, the infraction may also warrant a misconduct hearing.
- **Dogs that leave the ring and/or discontinue working:** Dogs that willfully leave the ring during their run should be excused. This is different from a dog whose momentum carries it out of the ring due to obstacle placement in close proximity to the ring barrier. In this case, the dog would not be faulted. A dog that willfully leaves the ring does so through his or her own volition. Sometimes this is an avoidance of the agility equipment or handler or just an opportunity to check out a toy or treat, another dog, or some other outside inducement. The type of ring barrier shall not be considered when assessing this penalty.
- **Exiting the ring off-leash:** If a dog has exited the ring with all 4 paws prior to being on leash the dog is considered to have left the ring without a leash and an "E" must be called. Once all 4 paws are over the plane of the ring barrier the dog has left the ring. Judges can set up teams for success by placing their last obstacle further back than 20 feet and managing where the leash holder is set. Placing the leash holder next to the opening for the exit makes it hard for handlers and dogs to leave the ring safely.
- **Leashes and harnesses upon exiting the ring:** A handler may bring a dog into the ring on a harness and a slip lead. Upon exiting the ring, the handler may choose to put the slip lead on the dog, for expedience, leaving the harness unclipped, which is acceptable. However, some form of leash or harness must be completely attached/snapped/closed before leaving the ring. If the dog is not attached to a completely secure leash or harness before exiting the ring, the handler is subject to an Elimination for leaving "off leash."
- **Dogs that are unresponsive and/or out of control, including after the last**

obstacle.

- Fouling the ring: Dogs that foul the ring, including dogs throwing up, should be excused.
- Inappropriate collars: Discovery of an inappropriate collar on a dog after the run has started shall result in an excusal.
- Running the course with handling aids: Food, toys, and training devices are not allowed in the ring at any time. Articles of clothing such as glasses, hats, etc., if thrown for the dog to chase at the end of the round, would then be considered handling aids. Judges should not require exhibitors to remove keys, wallets, cell phones, pagers, etc., from their person, as just having them is not a training inducement. However, an exhibitor who uses one of these items as a training device, such as throwing it upon completing a run, or jingling keys in his or her pocket with a hand as an inducement for or punishment of the dog, should be excused.
- A handler who purposefully touches the dog (petting on a contact zone, picking up the dog to place it on the table or back on a contact zone), or the handler who uses negative touches, such as corrections, must be excused for training in the ring (see Chapter 9, Section 6 of these Guidelines). However, if the dog has fallen and the handler feels the need to check out the dog to make sure it is okay, the handler should receive an “F” for touching the dog, but not be excused for this act.
- Training in the ring: See Chapter 9 of these Guidelines for examples.
- Aggression of the dog towards the handler, judge, or ring crew: If a dog bites at its handler and holds on to clothing or continually attempts to nip at its handler, such that the run is more about not getting bitten than it is about agility, the dog must be excused from the ring. (Refer to Chapter 1, Section 1; Responsibility to Spectators in these Guidelines). If a dog is aggressive to the judge or ring crew, the dog must be excused (or disqualified depending upon the circumstances) and a report filed with the judge’s report.
- Failure to comply with the judge’s verbal directions: Use this area of the regulations when there is confusion. If the exhibitor fails to comply with your verbal instructions (directions based on the regulations and/or guidelines), he or she should be excused from the ring. The following are examples of when you may need to say something:
 1. If a handler absolutely refuses to be on the line as directed, has been warned by the judge, and is still not on the line, causing delays, this is failure to comply with the judge’s verbal directions.
 2. If there is confusion at the start line, and the handler has been told by the timer to go but does not go, the judge should say “go now.” If the handler fails to comply, he or she should be excused.
 3. If the dog just can’t figure out how to get into, on, through, or over an obstacle and the handler, after many attempts, continues

to try, the judge should tell the handler to move on to the next obstacle. If the handler fails to comply, he or she should be excused. Judges should allow a minimum of four to five attempts on each obstacle.

4. A handler who fails to heed the judge's warning about harsh handling is failing to comply with the judge's verbal directions.
- Dogs that get hung up going through the tire or fall off the descent side of a contact obstacle and, given the choice by the judge, the handler chooses to immediately reattempt the obstacle once, are then required to leave the course
 - If a dog gets "stuck" on a contact obstacle, it is okay for the handler to hold the dog's collar and help him finish the obstacle. It is also okay for the handler to help navigate the obstacle, such as gently pushing the seesaw board to the ground. The team would then be excused (whistle). The dog MUST initially have all four paws on the obstacle before "help" from the handler is allowed; the handler may not "help" the dog get onto the obstacle via holding the collar or touching the obstacle.
 - Dogs that do not finish the course must be whistled to indicate that an E and No Time must be recorded on the scribe sheet. This includes a dog that does not take the finish obstacle and thus never stops the time.
 - Veterinarian: The only situation that would require the judge to request the services of the show veterinarian would be when a dog in the ring requires immediate medical attention or when a judge needs the show veterinarian's recommendation concerning the health of the dog in the ring. The judge must excuse a lame dog or any dog they deem as unfit to participate from competition (refer to the *Regulations for Agility Trials* Chapter 1, Section 31).

A dog does not need to be lame to be excused from the ring. Dogs whose actions make them appear physically unable to compete need to be excused for their own well-being. This can be manifested through many different actions on the dog's part including, but not limited to, avoiding obstacles, stopping prior to attempting obstacles, looking like each obstacle takes great effort to complete and/or just walking off around the course, ignoring the handler.

SECTION 5. Judge's Hand Signals

Standard hand signals:

The judge shall signal faults to the scribe by use of the standard hand signals and the use of the whistle, as described in Chapter 4, Section 4 of these Guidelines.

Correcting an incorrect hand signal:

If the judge inadvertently signals a fault, the judge should correct it immediately with the scribe once the dog has finished the run. The judge should go to the scribe and explain the change and look at the scribe sheet if there is any question as to whether the scribe has recorded the intentions of the judge correctly. This is also true if a judge wishes to add a fault that was not originally signaled on the course.

Signals for multiple faults that happen quickly:

Judges must be aware that scribes may miss a hand signal if many faults happen quickly on the course. Different scribes have different abilities to record a quick succession of signals from the judge; therefore, the judge needs to slow the process down so that the scribe can accurately record all faults signaled. If the dog has incurred several faults in a very short time, it is likely that the judge will need to slow the process down for the scribe. The judge may be signaling faults that happened even after the dog has left the area where the faults were incurred. To help the scribe out, deliberately and confidently raise your hand with the proper fault signal then lower it. Each fault should have a separate raise of the hand to identify a separate fault. Switching hands for faults that happen quickly will greatly help the scribe understand that you have signaled separate faults rather than hesitantly signaling the same fault when using the same hand.

Follow these steps to ensure accuracy in recording your hand signals:

- Make sure that your scribe knows the proper letter to record on the scribe sheet for each hand signal.
- Do not signal a fault until after it has happened. Sometimes judges can see something coming and will start to fault the dog, but the dog makes a great recovery, resulting in no fault. In this case, you would need to fix the incorrect signal at the end of the run.
- Do not raise your hand to signal a fault until you know which type of fault it is that you are going to signal. Do not raise your hand in a fist and open it up into an open hand once it is up. Scribes will wonder if this is an “R” or a “W,” thinking that you changed your mind while raising your hand, or both an “R” and a “W,” thinking that you just didn’t bring your arm down.
- Hold your calls if the A-frame is between you and the scribe, until you are clearly visible.
- Switch hands for multiple signals that happen quickly
- Generally, you should never take your eyes off the dog since you may miss a fault. One exception to this is that when the dog has failed an obstacle, you may want to look at the scribe briefly as you signal the “F” to make sure that the scribe sees this fault, which will prevent the dog from qualifying.
- The signal to your scribe for an Excusal (“E”) is your whistle, blown loud enough to be heard by your scribe.

Remember, scribes are to be watching the judge, not the dog. Scribes can only record what you signal, no more and no less, so you must be clear in your signals.

Hand signals for the International Sweepstakes class (ISC):

A judge must be clear with the scribe regarding hand signals in the ISC Class, since they are different from signals used in the Standard classes. The following is a list of the hand signals for this class:

- Use an open hand (which should be recorded as an “S”) for standard faults such as a knocked bar or missed contact zone. These are all 5-point faults.
- Use a closed fist for refusals and run-outs (same as in the regular classes).
- Use two open hands as an “F” for faults that will fail the dog and keep it from placing, such as a wrong course or handler-dog contact. This is done so the dog and handler may complete the course even though they have no chance of placing.
- Use a whistle for an excusal or when a dog has exceeded the fault limit if one has been imposed. Handlers should be encouraged to quickly exit the ring if excused. It is of no importance if the dog takes obstacles on its way out.

SCRIBE SIGNALS: ISC CLASSES

Fault	Judge’s Signal	Symbol recorded on sheet
Refusal	Raised fist	R
Standard Fault	Raised open hand	S
Failure	Raised two open hands	F
Elimination	Blow the whistle	E

CHAPTER 6

FAST CLASS

SECTION 1. Course Design

All courses must meet the usual safety standards set forth in the *Regulations for Agility Trials* and elsewhere in these guidelines. In addition, the following factors must be taken into consideration when designing courses for the FAST class:

- All courses must adhere to spacing requirements indicated in the AKC design guidelines.
- The course must have a start line(s) or start jump. A start line must consist of a single straight line or two intersecting straight lines, allowing handlers wide latitude when planning their strategy. A visible marker (such as a stanchion or cone) must be placed at each end of the start line(s) to provide a line of sight for the Timer. A start jump must be indicated with a start line or text on the map, it must be a winged bar or 1-bar jump marked as unidirectional or bidirectional, and it may be pointed. The start line/jump must allow handlers wide latitude when planning their strategy; different starting paths must be available.
- No obstacle, including the finish obstacle, may be placed on the approach side of a start line; however, obstacles may be placed on the approach side of a start jump.
- A winged bidirectional bar or 1-bar jump or a tunnel must be designated as the finish obstacle; to improve efficiency and for safety, it is recommended that it be placed in close proximity to the ring exit.
- If the finish obstacle is a jump, it may be assigned a bidirectional point value.
- The start line and finish obstacle must be placed so as to allow for hand timing. The finish obstacle must be placed on the course in such a manner that would not require the timer to move from one static position.
- The start and finish obstacles must be different obstacles and for safety reasons must not be placed near each other.
- A Send Bonus consisting of 2 (Novice), 2 or 3 (Open), or 3 (Excellent/Master) obstacles must be designated. The Excellent/Master level Send Bonus must have a change of direction or discrimination element included. Handlers must have multiple paths available to get into and out of the send area for strategic variety.
- Obstacles that are part of the Send Bonus must be the required distance from the send line when measured from the closest end of the jump bar (not from the edge of the wing), or the closest edge of non-jump obstacles (see diagram 6.1.1). In Excellent/Master, the Send Bonus obstacles must be 5-25 feet from the send line; no more than one

obstacle may be closer than 15ft and no more than one obstacle may be more than 20ft. In Open the distances must be 5-20ft; if there are two obstacles in the Send Bonus, one must be 10-15ft; if there are three obstacles, no more than one obstacle may be closer than 10ft and no more than one obstacle may be more than 15ft. In Novice the distances must be 5-10ft.

- The exit of an obstacle that is part of the Send Bonus may be placed closer to or further from the send line than the mandated handler restriction distance for the class level; however, no obstacle may terminate on or past the Send Line. *The only exception is that at the Novice level, contacts and weave poles, if used as part of the Send Bonus, must be a consistent 5 feet from the send line (i.e. both the start and finish of the obstacle must be 5 feet from the send line).*
- The contact obstacles and Send Bonus must be positioned in such a way that the judge can consistently judge all contact zones, identify refusals and runouts on obstacles that are a part of the Send Bonus (other than the first Send Bonus obstacle), and determine whether the handler has crossed the send line prior to completion of the Send Bonus.
- Jumps designated as being worth 1 point should be winged when space allows. Bar jumps or one-bar jumps may be used.
- A single set of weave poles (9-12 poles) must be used. The required number of weave poles may be placed in the body of the course or may be part of the Send Bonus. The weave poles may not be separated into two or more smaller sets.
- The sum of the point values of the obstacles that make up the Send Bonus must be between 5 and 15.
- All other obstacles other than the seesaw and broad jump are bidirectional (i.e. they may be taken in either direction to earn points). However, the judge may designate one or more obstacles that can be taken in only one direction to earn points; this is usually done to increase the difficulty of the course.
- A single bidirectional obstacle may be designated as a dual point value obstacle (i.e. worth a certain point value when taken in one direction and a second point value when taken in the other direction). A dual point value obstacle may not be taken back-to-back to earn points, except for a tunnel taken consecutively in the Send Bonus. A dual-pointed obstacle used in the Send Bonus may be unidirectional (the first pass must have the higher value); if that obstacle is a tunnel, it may be taken consecutively but only with the same entrance end (the exit cannot be the next obstacle's entrance). A dual-pointed obstacle not used in the Send Bonus must be bidirectional and cannot be taken consecutively for points.
- Approach angles and obstacle spacing for obstacles that are part of the Send Bonus must adhere to guidelines for the class level.

- Obstacles in the body of the course must be placed with a minimum of 8 feet of clear space from the send line to minimize the risk that handlers will run into these obstacles while directing their dogs through the Send Bonus.
- A minimum of two unique contact obstacles are required to have a point value.
- A maximum of three passes through tunnels are allowed to be used in a FAST course, with a maximum of two passes in the send. If a tunnel is used as the finish obstacle, that counts as a pass.
- The tire, triple, wall jump, ascending double and table are not allowed in FAST.
- At the club's discretion, any/all FAST levels may be designed to be combined into one course with embedded Send Bonuses for each level. Levels may walk together (club's option) with send lines noted for each level. Multi-level courses may have a maximum of two separate send areas. Point values may not change between obstacles (this would require a separate walk-through), but may change within an obstacle (for example, a unidirectional becomes bidirectional).

Course submission requirements

In addition to the elements required on all courses submitted for review, the following elements must be included on all FAST courses submitted for review:

- The 5-7 jumps designated as being worth 1 point and the 9 obstacles (or combination of obstacles) designated as being worth 2 through 10 points must be indicated. Numbers indicating point values must be placed in such a manner to clearly indicate whether the obstacle is unidirectional or bidirectional (see diagram 6.1.2).
- The finish obstacle (bar jump or tunnel) must be indicated.
- The start line/jump must be indicated.
- The timer position must be indicated. The timer must be positioned so that he or she can sight along the plane of the start line, or see the start jump, as well as see the plane of the finish obstacle.
- The entrance and exit to the course must be shown with the entrance closest to the timer/scribe for verification of the correct scribe sheet.
- The distance from the entry point of each obstacle in the Send Bonus to the closest point of the Send Line must be shown.
- The general judging area must be indicated.

Adding interest to FAST courses

Although the wide latitude in obstacle selection, including selection of obstacles in the Send Bonus, and obstacle placement allows for a great variety among FAST courses, additional factors can be used to add interest to individual courses:

- Use an obstacle that is not assigned any point value to assist the flow into

the Send Bonus.

- Use a 1-point jump (unidirectional or bidirectional) in the Send Bonus.
- Use a change of direction and/or obstacle discrimination in the Send Bonus at the Open level.
- Use one combination of obstacles in the body of the course that is assigned a single point value. Combinations should consist of 2 or 3 obstacles (in Novice, combinations may only consist of 2 obstacles). A combination may not be used in the Send Bonus. A combination is considered one obstacle with one point value. When combining pointed obstacles within a combination, the pointed obstacles must not coincide with the combination point values (see diagram 6.1.3). When combining levels in one course, combos must be adjusted to fit the level's combo requirements. In Excellent/Master, the combo can be 2-3 obstacles executed properly in a specified order; in Open, 2-3 obstacles executed properly in a specified order, or a single indicated obstacle can be taken for the point value (no longer a combo for that level); in Novice, 2 obstacles executed properly in a specified order, or a single indicated obstacle can be taken for the point value (no longer a combo for that level).
- Offer more than one choice for the Send Bonus. However, keep in mind that taking a Send Bonus obstacle in the correct direction before attempting the Send Bonus results in a fault, so avoid overloading your Send Bonus or handlers may be forced to attempt it early, restricting variety in strategy.

SECTION 2. Judging General Requirements

- If a start jump is used, dogs must take the start jump in the correct direction to begin their run (defined as passing between the stanchions). If they engage any other obstacle first (with at least one paw), FAULT will be called and the timer will manually start the time. This includes taking a unidirectional start jump the wrong way.
- No obstacle may be taken back-to-back in an attempt to earn points (except a consecutively-taken tunnel in the Send Bonus) or the second pass will not be awarded points. Thus, if an obstacle has been committed to with all four paws in either direction (regardless of whether faulted or not), it may not be immediately reengaged from either direction to obtain points; another obstacle must be attempted first. The weaves are an exception; if the weaves are engaged, they may be reattempted immediately from the same end for points without attempting another obstacle first. After engaging one end, in order to earn points from the other end another obstacle has to be attempted first. A combo is treated like one obstacle. Once any obstacle in the combo is engaged, the combo is live. If any obstacles are faulted or

taken out of order prior to the successful completion of the required number of obstacles, the combo is negated. Another obstacle must be attempted before re-attempting the combo for points.

- The same contact obstacle may not be taken back-to-back in an attempt to earn points. However, points may be awarded for two different contact obstacles taken in succession. Handlers may direct their dogs to complete obstacles multiple times without penalty. As long as the handler is not being mean or harsh, the handler may direct the dog to multiple completions and use the allotted time any way he or she wishes.
- No bars or panels on any jumps will be reset during a run.
- Points are awarded only for obstacles successfully completed before the Standard Course Time whistle is blown. A dog is considered to have completed an obstacle when all four paws have touched the ground after the obstacle. This includes all four paws on the ground after a jump, all four paws out of a tunnel, all four paws past the plane between the second-to-last and the last weave pole, and all four paws on the ground after a contact obstacle.
- Once the SCT whistle has blown, no further points will be awarded.
- MCT shall be SCT plus 20 seconds.
- Because of the strategic nature of this class, any outside assistance will be scored as an “E”.
- Handlers that jump over or cross through obstacles must be faulted. The judge shall blow the whistle excusing the handler from the ring and the scribe sheet shall be marked with an “E” and no time entered (NT).
- The 3-attempt rule for weave poles shall only be administered when the weave poles are the second or third obstacle in the Send Bonus, when refusals and run-outs are being judged.
- If the Send Bonus has a choice of starting obstacles, the dog must be judged as starting the Send Bonus as soon as it takes one of the first obstacle choices in the correct direction.
- FAULT will be called if the handler touches equipment during the run.
- FAULT will be called for handler-dog contact that aids the dog.

Send Bonus requirements (diagram 6.2.1)

- The Send Bonus may be engaged at any time during the run after crossing the start line and before completing the finish obstacle.
- “FAULT” will be called if the handler is inside the send zone or stepping on the send line when the dog commits to the first obstacle in the Send Bonus in the correct direction or if the handler steps on or over the send line before the dog has completed all obstacles in the Send Bonus. The dog will be considered to have committed to the first obstacle in the Send Bonus when the dog has placed all four paws over, on, or into the obstacle and will be considered to have completed all obstacles in the Send Bonus

when all four paws are on the ground after the last obstacle in the Send Bonus.

- The handler and dog may pass through the send zone at any time during the run; however, the handler must be outside the send zone when the dog commits to the first obstacle of the Send Bonus in the correct direction. A dog is considered to have committed to an obstacle if it has placed all four paws over, on, or into the obstacle.
- Successful completion of the Send Bonus is worth 20 points. In addition, the point values of the individual obstacles in the Send Bonus are awarded. Thus, 25 to 35 points (i.e. 20 points for the Send Bonus plus 5 to 15 points for the individual obstacles) will be awarded when the Send Bonus is successfully completed.
- A dog may take any single obstacle in the Send Bonus in the un-pointed direction without penalty. However, if two Send Bonus obstacles are taken in succession in reverse order, “FAULT” will be called.
- If the first obstacle in the Send Bonus is completed in the un-pointed direction, the dog must complete another obstacle before engaging the first obstacle in the Send Bonus since the obstacle cannot be taken back-to-back for points.
- If a jump that is a part of the Send Bonus is taken in the un-pointed direction prior to attempting the Send and a bar or panel is displaced, “FAULT” will be called and the bar or panel will not be reset.
- If a bidirectional obstacle in the Send Bonus is taken prior to the start of the Send Bonus, “FAULT” must be called, because the obstacle was taken in the correct direction before the first obstacle in the Send Bonus was taken.
- If the dog places 3 or fewer paws onto or into the first obstacle in the Send Bonus without continuing on, the handler may have the dog immediately reengage the obstacle in an effort to earn the Send Bonus points without any penalty.
- Once the first obstacle in the Send Bonus has been completed, “FAULT” will be called if the dog refuses or runs by any subsequent obstacle, or takes a wrong course in the Send Bonus.
- If the weave poles are part of the Send Bonus, they must be completed correctly for the dog to earn the Send Bonus points. The weave poles are considered to have been completed correctly if the dog enters between the first and second poles in the correct direction and completes all poles in succession from the first to the last pole. The weave poles are considered completed when the dog has all 4 paws past the plane between the second-to-last pole and the last pole.
- “FAULT” must be called if the Send Bonus was never attempted.
- When the first obstacle in the Send Bonus is a contact obstacle:
 - If a dog has committed to the contact with all four paws and jumps off

- before beginning the descent, the dog must engage another obstacle before re-attempting the contact obstacle or “FAULT” will be called.
- “FAULT” will be called if the dog misses the up contact zone on the seesaw or if the dog misses the down contact zone on any contact obstacle.
 - “FAULT” will be called if the handler is on the line or inside the send zone when the dog gets all four paws on the contact in the correct direction.
 - When the first obstacle in the Send Bonus is the weave poles:
 - If a dog has committed to the weave poles with all four paws crossing the center line between poles one and two, and it misses a pole while weaving, the dog may directly re-attempt the weave poles from the beginning without engaging another obstacle first, just as they would do in the body of the course for the weaves. The weave poles must be correctly completed as a single set, while the handler remains outside the send zone.
 - “FAULT” will be called if the dog back-weaves or crosses through the weaves, thus incurring a wrong course for the Send Bonus, after having correctly completed the poles from the proper direction. If the dog has not successfully completed the poles and back-weaves, this is not a FAULT but another obstacle must be attempted before re-attempting the weaves.
 - When the first obstacle in the Send Bonus is a tunnel:
 - If a dog has committed to the tunnel with all four paws and exits the entrance with all four paws instead of completing the tunnel, the dog must engage another obstacle before re-attempting the tunnel or “FAULT” will be called.
 - When the first obstacle in the Send Bonus is a bar jump:
 - If the dog passes under the bar with all four paws, it is considered to have attempted the jump and a “FAULT” will be called if another obstacle is not engaged prior to reattempting the jump.

Finish Obstacle

- The finish obstacle is “live” at all times once the dog has crossed the start line; time is stopped and the run finished whenever the finite line of the finish obstacle is broken regardless of whether the obstacle was completed or not.
- If so desired, the handler may direct the dog to the finish obstacle any time prior to the SCT whistle being blown as part of the handler’s strategy to minimize any possible point loss due to time penalties.
- A dog cannot qualify unless a time is recorded, therefore dogs must cross the finish line to qualify.
- No penalty is assessed if the finish obstacle is faulted.

- If the finish jump is pointed, the points are earned if the dog completes the jump correctly (in either direction) before the buzzer/whistle marks the end of SCT.

Re-Run for Time

If the malfunction of the timing device is discovered after the run is over, the judge must check the scribe sheet to determine the following:

- If the Send Bonus was faulted, nothing further needs to be done and the run will be scored as a NQ.
- If the Send Bonus was awarded and the dog had obtained enough points to qualify, the dog will have to re-run for time, unless a video of the run is available to determine the time by clearly showing the start of the run, point accumulation, and the dog completing the finish obstacle before SCT or if the buzzer/whistle marking the end of SCT was heard by the judge during the run
- If the dog clearly completed the run under SCT, a re-run is not required and the handler may take SCT.

During the re-run:

- The dog's score will be set back to zero.
- The dog must complete the Send Bonus in the correct numbered order; however, the handler is allowed to enter the send area with the dog and will not be faulted for doing so.
- If the dog commits a wrong course in the Send Bonus, the error must be fixed by having the dog re-attempt and successfully complete the next correct obstacle. The handler does not have to re-start the dog at the beginning of the Send Bonus – just have the dog complete the Send Bonus from where it was faulted.
- The dog must complete each obstacle in the Send Bonus but will not be faulted for dropped bars, missed contacts, refusals or wrong courses.
- The dog is considered to have completed the obstacle when all four paws touch the ground after passing the uprights of a jump, the pivot point of the seesaw, the apex of the A-frame or hitting the descent ramp of the dog walk.
- The dog must complete the tunnel and the weave poles from start to finish.
- The body of the course will be scored as a new run.
- Dropped bars and missed contacts will not earn points in the body of the course.

If the malfunction of the timing device is discovered before the run is over, the timer shall blow the whistle or sound the timing horn to let the judge know there is a timing malfunction. The judge must check the scribe sheet to determine the following:

- If the Send Bonus was faulted, nothing further needs to be done and the run will be scored as a NQ. The judge may excuse the dog from the ring unless the judge feels that there was substantial time left in the run, and may instruct the timer of the remaining time and allow the handler to continue the run; however the run will still be scored as an NQ.
- If the Send Bonus was never attempted before the timer indicated there was a malfunction, the run will simply begin again with a score of zero. Since the Send Bonus was never attempted, the handler must stay outside of the Send Zone when the dog is attempting the Send.
- If the Send Bonus was awarded, the handler and dog must re-run according to the criteria listed above.

If the horn sounds after the dog has taken the finish obstacle, which indicates that the timer did not stop, the judge may offer the handler the option of either standard course time or a re-run for time, as long as the Send Bonus was awarded.

If the dog has taken the finish obstacle and the timer notices the time is still running, he/she may hit the STOP button. If this time is at or under the standard course time, the judge may offer the handler the option of either this time or a re-run for time, as long as the Send Bonus was awarded. If this time is over the standard course time but the horn correctly sounded, the judge may offer the option of this time or a re-run for time, as long as the Send Bonus was awarded.

In both these cases, the judge should check with the timer to determine that the time was started correctly at the beginning of each run prior to offering this choice to the handler.

Actions that Result in a Whistle Fault (Excusal)

- Harsh corrections or training in the ring, whether at the start line, during the run, or immediately after the run prior to exiting the ring. This includes touching the dog while on a contact or taking the dog's collar to guide it into the weave poles.
- Handler contact that aids the dog to the finish obstacle.
- Any action that would cause an excusal in the regular classes, excluding the Four Paw Rule. This also includes a handler that: i.e. passes through the plane of the weaves poles, jumps over the plank of the dog walk or runs through the uprights of a jump.
- A handler that stops the time at the finish obstacle instead of the dog passing the finish line to do so.

FAST Video Review for Points

If an exhibitor questions their point accumulation and/or qualification in FAST, the judge can view a video to confirm. In order to do this, the judge must have a map and be able to hear points called and/or see them signaled, and the points must correspond to the points on the course map. In the case of deciding whether the run was faulted or not, the judge must listen for “FAULT” or “BONUS.” It is important that the judge listen to the entire video, as “FAULT” or E/whistle may have been called toward the end of the run.

It is recommended that the judge look and listen to the video and call points as a scribe or trial secretary re-records what the judge calls.

CHAPTER 7

TIME TO BEAT (T2B)

SECTION 1. Course Design

All courses must meet the usual safety standards set forth in the Regulations for Agility Trials and elsewhere in these Guidelines. In addition, the following factors must be taken into consideration when designing courses for the Time 2 Beat class:

- A minimum of 17 and a maximum of 19 obstacles shall be used.
- One set of twelve weave poles is required.
- If both the A-frame and seesaw are used, then each must be taken once. If only one is used, it must be taken twice.
- A minimum of five and a maximum of nine options, and at least three side switches are required.
- A maximum of three 180-degree turns may be used.
- One 270-degree turn is allowed.
- All spacing and approach/entry requirements shall be the same as in all other classes.
- No adjacent entrances (i.e. tunnel under the A-frame).
- A maximum of one double bar jump, one ascending double, or one triple bar jump must be used on the course.
- The double bar jump, ascending double, or triple bar jump may be taken a maximum of two times.
- Obstacles not allowed in T2B are: pause table, wall jump, dog walk, and broad jump. They may not be present on the course regardless if they are being used in the next class.
- One-bar jumps are allowed.
- The open tunnel may be taken only two times in the course flow; one tunnel may be taken two times, or two tunnels may be taken one time each.
- The judge may designate one tunnel or jump on course as bidirectional if there is a strategic element involved. If a judge opts to use a bidirectional obstacle, it must be marked on the map as such by placing the number at the midpoint of the obstacle's entrances (but not on the obstacle), with "bi" next to the number (see diagram 7.1.1).

SECTION 2. Preparing to Judge

Course times: The judge will not wheel the course for the purpose of determining SCT. The fastest qualifying dog in each Regular jump height division and each Preferred jump height division will set the winning time. That

time, to the hundredth place, will be the SCT for that jump height division.

The judge must ensure that the horn/whistle will sound if MCT is reached. For hand timing, the judge must brief the timer to blow a whistle at MCT as listed in the table below. For electronic timing, the judge must ensure the correct MCT is set for each jump height.

The following table shows the MCT for each jump height division, (regardless of whether the jumping height is Preferred or not):

<i>Jump Height Class</i>	<i>MCT</i>
4"	60 seconds
8'	60 seconds
12"	60 seconds
16"	55 seconds
20"	50 seconds
24"	50 seconds
26"	50 seconds

Preferred dogs will use the MCT of the height in which they are running, i.e. a Regular 20" dog running Preferred in the 16" height class will get an MCT of 55 seconds. The Regular and Preferred classes will be scored as separate classes and will each set their own SCT per height.

E-timer notes: To set e-timers that are version 2.6 or higher, SCT + 20 sec for MCT); enter 40 for the 4"/8"/12" jump heights (40 + 20 = 60 seconds); enter 35 for the 16" jump height (35 + 20 = 55 seconds); enter 30 for the 20"/24"/26" jump heights (30 + 20 = 50 seconds).

To set e-timers that have NOT been updated to version 2.6 or higher, thus are still set to calculate MCT as SCT times 1.5; enter 40 for the 4"/8"/12" jump heights; enter 37 for the 16" jump height; enter 34 for the 20"/24"/26" jump heights. Advise the club to get the e-timer programming upgraded.

Exhibitor Briefings: Exhibitor briefings for the Time 2 Beat class should include the following:

- A qualifying run requires that the course be completed under the MCT for that jump height, with no course faults.
- No refusals or run-outs will be called; however, the 4-paw rule will be in effect for each approach to the A-frame and/or seesaw.
- Three attempts at the weave poles will be allowed before the handler must move on in the course.

- Any course faults will result in a non-qualifying score (NQ).
- The course will not be wheeled for SCT since the fastest dog in the jump height sets the SCT.
- MCT for all jump heights.
- If the horn/whistle blows indicating MCT, the handler and dog must immediately leave the ring.
- If there is a bidirectional obstacle, indicate which one.

SECTION 3. Judging

General requirements

- Judging position and distance requirements are the same as in the Standard classes.
- Run-outs/refusals will not be faulted, including run-outs at the first obstacle. Any/all other course faults will apply as in other classes, and will result in an NQ.
- Three attempts at the weave poles are allowed before the handler and dog must move on to the next obstacle, resulting in a “Failure to Perform.”
- If a dog reaches MCT on a T2B course, the judge must blow the whistle. That signals the scribe to record “E” and “No Time” on the scribe sheet and that the run has ended and the dog and handler must leave the ring (the same as when a dog hits MCT on a Standard or JWW course).

Timer malfunctions: If a timer malfunction is discovered during a dog’s run within the first three obstacles, the timer will whistle or blow the horn to stop the run and the dog will start over. Any faults incurred will stand and judging will start at the point when the malfunction was signaled. If a timer malfunction is discovered after the third obstacle, the timer should wait until the dog has finished the run and then alert the judge. The judge will determine if the dog had a qualifying score. If it had course faults, no further action is needed. If the dog had no course faults:

- A video of the run may be used to determine the dog’s time if the start and finish are clearly visible.
- If no video is available, the judge must determine if he/she believes without a doubt that the dog ran the course under MCT. If so, the judge will offer the handler the option of receiving MCT minus one (1) second in lieu of the dog re-running for time.
- If the judge is not positive the dog ran the course under MCT, then the dog must re-run for time.
- All obstacles must be completed during the re-run; dropped bars, missed contacts, or wrong courses will not be faulted.

- Weave poles must be completed; this negates the three attempt requirement. If a weave pole is missed, the dog must start again at the first pole, just as during a regular run.

SECTION 4. Checking the Catalog

- At the top of the catalog page, the fastest time for that jump height will be listed; no yardage will be listed.
- Next to each dog's name, the dog's time (to the hundredth place) will be listed (if qualifying); no score shall be listed.
- The first place dog in each height division will have a "1" listed next to its time; no other placement shall be designated.
- All other dogs with a qualifying run will have a "Q" or "Qualified" listed next to their time.

CHAPTER 8

PREMIER

SECTION 1. Course Design

Premier classes have an emphasis on handling. Judges should design to require a team to demonstrate a higher skill level than would typically be seen on Master courses. All courses must meet the usual safety standards set forth in the Regulations for Agility Trials and elsewhere in these Guidelines. In addition, the following factors must be taken into consideration when designing courses for the Premier classes:

- Course designs must comply with the obstacles required, allowed, and not allowed as explained in Chapter 11 of the Regulations for Agility Trials.
- A minimum of 19 and a maximum of 21 obstacles shall be used.
- A minimum of three side-switches and a minimum of five options are required.
- A minimum of four Premier sequences/elements are required. (See diagram 8.1.1 for examples of Premier elements and rules for incorporating them. Judges can also suggest sequences of their own to their reviewing Rep).
- Required obstacle spacing should follow the requirements of the other levels of Standard/JWW, except where longer distances are used to provide more challenge.
- The judge may designate one tunnel or jump on course as bidirectional if there is a strategic element involved. If a judge opts to use a bidirectional obstacle, it must be marked on the map as such by placing the number at the midpoint of the obstacle's entrances (but not on the obstacle), with "bi" next to the number (see diagram 7.1.1).

SECTION 2. Preparing to Judge

Course Times: The judge will not wheel the course for the purpose of determining SCT. Maximum times for Premier are as listed in the tables below:

Premier Standard Course Times		
Hgt	Regular	Preferred
4	NA	70 sec
8	65 sec	70 sec
12	65 sec	65 sec
16	60 sec	60 sec
20	55 sec	65 sec
24	60 sec	NA

Premier JWW Course Times		
Hgt	Regular	Preferred
4	NA	55 sec
8	50 sec	53 sec
12	48 sec	50 sec
16	45 sec	47 sec
20	42 sec	51 sec
24	46 sec	NA

The timer can be set for a maximum course time of 70 seconds for all Premier Standard height divisions. The timer can be set for a maximum course time of 55 seconds for all JWW height divisions.

E-timer notes: To set e-timers that have been updated to the current system of SCT + 20 sec for MCT (version 2.6); enter MCT minus 20 seconds for the height division being judged. If multiple height divisions are being judged, enter the highest MCT minus 20 seconds, or enter 50 for Standard (MCT 70 seconds) and 35 for JWW (MCT 55 seconds).

MCT for all height divisions should be posted at the gate.

Exhibitor Briefings: Exhibitor briefings for the Premier classes should include the following:

- A qualifying run requires that the course be completed under the MCT for the height division with no course faults.
- MCTs are posted at the gate.
- If the course has a bidirectional obstacle, point it out and remind exhibitors that no Rs are called at a bidirectional obstacle.
- If the horn/whistle blows indicating MCT, the handler and dog must immediately leave the ring.

SECTION 3. Judging

General Requirements:

- Judging position and distance requirements are the same as in the other Standard/JWW class levels.
- At a bidirectional obstacle, run-outs/refusals will not be called; any/all other course faults will apply as in Master Standard/JWW classes, and will result in an NQ.

Timer Malfunctions: If a timer malfunction is discovered during a dog's run within the first three obstacles, the timer will whistle or blow the horn to stop the run and the dog will start over. Any faults incurred will stand and judging will start at the point when the malfunction was signaled. If a timer malfunction is discovered after the third obstacle, the timer should wait until the dog has finished the run and then alert the judge. The judge will determine if the dog had a qualifying score. If it had course faults, no further action is needed. If the dog had no course faults:

- A video of the run may be used to determine the dog's time if the start and finish are clearly visible.
- If no video is available, the judge must determine if he/she believes without a doubt that the dog ran the course under MCT. If so, the judge will offer the handler the option of receiving MCT minus one (1) second in lieu of the dog re-running for time.
- If the judge is not positive the dog ran the course under MCT, then the dog must re-run for time.
- All obstacles must be completed during the re-run; dropped bars, missed contacts, or wrong courses will not be faulted.
- Weave poles must be completed; this negates the three attempt requirement. If a weave pole is missed, the dog must start again at the first pole, just as during a regular run.

CHAPTER 9

WHAT-IFS WHILE JUDGING

This chapter addresses many of the non-typical things that can come up while judging. However, neither this chapter nor this booklet can cover all situations, nor can they substitute for common sense. For situations that come up that are not specifically spelled out, you will be required to make decisions that are fair and impartial for both the exhibitor involved and those against whom he or she is competing.

You should address any questions you have about judging procedure or conduct to the Director of Agility or an Agility Field Representative. Do not hesitate to call or write the AKC Agility Department. If you are judging at a trial and have questions and are unable to connect with any of the AKC agility personnel, the next person you should turn to would be another judge of record for that trial.

SECTION 1. Starting Errors

Various problems can occur at the start of each run, including exhibitors who delay starting the course after being told to go by the timer (delay of start), exhibitors who start too early prior to the timer giving the signal to go, and stopwatch/e-timer malfunctions. Listed below are various ways to handle these issues.

Delay of start: Sometimes the start area can be quite confusing for an exhibitor. Exhibitors are often trying to tune into their dogs and prepare for their run. At times, they may not hear the directive from the timer to go. Some handlers obsess at the start line and delay the trial for no good reason. To make it clear to exhibitors who seem to be having a problem hearing or understanding the timer, the judge should repeat the timer's directive to go. If the handler continues to delay, then the judge should excuse the handler for failing to comply with the judge's verbal instructions. The judge vocalizing the instructions to the handler takes away any confusion that can be claimed by the handler.

Exhibitors who start too early: In most cases, an exhibitor or dog that starts before the ring crew and judge are ready probably has done so out of nervousness or they were confused on whether or not to start. The judge or timer should blow a whistle once it has been discovered that the dog has been started without the timer's direction. If the judge has decided that the handler has acted out of innocence, the dog should be restarted at the beginning of the course once the ring crew and judge are ready. The dog should not be repositioned in

the run order, since the error was the handler's, and the handler cannot lead out from the dog. Any faults incurred would remain in place so long as the judge was in the proper judging position. Judging would, therefore, begin in the restarted course at the approach to the obstacle after the early start was discovered.

- If no faults were incurred prior to discovery of the early start, judging begins with the approach to obstacle #1.
- In cases where the judge was not in the proper judging position when an early start happened, judging shall begin at the approach to obstacle #1.
- If the handler leads out BEFORE the timer has indicated that they may start their run, the judge shall decide whether the infraction warrants the loss of the lead-out advantage as with a nervous new handler, or an Excusal for training in the ring.

Lead-out: Handlers often attempt to gain an advantage by placing their dogs in a stay prior to the start line and leading out on the course. The handler incurs some risk in attempting this maneuver to gain the advantage of a head start on the dog. Some of the risks include dogs that break early, dogs that start the course before the handler is ready, and dogs running out around obstacle #1. The following policies should be adhered to regarding lead-out advantage:

- Once the timer has given the handler the okay to start, handlers may lead out as many obstacles as they wish.
- A handler may touch the dog to position the dog for the start of the course and may return to the dog and reposition it nicely, without restriction, as long as neither the handler nor the dog has crossed the start line/plane.
- Once a handler crosses the plane of the start line with one foot to lead out, he or she may not touch the dog for any reason. If the handler does so, he or she shall be faulted with an "F" or "E", depending on the circumstances. (i.e. an "E" would be called if the handler returned to the dog and touched it for any reason; an "F" would be called for the handler who returned to the dog, started the course without touching the dog, and unintentional contact occurred which aided the dog's performance over the first obstacle).
- Once a handler has taken a lead-out, if the dog breaks position (without crossing the start line), the handler may go back to reposition the dog to successfully approach obstacle #1; however, the handler may not lead out again, nor may the handler touch the dog while repositioning it. The judge may tell the exhibitor when they go back that they may not lead out again.
- If a dog breaks before the handler is ready and starts the course either by

completing the first obstacle or by crossing the plane of the start obstacle, the handler may not reposition the dog at the start of the course. This is training in the ring, and the handler shall be excused.

- If the handler leads out and it is noticed before the dog starts that any or all equipment is set at the wrong height, the handler may return to the dog and may touch the dog while the equipment is set correctly. Once the ring is ready and the timer indicates that the team may go, the handler may lead out.

Stopwatch/e-timer malfunctions: Sometimes a stopwatch/e-timer or a timer's thumb will malfunction. The timer should be instructed to make sure the watch/console is running by looking at it each time a dog crosses the start line.

- If the watch/e-timer is not running, the timer shall blow the whistle or press the horn button if the handler has not completed the first 3 obstacles. Any faults incurred by the dog in the first three obstacles remain in place. Judging of the performance on the restarted course would begin on the obstacle beyond those obstacles completed when the malfunction was signaled.
- If the malfunction is discovered after the third obstacle, the timer shall not blow the whistle nor press the horn button and shall allow the dog to compete the run, notifying the judge at the end of the run. If the dog had a qualifying score based on course faults the first time through, the score will stand and the re-run procedure will be followed to determine a time (see below). For a re-run, the handler will have the option of restarting the course immediately, at the end of the jump height, or at the end of the class (if the dog is already at the end of its jump height.) If there is a videotape that shows the start and end clearly and the handler wishes to use it for determination of the dog's time, the judge may time the dog's performance on the tape, thus avoiding a rerun.
- If e-timing fails during a jump height, the Timer will use hand timing for the remainder of the height class.

Re-run for time:

- See Chapter 6 Section 2 for instructions on FAST re-runs, Chapter 7 Section 3 for instructions on Time 2 Beat re-runs, and Chapter 8 Section 3 for instructions on Premier re-runs.
- The judge must determine ahead of time whether or not the dog clearly completed the course under standard course time.
 - If it was **clear**, beyond a shadow of a doubt, that the dog was under time, the judge shall instruct the handler that the dog's time will be the *lesser* of the actual re-run time or standard course time. The judge may assign standard course time if the exhibitor does not wish to re-run or if the dog does not complete all obstacles on the course.

If the handler runs their dog in an unsafe manner, the judge will ask the handler and dog to leave the ring. Standard course time and a qualifying score will then be assigned to the dog.

- If it was **unclear** to the judge as to whether the dog completed the course under standard course time, then the judge shall instruct the handler that the re-run time will be used regardless of whether it was close to the dog's original time or not. A dog that does not complete all obstacles in this case, or a handler who runs his or her dog in an unsafe manner solely trying to get a better time, shall be given an "E" and excused. A dog shall be eliminated for fouling the ring during a re-run in this case.

Prior to a re-run for time, the handler must be briefed that:

- The dog had a qualifying score and any course faults that may have been incurred remain in place for the dog's final score.
- In order for the re-run time to count, the dog must perform all obstacles completely (including all weave poles, the entire 5 second table count in the standard class, and ascending and descending each contact obstacle). The 4-paw rule is not in effect on a re-run since the dog must perform all obstacles.
- Dogs shall not be faulted for any course faults while they are on a re-run. The dog's original score remains in place and the new time is added to the scribe sheet.
- Handlers and dog must perform the re-run in a safe manner.

Dogs jumping in the wrong height: It is the exhibitor's responsibility to know what height division the dog is jumping in at any given trial and for verifying the proper jump height is set prior to running. Dogs must compete in the height division in which they entered unless, prior to their run, a measuring official has moved them to a different height division. If a measuring official has moved them to a different height division, they must then run in the new height division to which they have been moved. If a dog runs or has been started at a wrong height (whether higher or lower) it shall be given an "E", regardless of whether the dog completed the course or not. The dog cannot be re-run in the proper jump height.

SECTION 2. Equipment Malfunction/Missing equipment

The chief course builder is responsible for ensuring that the equipment on the course is safe and is set and operating correctly. The judge shall also inspect all equipment prior to starting the class. Still, equipment will malfunction from time to time. Severe malfunctions will require you to come to a fair solution with the

exhibitor. Equipment that is wobbly or less than perfect is not considered to be severely malfunctioning; however, every attempt should be made to remedy any and all equipment problems as soon as they are discovered.

Examples of severe equipment malfunction include:

- Table and contact obstacles that fall apart when the dog is on them.
- Weave poles that break off or pop off of the base.

When a severe equipment malfunction happens, it may be possible to instruct the handler to continue on the course and deal with the problem once the dog has finished and has a score and time. For example, if a weave pole is broken, and the dog has picked up a refusal and must go back and reattempt the poles, but the pole is now lying on the ground and can't be weaved, it would be best to go on with the course. After the dog finishes the course, you would then instruct the handler (if the dog had a qualifying score other than at the malfunction) to reattempt the poles, beginning one to three obstacles prior to the poles. Judging commences with the dog's approach to the poles, and continues until the dog has exited them.

Sometimes the malfunction affects the dog or handler greatly, and the run basically stops at that point. In these cases, the equipment should be fixed, and the dog should be given an opportunity to perform it (one time) immediately, to re-acclimate itself to the obstacle prior to completing the course or the re-run as described below. If the dog had incurred faults that would keep it from qualifying prior to the severe equipment malfunction, then the handler should be allowed to simply complete the course at that time. If the dog was qualifying at the time of the severe malfunction, then the handler would be instructed that a re-run would be necessary. All faults incurred in the first run (up to the point of the malfunction) remain in effect, and judging begins at the point where the severe equipment malfunction occurred.

Exhibitors must be briefed with re-run criteria as stated in stopwatch/e-timer malfunctions.

If you determine during the running of your course that a required obstacle is missing, the ring must be halted and the required obstacle put into place immediately. Conversely, if you determine that a dummy obstacle is missing (hence an option), the ring should not be halted – the missing obstacle should be put into place between jump heights.

SECTION 3. Ring Steward Error

On occasion, a ring steward will set a piece of equipment, such as a bar,

table, or tire, incorrectly and the judge will not discover it until it is too late. The following are some guidelines as to what should be done to rectify the situation. Try never to fault or disadvantage a dog for your ring crew's error.

- A piece of equipment set too low: If the handler questions the height of an obstacle set too low while running, the judge should instruct the handler to go on and complete the course, finishing all obstacles. If the same type of obstacle, set at the correct height, was taken correctly elsewhere on the course, no further action is necessary (generally the case with bar jumps). If the course only had one of that type of obstacle (for example, a table), and the dog has a qualifying score after finishing the course, the obstacle should be set correctly, and the handler should be instructed to have the dog reattempt the obstacle (with up to a three obstacle sequence leading in to it, if the handler chooses) to demonstrate that the dog can complete the obstacle correctly.
- A piece of equipment set too high: If no error has taken place, no further action is required. If the dog has correctly taken the same type of obstacle elsewhere on course, no faults should be assessed and no reattempt is necessary, as the dog has demonstrated the ability to successfully complete the obstacle elsewhere on the course. If the obstacle that is set too high only appears once on the course and the dog has a fault at that obstacle (including a run-out or refusal), the dog should finish the course (the handler should be instructed by the judge to do so). If the dog has a qualifying score after finishing the course except for the incorrectly set obstacle, the obstacle should be set correctly, and the handler should be instructed to have the dog reattempt the obstacle (with up to a three obstacle sequence leading in to it) to demonstrate that the dog can complete the obstacle correctly. If the handler stops at the incorrectly-set obstacle (becomes lost or disoriented), losing significant time, the judge may offer a re-run if the dog was qualifying to that point. The same criteria as listed under stopwatch/e-timer malfunction would be used. If the dog was not qualifying to the point where the malfunction happened, then the handler may finish the course but no re-run is allowed.
- A-frame: If a dog faults the A-frame set at the wrong height (either too high or too low), the same action is followed as when a dog faults equipment set too high. If the A-frame is set at the wrong height but no fault is incurred, no further action is taken.

SECTION 4. Dealing With Ring Crew Problems

As the judge, you are hired by the club to judge the dogs entered in the trial and to administrate proper ring procedure. You must work with the club to ensure that the ring crew is functioning properly. It may be necessary to replace someone in his or her assigned task to ensure that the trial continues as efficiently as possible. The replacing of ring crew members should not be done without consideration for its effect on the club. Requests to reassign ring

crew personnel should be directed to the Trial Chairman or Chief Ring Steward for action.

SECTION 5. Judge's Error

Judges are human and will make errors from time to time. If a judge wishes to change a call after it has been signaled, the judge should go to the scribe at the end of the dog's run and correct the scribe sheet together with the scribe. If a judge has a change of mind or realizes that an error was made in the proper score of a dog that had run previously, the judge may make a change, as long as he or she is certain that the correction is made on the right scribe sheet for the dog whose score needs to be corrected. The judge must initial any and all changes made on a scribe sheet. Handlers may have a fault that they know occurred added to their own score after notifying the judge and the judge must initial the change on the scribe sheet.

SECTION 6. Training/Correction in the Ring

Training in the ring can happen at any time during the run, but generally happens only after the dog has incurred a non-qualifying fault. At that time, the handler knows that the dog will not qualify and makes the decision to no longer compete for the best possible score and time.

Situations after the dog has NQ'd and where the dog is being corrected for a behavior or a result, such as missing a contact or knocking a bar, should be viewed by the judge more critically. Training in the ring takes on many different forms. To explain every possible situation for which a judge should excuse a handler would be impossible; however, a few of the more common instances have been listed below.

The following are some guidelines for properly identifying training/correction in the ring that should result in an excusal:

- A handler who purposely touches their dog (with their hands) to get it to perform an obstacle or pets the dog to reinforce a behavior. If a handler asks if they can touch their dog if they are having a problem at an obstacle, you may answer that the handler may either go on to the next obstacle or ask to be excused from the ring, at which time they may hold the dog's collar as they leave the ring.
- A handler who corrects a behavior or a result they did not like through some action such as laying the dog down or making the dog sit or stop after a dropped bar or performing a contact that wasn't up to the handler's expectations. This is a punitive action, the intent of which is to tell the dog it

was wrong.

- Handlers who pick up their dogs and replace them on a contact, or direct their dogs to get back on the end of the board to reinforce a stay on the bottom. Handlers who leave their dogs on the bottom of a board after the dog has NQ'd and slowly saunter away are no longer competing, they are training in the ring, unless this was the same handling style that was exhibited while they were still qualifying.
- Handlers who purposely send their dog back one or more obstacles after making a mistake so that the dog can reattempt (sequence) the portion of the course where the error occurred again. This action is adding to the course length and time for the sole purpose of training the area where the dog had the problem. To aid in the assessment of this action, judge whether the handler is trying to get to the correct next obstacle in the fastest way possible. If they are sending the dog away from the next obstacle after the error instead of moving toward it, this may give you an idea as to whether they may be trying to reattempt a certain sequence again.
- A handler who replaces a dog on the start line after the dog broke early and started the course by passing the plane of the first obstacle.

The following are actions that may look like training in the ring but do not result in an excusal:

- A handler who checks out his or her dog after it has fallen off something to ensure the dog is not injured. This act should result in an "F", but not an excusal.
- The simple act of laying a dog down on the course is not training or correcting in the ring. You must judge why the handler is laying the dog down. Situations such as a U-shaped tunnel under a contact can be confusing for a dog that only has eyes for the tunnel, yet the course flow requires the contact to be taken next. In this case, the handler lies the dog down to refocus it and break the tunnel fixation. This is not excusable training in the ring, for the handler is trying to get the dog onto the contact obstacle, which must be performed as the next obstacle prior to going on.
- If a dog has a runout or committed a wrong course, the handler should be getting the dog back to the proper obstacle as quickly as possible. A dog that does an obstacle or two on the way back to the next proper obstacle (including any of the preceding obstacles prior to the mistake), whether directed to or not by the handler, is simply finding the fastest way to continue on, and should not be excused.
- If a dog breaks its position at the start line without crossing the plane of the first obstacle but the handler has already crossed the plane of the first obstacle, the handler may go back to the dog, but must leave with it and start the course expeditiously. If the behavior troubles you, verbalize what you want the handler to be doing. If the handler does not comply, excuse him or her for

failing to comply with your verbal instructions.

If there are instances where you believe the handler is getting close to being called for training/correcting in the ring, you may warn the handler by telling him or her what to do, such as by saying “go on to the next obstacle now”. If the handler fails to comply, excuse the handler for failing to comply with the judge’s verbal instructions based upon the behavior you judge as being corrective or training.

Harsh or angry corrective commands should always result in an excusal, regardless of whether it is training in the ring or not.

Training in the ring is an excusal (“E”). The judge shall blow the whistle, and the dog and handler must be excused from the ring and leave expeditiously. If the situation warrants it, the judge should consider discussing the infraction with the exhibitor in the ring, with the length and tone of the discussion gauged to the seriousness of the infraction. If an exhibitor refuses to leave the ring after the judge has blown the whistle and informed the exhibitor they are excused, the exhibitor may be held to an Event Hearing based upon but not limited to Unsportsmanlike Conduct during an event.

SECTION 7. Correct Run-off Procedure for Tied Scores

Run-offs should be held only if two dogs in the same class and same jump height are tied with exactly the same score and time (to the 100th of a second) for a placement of 1st through 4th. If one of the handlers is unwilling to participate in the runoff, the higher placement will go to the other handler and dog. If neither handler wants to participate in a run-off, the placement can be decided in a mutually agreeable way, such as a coin flip. Run-offs shall comply with the following:

- The run-off should be held preferably on the same course just completed by both dogs, or, alternately, on an easier course (e.g. a tie in Excellent can be run off on an Open or Novice level course). If the tie was in a lower class level and a higher level course is the only one available, a portion of the more difficult course may be used for the run-off.
- The run-off course must be of the same type of course that the two dogs originally tied on (e.g. if they tied on a JWW course, then they must be run off on a JWW course).
- The course shall be measured and a standard course time announced if a previously measured course is not being used.
- The course shall be judged and scored as in the standard rules for that class. All errors shall be signaled and recorded on a new scribe sheet marked “run-off” (so it’s not confused at a later date), and the dog’s running time will be

recorded.

- The dog with the fewest faults wins the runoff. For scoring purposes, all faults are converted to a numerical basis; regardless of class level, refusals, wrong courses, and table faults are five faults each; an “F” or an “E” is a 100-point fault. If both dogs have the same numerical score, the dog with the fastest time wins.
- Regardless of the final score of the run-off, both dogs receive the scores and times from their original runs, with both dogs qualifying and the winner of the run-off placing higher in the class. It must be recorded in the catalog that the higher-placing dog was the winner of the run-off.

SECTION 8. Weather-Related Problems

Trials held outdoors are subject to many different weather-related issues. The judge is often looked on to help the trial committee in making decisions on how to deal with weather-related issues; however, final decisions relating to canceling any trial or classes is ultimately the Trial Committee’s decision. When dealing with weather conditions, you must be aware that classes or portions of a class **must not be moved from one day to another, since each day is considered a separate trial.** Your decision to delay a class for any reason must take into account those exhibitors who will be driving or flying home and their need to finish in time to get on the road. Additionally, required equipment for the class level may not be removed from the course based on weather conditions.

If you decide to take a break to let the weather clear up, it is wise to break at a jump height change or class change. All dogs within a jump height or class cannot be guaranteed the same weather conditions; therefore, it is possible that some dogs may be affected by adverse weather while others in the same class may not. There is nothing that can be done about this, and no dog shall receive a rerun based on weather. The decision to run or not to run is always the handler’s. In situations where the weather is extremely poor, the exhibitors should be briefed that the decision regarding whether to run or not lies with them. The following are some issues that may arise and the actions the judge should take:

Rain: Generally, agility trials proceed when it’s raining. Sometimes, however, the rain is so severe that it may be wise to hold up for a while if you think you can wait it out and the conditions will improve in time for you to finish without excessive delay.

Lightning: When thunderstorms are present and lightning has been spotted, runs must be suspended so the judge, crew, and exhibitors can take cover to the maximum extent feasible. Remember to always err on the side of safety. Resume

judging after the lightning has passed.

Snow and sleet: It is possible to run in some snow and sleet conditions; however, it can get difficult, and there must be an adequate ring crew to clear the contacts. If the equipment cannot be made safe, the judge should advise the trial committee that the trial should be suspended until conditions improve, or the trial may need to be cancelled.

High winds: Areas of the country subject to high winds can cause problems with bars and planks blowing off jumps and dogs having trouble staying on the dog walk. Windy conditions can last all day, so you will likely need to fashion solutions to allow the trial to go on. It is up to exhibitors as to whether they wish to run or not. Bars and planks can have rubber bands added loosely around them at the cup location to keep them from being blown off, as long as the bars and planks are still displaceable. If wind conditions merit, the panel jump may be replaced with a bar jump.

SECTION 9. Misconduct Hearings

The judge is not involved with a misconduct hearing unless as a witness or complainant. Judges should advise the club to follow the current “Dealing with Misconduct” booklet published by the AKC (which is sent to every trial secretary prior to the trial). If asked for advice, direct the trial committee to closely follow the Procedural Checklist, which is imperative to correctly hold a misconduct hearing. They may also recommend they contact the Director of Agility or one of the Agility Field Representatives for guidance. The timing of misconduct hearings (involving the judge) should not take the judge away from his or her judging duties causing significant delays. The judge is not to help conduct the hearing, and the judge shall only be present if he or she is testifying in the hearing.

SECTION 10. Dealing with Exhibitor Discontent

Exhibitors may wish to discuss their scores or a specific call that was made by the judge. You should discuss any call or score with an exhibitor. You should discontinue any conversation that turns harsh or abusive (see Misconduct Hearings in “Dealing with Misconduct”, Section IV). The discussion of any call or score should not significantly delay the class or trial. Judges should employ good time-management skills when discussing things with exhibitors so as not to delay a trial, while still listening to the exhibitor and investigating any perceived errors in scribing or scoring. If the exhibitor believes that an error was made, it is wise to have the exhibitor bring it to your attention at a jump height change. At this point, you may still remember the run or the call, so that it may be explained or corrected, as the case may be.

Sometimes the error, or what the exhibitor believes to be an error, is discovered much later, and the judge has no recollection of the run or the specific item the exhibitor is questioning. In this case, do your best to account for the call, although this may be impossible. Make sure the correct scribe sheet was used by checking the scribe sheets of the dogs that ran before and after the dog in question to make sure that the scribe was not off by one sheet.

SECTION 11. MACH/PACH Victory Runs and Trial Pictures

Exhibitors completing a MACH/PACH title may stay in the ring and complete a “victory lap” if they wish to do so. The victory lap must be taken immediately after the completion of the successful MACH/PACH run and before the handler and dog leave the ring. Whenever a dog and handler are in the ring, they must abide by all agility regulations and guidelines and thus are subject to the possibility of incurring an Excusal (E) fault such as fouling the ring, leaving off leash, etc.

Exhibitors who wish to pose their dog in front of or on equipment for a commemorative photo may do so between or after classes as long as it does not delay the trial or present a safety issue.

CHAPTER 10

JUDGE'S DUTIES AFTER JUDGING

SECTION 1. Responsibility to the Host Club:

Judges may not leave the trial prior to judging all dogs scheduled, as well as verifying and signing that day's marked catalog results that will be sent to the AKC. Judges have committed to judging all dogs assigned when hired. They may not let another judge finish out the class in an attempt to catch a flight or for any reason other than an emergency. Any change to the judging schedule must be indicated in the judge's and host club's reports of the agility trial to both the AKC and the Director of Agility, including the reason for the emergency that caused the necessary change.

Judges should have the receipts for any reimbursable expenses (previously agreed expenses that the club will pay for) ready to submit to the host club on the last day of judging. Receipts should be organized so that the club can provide reimbursement in a timely manner.

Judges should personally thank the ring crew. This is especially important since ring crew members are volunteers and give of their time freely. It takes many people to complete a trial successfully. A thank-you or handshake from the judge goes a long way towards the goodwill necessary to ensure agility trials will continue to have workers in the future.

SECTION 2. Responsibility to the Exhibitors

Scores should be posted for exhibitors at the trial site with each dog's actual running time to the 100th of a second (even for "NQ"s). These results should be posted either **at the completion of each jump height**, or at a minimum, at **the immediate conclusion of each class**, marked as "Unofficial" until such time that the judge has reviewed the scribe sheets and released the ribbons. Judges are responsible for seeing that awards are correct before any are given out. **At a minimum**, a judge must review all qualifying scribe sheets, plus quickly look through the NQ/ABS pile in case any Qs have been incorrectly scored, prior to the ribbons being released. It is recommended this process be done between jump height groups if there are split walk-throughs.

Judges should make themselves available to exhibitors who have questions regarding their scores. Judges can provide any details they remember of the run in question, but under no circumstances may they review videotape for scoring purposes or even to see something unofficially. The only circumstances under

which a videotape can be used is to get a time when the timer malfunctions on a qualifying run, or to check the order in which dogs ran if it is suspected that the wrong scribe sheets were used. (Regs, Ch 1, Sec 31)

Judges should make themselves available to the maximum extent possible for pictures so long as it does not delay other classes.

SECTION 3. Responsibility to the AKC:

Scribe sheets must be kept by the judge of record for a period of one year from the date of the trial. This will ensure that exhibitors are credited with their qualifying scores in case there is a discrepancy or the marked AKC catalog is misplaced.

Checking the official AKC catalog

It is the judge's responsibility to ensure that all scores are accurately recorded in the catalog that will be sent to the AKC. The judge, by his or her signature, is certifying that what is written in the official AKC catalog is correct. All the effort put into the course design, proper judging calls, signals, and everyone doing their job correctly is all for naught if the official catalog is incorrect and exhibitors do not receive the scores they earned. It is important to check scribe sheets against the official catalog after each class judged and, in some cases, between jump heights for large classes with multiple walkthroughs. The following is a list of what must be reviewed:

Scribe Sheets

Reviewing **Standard and JWW** scribe sheets:

- Verify the correct SCT was used based on the yards and SCT calculations provided by the judge to the score table (Do Not simply hand the table yards; you must calculate the SCTs separately!)
- Verify that the dog's run time did not exceed SCT – else, verify that the proper number of time fault points were deducted (if allowed for this class and level).
- Review the course faults issued during the run:
 - Are the type and/or number of course faults allowable for this class and level, else NQ
 - If allowable, have the proper number of points been deducted.
- Verify the score, subtracting both time and course faults from 100.
 - Verify the dog earned a high enough score to qualify in this class level.
- Verify the placements for each class, division and jump height

Reviewing **Premier STD and JWW** scribe sheets:

- Premier courses are not wheeled for time, thus no SCT (SCTs are fixed values) nor time faults
- Verify that the dog's run time did not **equal** or exceed MCT for the jump height entered - NQ
- Review the course faults issued during the run – any course faults result in an NQ
- Verify the score (100) is listed on all dogs who qualified
- Verify the placements for each class, division and jump height

Reviewing **FAST** scribe sheets:

- Verify that the dog obtained the Send Bonus
 - If not, **STOP!** - there is no reason to check further, nor should the scribe sheet be scored!
- Verify that the dog's run time did not exceed SCT – else, verify that the proper number of time fault points were deducted.
- Add up the **UNCIRCLED** obstacle values and arrive at a total.
- Verify the score, subtracting the uncircled value total from 80 and then subtracting any time faults.
 - Verify the dog earned enough points to qualify in this class level.
- This is the FAST “Subtraction Method” – this scribe sheet format is now mandatory
- Verify the placements for each class, division and jump height

Reviewing **Time 2 Beat** scribe sheets:

- Verify that the dog's run time did not **equal** or exceed MCT for the jump height entered - NQ
- Review the course faults issued during the run – any course faults result in an NQ
- No dog should have a score listed in the catalog; just a time, to the 1/100th (if they Q'd)
- T2B points should not be listed in the marked catalog, but may be on the Posted Scores report
- Only one dog should be awarded 1st place – no other placements should be awarded/listed
- If multiple dogs have the same time for 1st place, a run-off will determine 1st place
- SCT recorded for an exhibitor in lieu of a re-run in T2B is MCT minus 1 full second.

Marked Catalog

Chapter 1, Section 26 of the *Regulations for Agility Trials* covers the requirements for scorekeeping, including how the marked official catalog should be produced.

In the header for each **height division** of **each class**, the following information must appear:

- Number of entries (number of entries at closing **less the number of entries withdrawn**)
 - Number competing in the class
 - Number of qualifying scores
 - Number of withdrawals
 - Course yardage (except FAST and T2B and Premier)
 - Standard Course Time (except for Premier)

“Q”, “NQ”, “ABS”, “EXC”, “DQ”, “AIS” or “AJC” should be recorded next to each dog listed in the catalog – no dog should be left blank or “Not Scored”. The words may be spelled out (example: Qualified)

STD/JWW/FAST/PREMIER

___If “Q”, the dog’s score and actual running time (to the 100th of a second) shall also be recorded. Additionally, if the dog places 1st through 4th in its height class the placement shall be recorded.

T2B

___If “Q”, the dog’s actual running time (to the 100th of a second) shall also be recorded. Additionally, if the dog places 1st in its height class the placement shall be recorded.

Score and points should not be in the marked catalog, nor should there be any placements other than 1st.

ALL CLASSES

___If “NQ”, “ABS”, “EXC”, “DQ”, “AIS” or “AJC” is recorded, then NO time or score is recorded in the catalog.

- "AIS/AJC" - Withdrawal (bitch in season/judge change). No other reasons are valid / to be used.
 - AIS stands for Absent–In Season / AJC stands for Absent – Judge Change
- “EXC” The judge should *EXCUSE from the ring* any dog that displays menacing or threatening behavior.
- “DQ” The judge should *DISQUALIFY from the ring* any dog that attacks any person in the ring. This means the dog is barred from competition for life unless reinstated by AKC’s Board of Directors.

All catalog pages must be initialed at the bottom right by the judge of record for that page’s class, level, and jump height. All marked catalogs must be generated in one-to-a-page format.

The judge must be provided their copy of the marked catalog prior to

leaving the show site **each day**.

It is permissible for the TS to provide the judge's copy of the marked catalog electronically, but the judge must verify delivery before leaving the show grounds each day.

PLEASE don't arbitrarily sign the certification page; have some method in place to keep track of your Q counts throughout the day, so that you can verify the numbers listed in your certification paragraph!

Separate certification paragraphs for each judge of record are required in the catalog.

Other notes regarding the marked catalog:

- If the SCT and yardage needs to be corrected in the catalog, request that the catalog page for the entire class/jump height be regenerated as Qs may be affected by the correction.
- Any dog that has been excused or disqualified must be reported on the proper form (provided by the host club) to the AKC Records Department, and a full report shall be included in the judge's post-trial report to the Director of Agility.
- Titles, breeder, sire or dam are not required to be listed in the marked catalog.
- Mixed breeds enrolled in the AKC's Canine Partners program should be listed in the catalog results as "All American."
- Judges must initial the bottom of pages they are reviewing to ensure that these pages are the actual ones used in the official catalog, since with computer scoring each sheet is loose and needs to be bound at a later time. Judges must NOT initial any page containing results for which they were not responsible or for dogs they did not judge. If there are mixed results on a page, judges must cross out those results for which they were not responsible.
- It is perfectly acceptable to make a correction by pen, but be sure to initial the changes and ensure that the incorrect version is not retained by the scoring table. Simply drawing an X across the incorrect page will make it stand out
- Judges must have their copy of that day's marked catalog results before they leave the show site each day. The club must not send it to them later. It is suggested the club prepare three catalogs at the same time, with the AKC catalog being the most important.
- It is permissible for the Trial Secretary to provide your judge's copy of the marked catalog results by electronic media so long as you are able to verify its delivery prior to leaving the show site each day. For example, if delivery is by PDF file to a USB drive, be sure to access that USB drive to verify the

file exists. If by email attachment, you must access your email account to verify delivery prior to leaving the show site.

- The AKC requires that a separate catalog be submitted for each day.
- If a tie for placements exists, along with double-checking that the winner of the tie received the higher placement, note in the marked catalog results how the tie was resolved (run off, flip of coin, etc.)
- If a handler wishes to refuse a qualifying score, it is acceptable for the judge to change a score to an NQ by recording an “E” (Excusal) on the scribe sheet and noting the reason given by the handler.

CHAPTER 11

FOR EXHIBITION ONLY AND FIX N GO ON

For Exhibition Only (FEO) and Fix n Go On are pilot programs for 2020. The AKC agility staff will evaluate their impact during the year.

SECTION 1. For Exhibition Only (FEO)

FEO will be offered at the option of the host club. Premium lists must state whether FEO will be offered or not. FEO is only allowed in the T2B and FAST classes, and exhibitors must be entered in the class to participate. FEO allows exhibitors to train in the ring with their dogs. It will be of value to new exhibitors and exhibitors who are having difficulty with a specific obstacle and/or the ring environment. Participation in FEO is non-qualifying.

- FEO runs are treated as trial entries. The exhibitor must enter the class (T2B and/or FAST) prior to the closing date, pay class entry fees, and the Trial Secretary must record the entry in the Trial Catalog as part of the results for that class.
- Dogs may be entered at any height for FEO runs. Day of show height changes are not allowed. If not eligible for the entered height, the team is committed to FEO for that run and must declare FEO on the start line.
- Dogs may be entered in any level of FAST for FEO. Day of show level changes are not allowed. If not eligible for the level entered, the team is committed to FEO for that run and must declare FEO on the start line.
- The exhibitor must declare FEO in the ring prior to leading out or starting their run (whichever comes first). It is recommended that exhibitors mark or have the Gate Steward mark FEO on the gate sheet as a courtesy to other exhibitors, but it is not required; the handler has up until they lead out or start the course to opt for FEO.
- The Judge will verbally confirm FEO to the scribe. The scribe will record FEO, NT and E on the scribe sheet.
- Toys are allowed in the ring
 - Toys must be non-audible
 - Toys may not leave the handler's hand
 - Toys that roll freely cannot be used
- Food/treats are not allowed in the ring.
- The team may move into the body of the course to work any location, but the leash must be left in usual start area.
- Handlers can touch equipment and may touch/pet their dogs during an FEO run.

- Timer will start the time manually when one of the following happens:
 - handler moves away from the dog in any direction
 - dog moves away from the handler
 - handler and dog move into the course area (including handler carrying dog)
- FEO Course Time
 - T2B when horn goes off at MCT the handler must proceed to the out gate
 - FAST when the first horn sounds the handler must proceed to the out gate
- FEO should be utilized for the benefit of the dog and not as a punitive correction. Harsh verbal and /or physical corrections shall not be tolerated. Any determination of harshness by the judge shall be immediately whistled and the handler will be dismissed from the ring.
- A judge must monitor the entire run. Judges can stop a run at any time they deem necessary.
- Judges will be asked to provide entry counts of FAST and T2B FEO runs on their post-trial report during this pilot period.
- AKC Agility Field Reps, Director and their family members may enter their dogs in FAST and T2B as FEO runs.

SECTION 2. Fix N Go On

Fix N Go On allows exhibitors to immediately reattempt an obstacle or short sequence one time on course when the dog's performance is not to their expectation. They may make one reattempt. This allows the dog a chance to successfully complete the obstacle or sequence and finish the course or leave the ring on a positive note. Using the Fix N Go On option will result in a non-qualifying score. Once the handler initiates Fix N Go On, the judge will signal with crossed arms to the Timer and Scribe. The Scribe will then write a circled X on the scribe sheet, which is the scoring equivalent of E and NT, except that the team does not immediately have to exit the ring. The Timer will watch the timer console and immediately press the horn or blow a whistle when the following times are reached:

- 60 seconds for STD
- 45 seconds for JWW
- T2B MCT (horn will automatically sound)
- FAST at the first horn (horn will automatically sound)

At the horn/buzzer/whistle, the handler must expeditiously proceed to the finish/exit. If a Fix N Go On has been initiated and the buzzer sounds, the

exhibitor may complete the Fix N Go On before proceeding to the finish/exit.

- After a Fix N Go On, the judge will no longer signal faults but must stay engaged with the team.
- Handlers may opt to reset the dog and repeat an obstacle one time to attempt to fix a behavior that does not meet their expectations. Handlers may include one or more preceding obstacles to establish an approach to the obstacle being fixed.
- Handlers may take a second lead-out as their Fix N Go On.
- Handlers may touch equipment, touch/pet their dogs, and reset any one jump.
- Should a handler attempt a second fix at that point or later in the course, the judge will blow the whistle, and the team must exit the ring.
- Fix N Go On should be utilized for the benefit of the dog to reinforce correct performance and not as a punitive correction. Harsh verbal and/or physical corrections shall not be tolerated. Any determination of harshness by the judge shall be immediately whistled and the handler will be dismissed from the ring.

APPENDIX

DIAGRAMS AND ILLUSTRATIONS

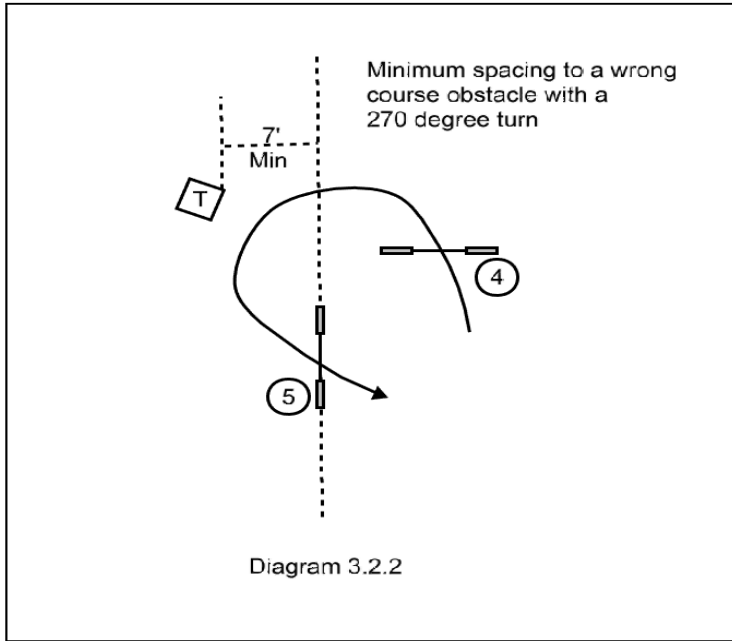

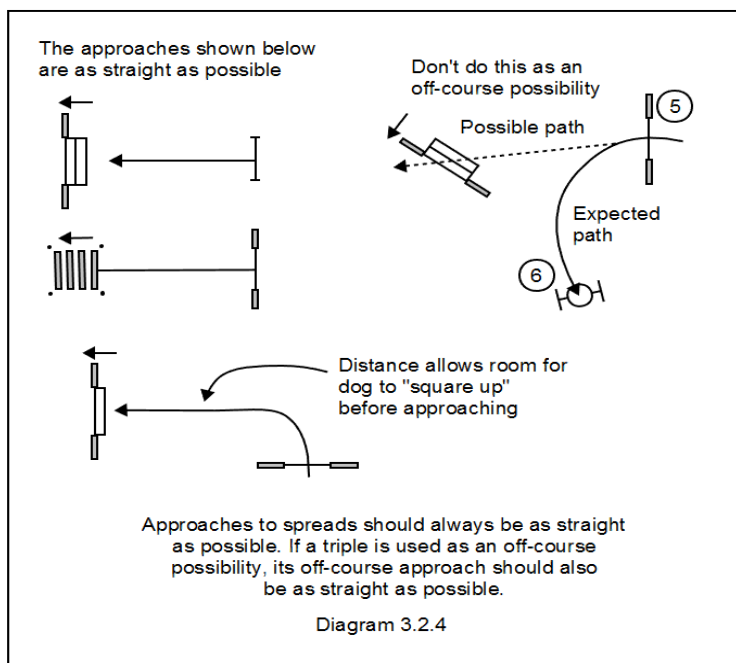
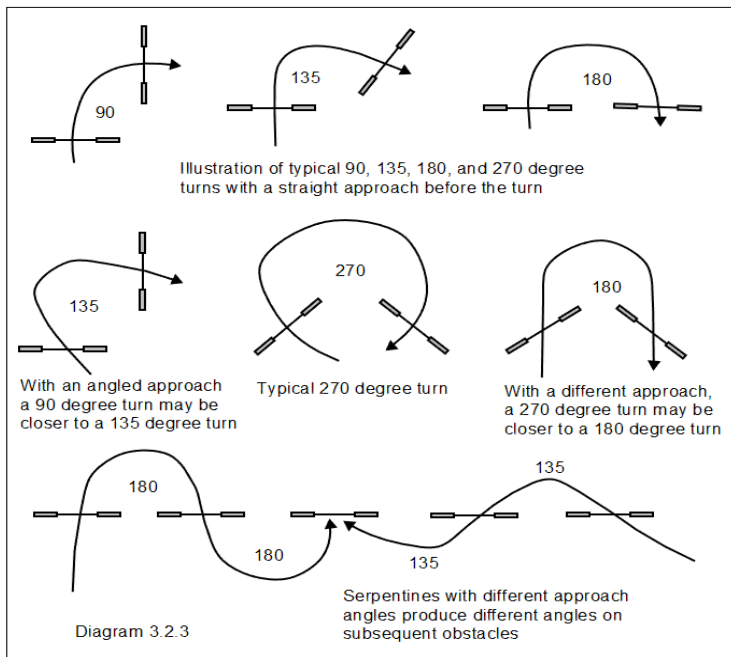

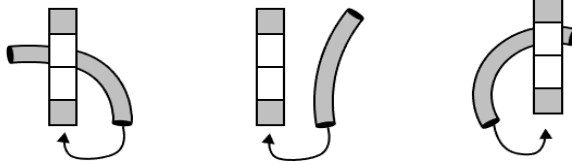

A turn from a tunnel under or adjacent to the A-frame to the ascent ramp of the A-frame is not allowed

Diagram 3.2.5

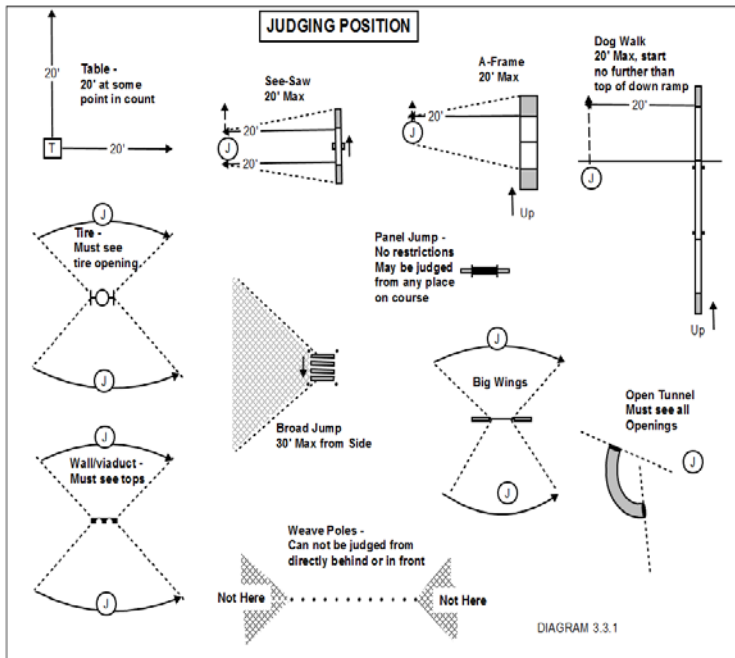

This JP would NOT be approved for judging the dogwalk contact

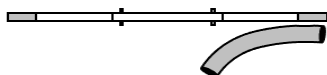

Obstacles may not block the judge from stepping in (weave poles shown), and may not obstruct your view of any part of the contact zone (tunnel shown).

Diagram 3.3.2

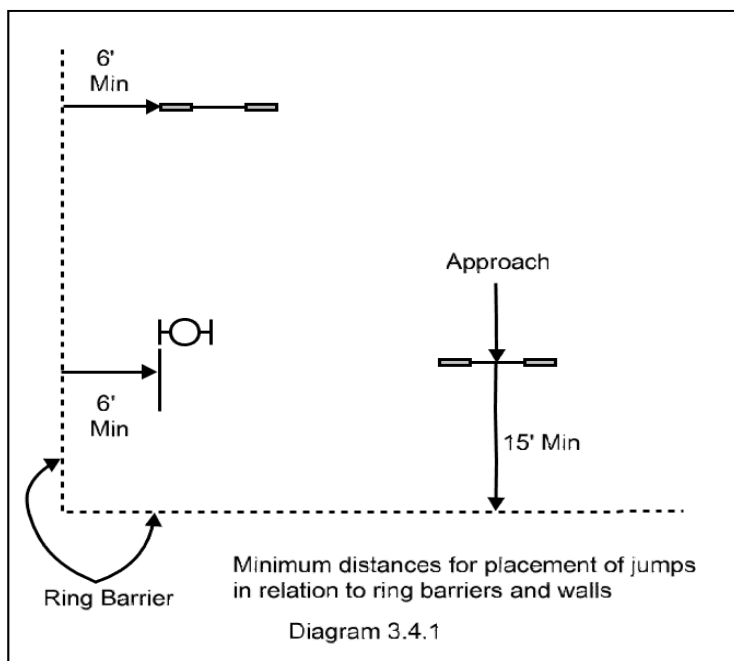
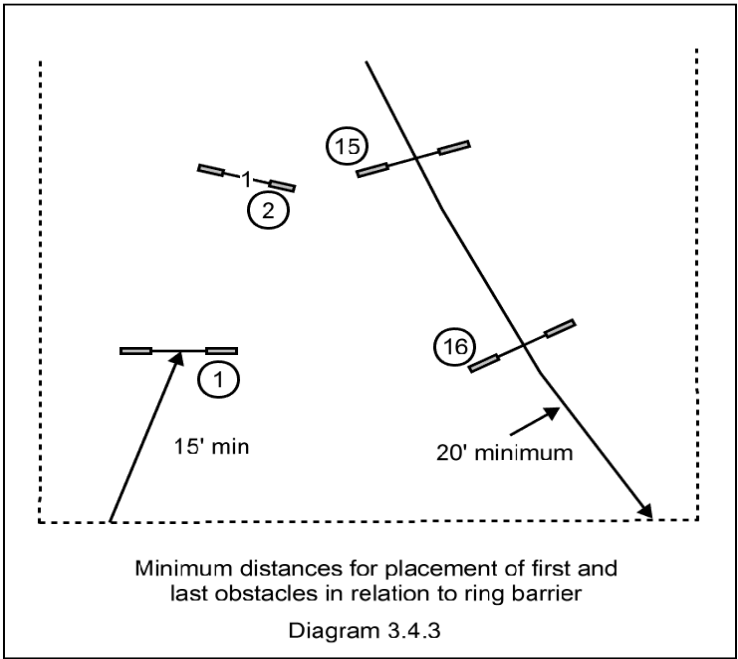
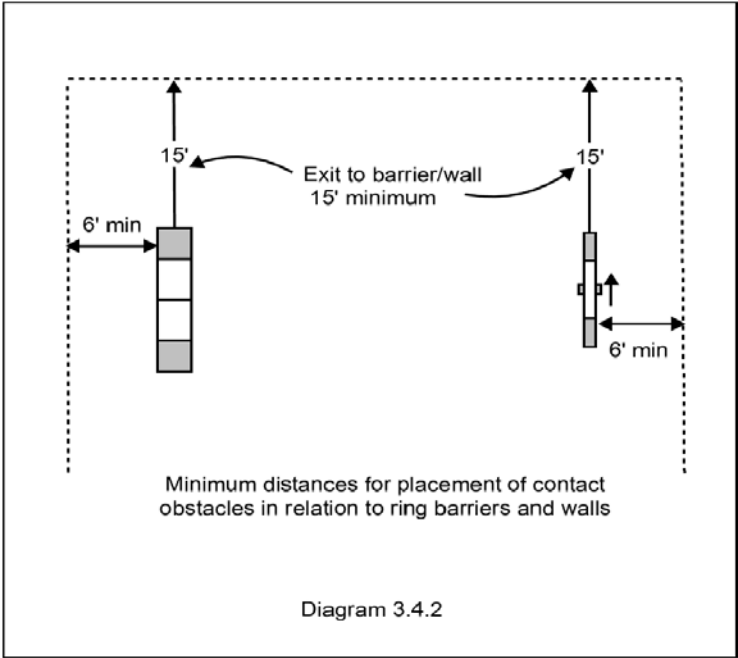
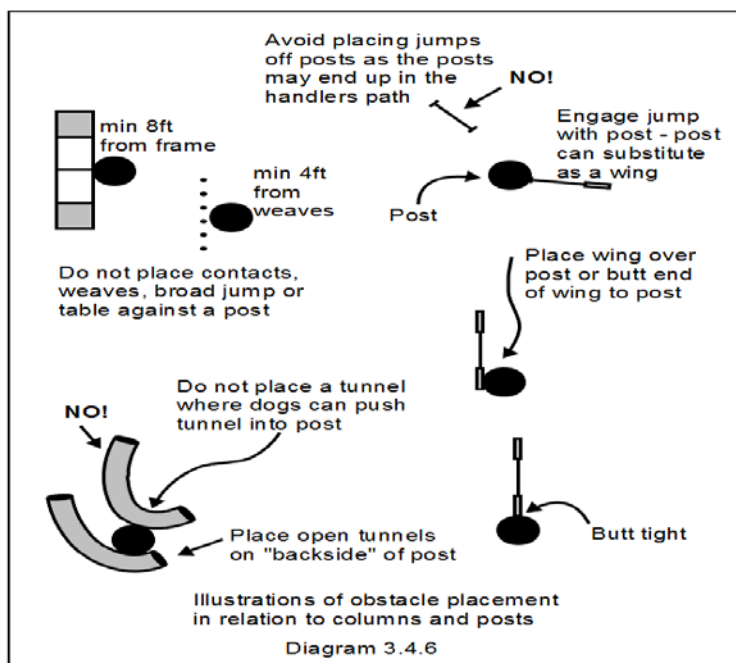
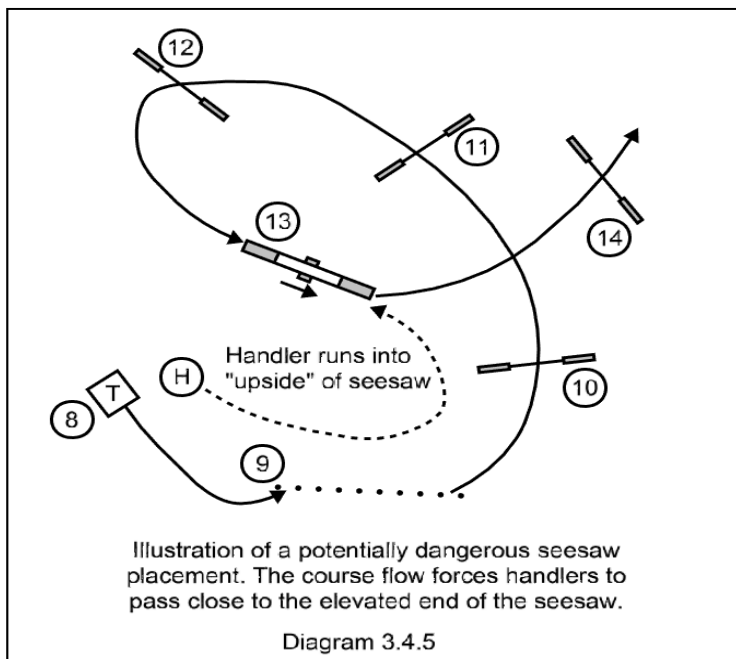
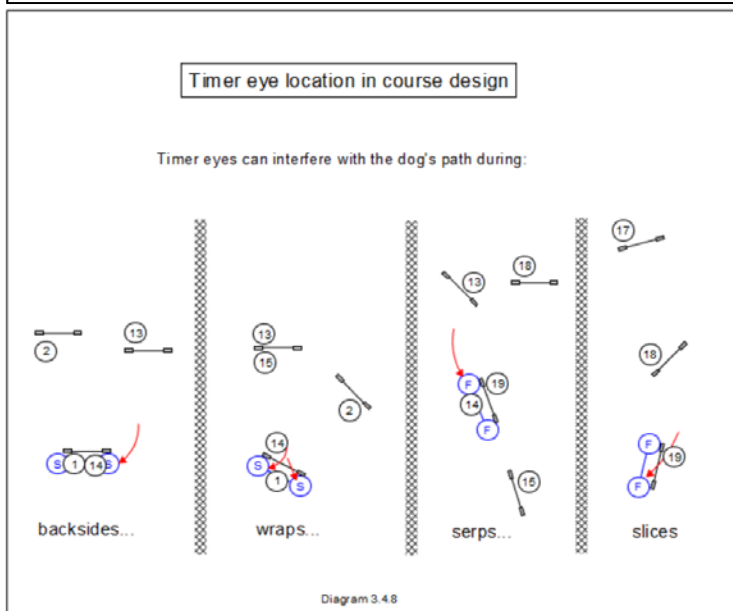
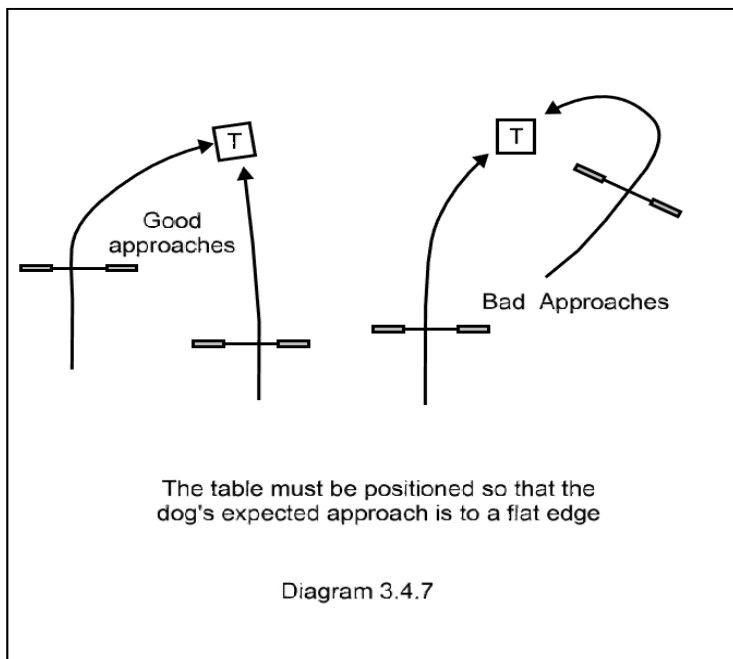
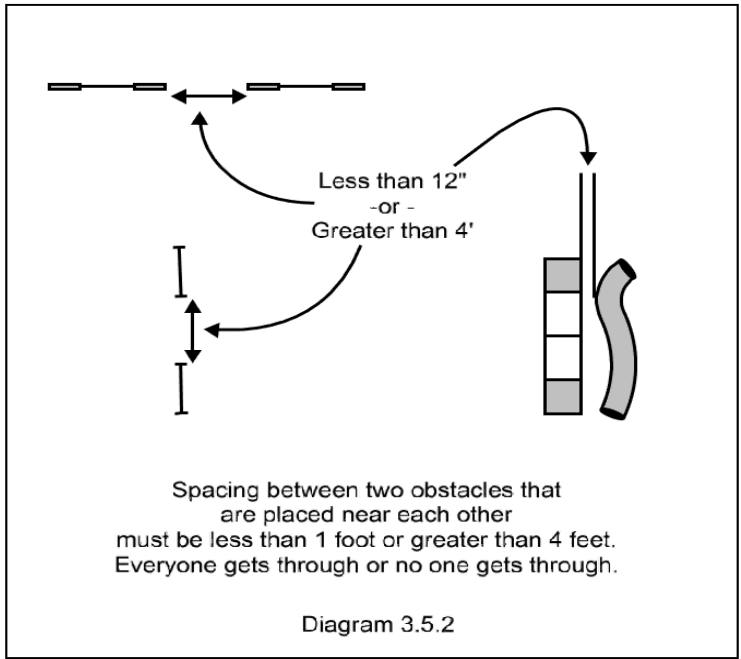
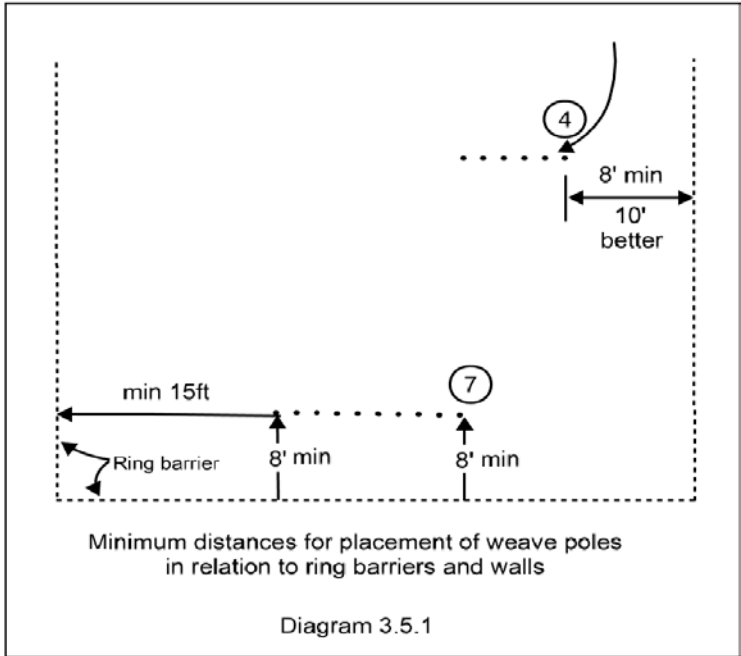

Diagram 3.4.1









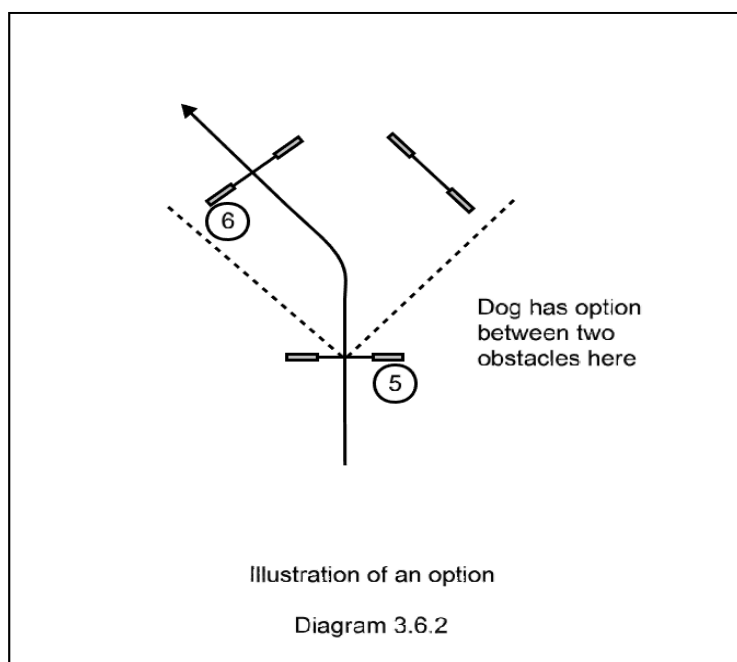
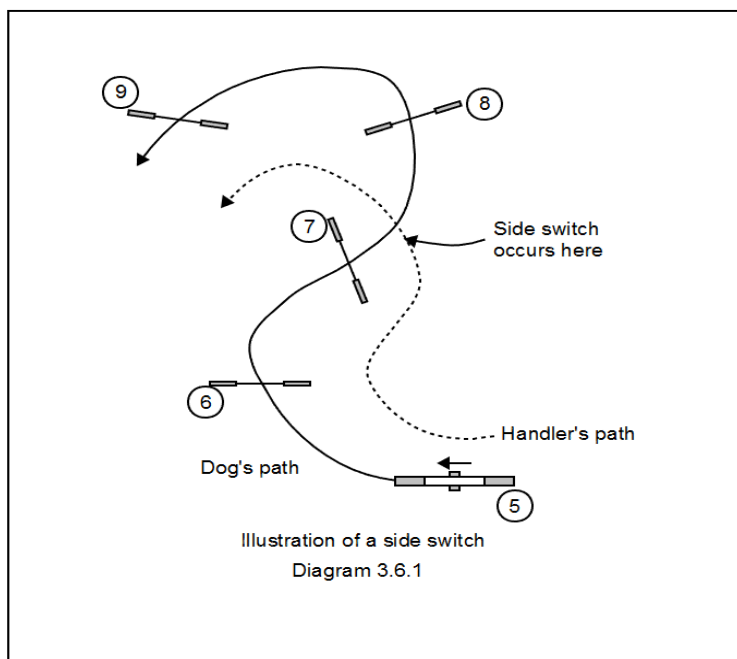

Exception to 21ft
max for options

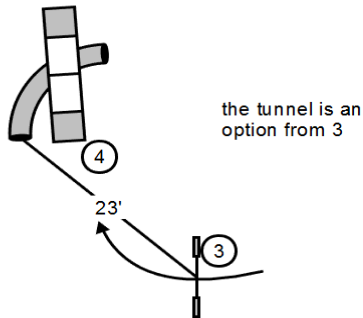

Diagram 3.6.3

Weave poles are counted as an option if the entrance or exit is in range and the dog's path is on the approach side of the run-out plane.

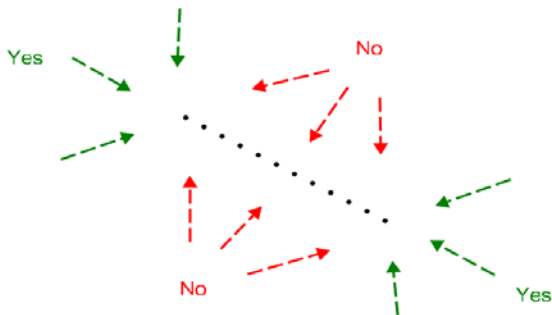

Diagram 3.6.4

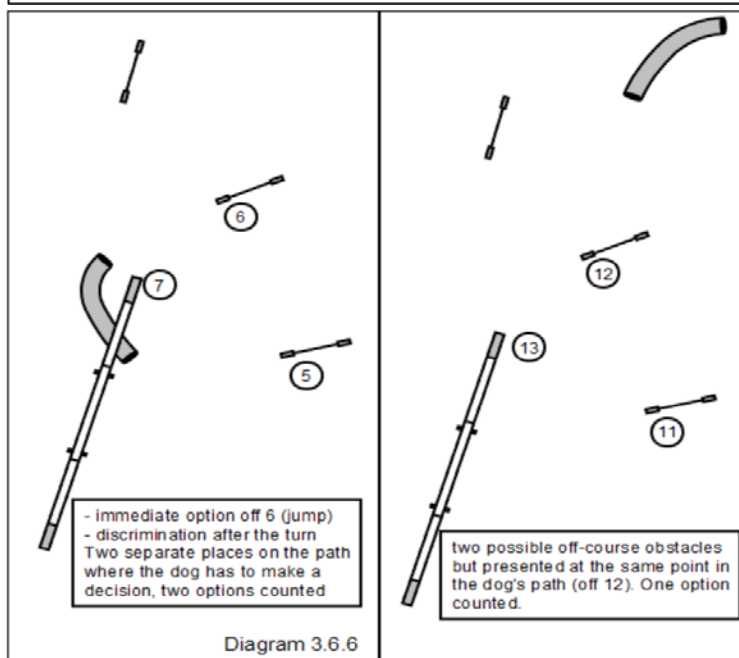
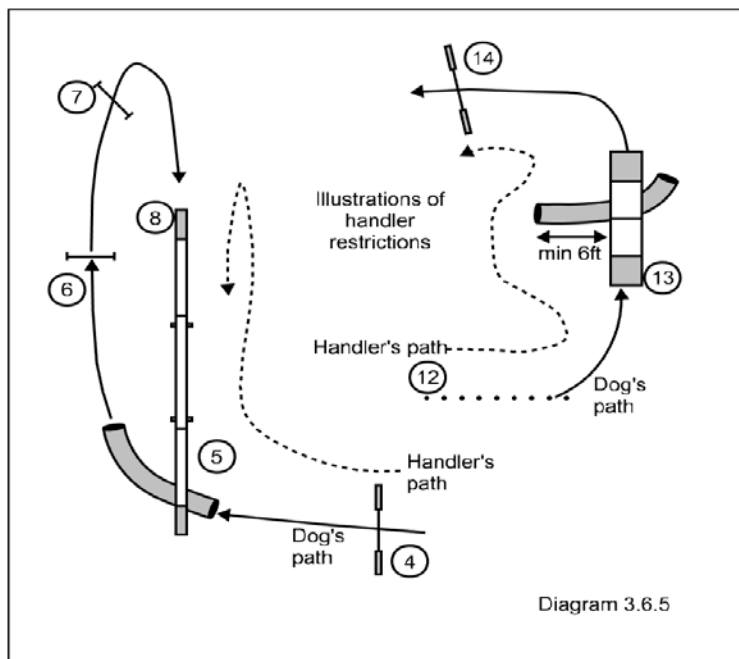

Illustration of course design that will result in problems during course judging with judge being trapped behind dog and handler since judge should not cross in front of a working dog's path.

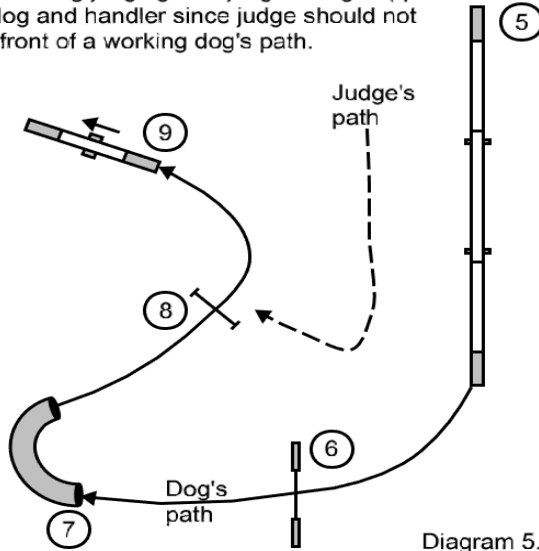

Diagram 5.1.1

Diagram 5.1.2

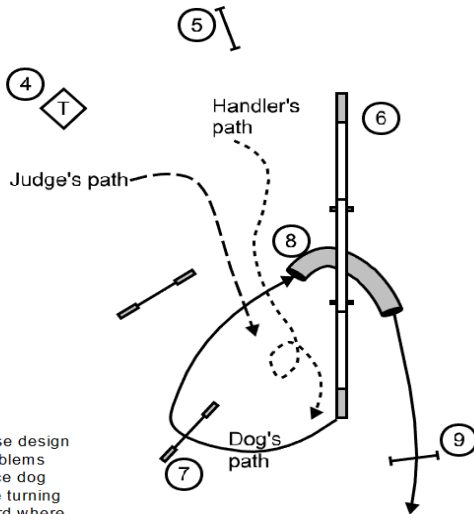
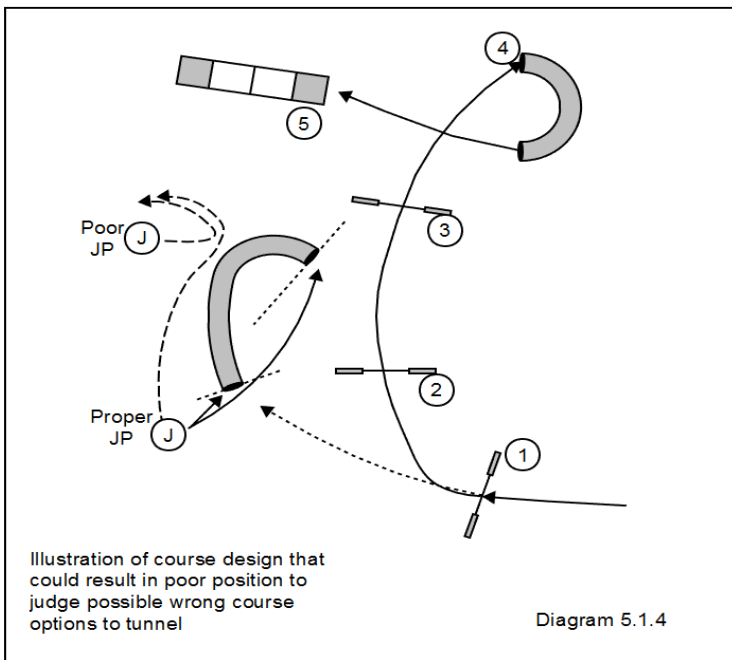
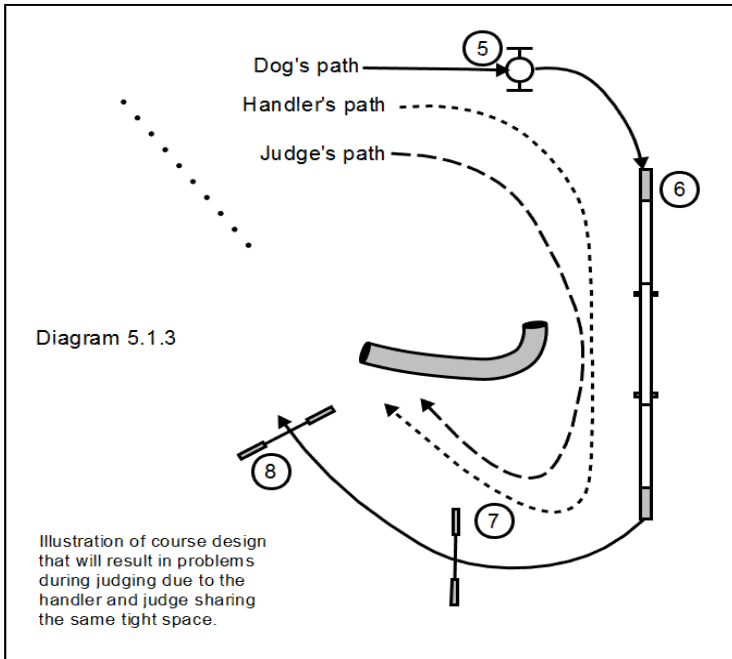
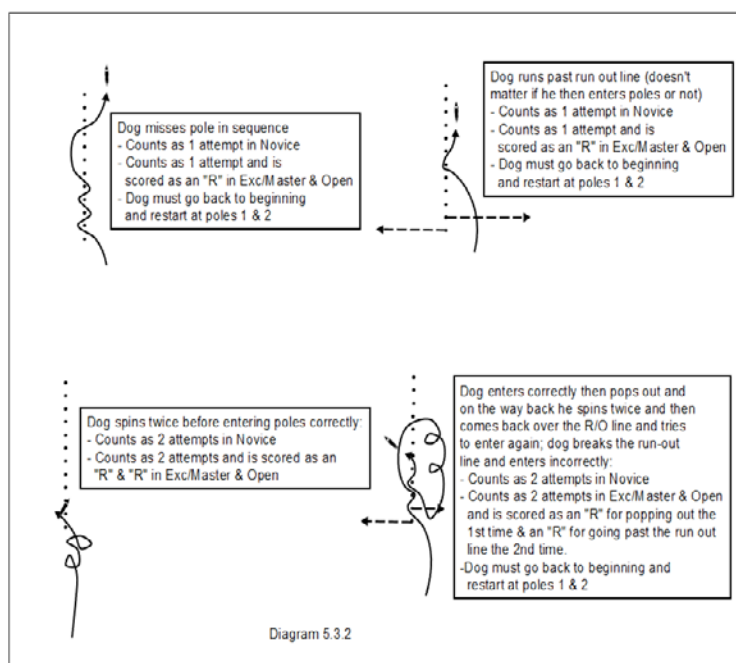
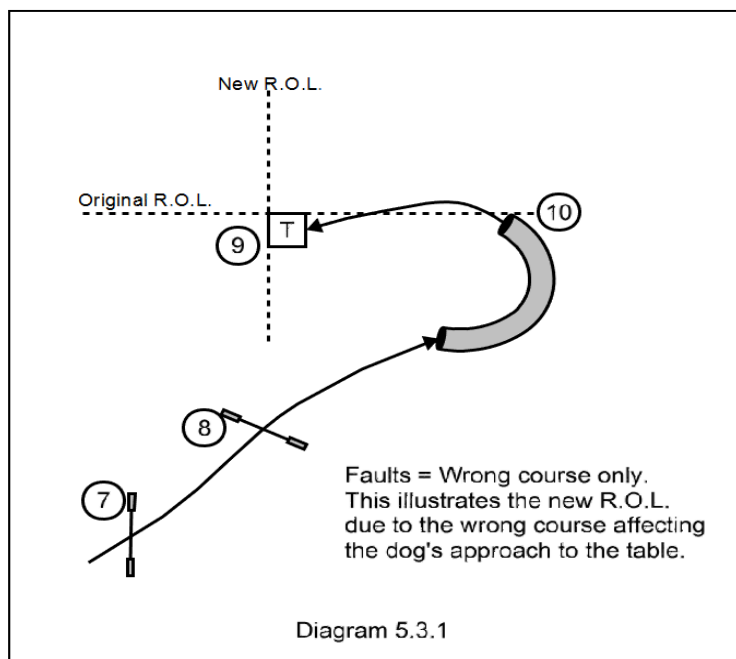
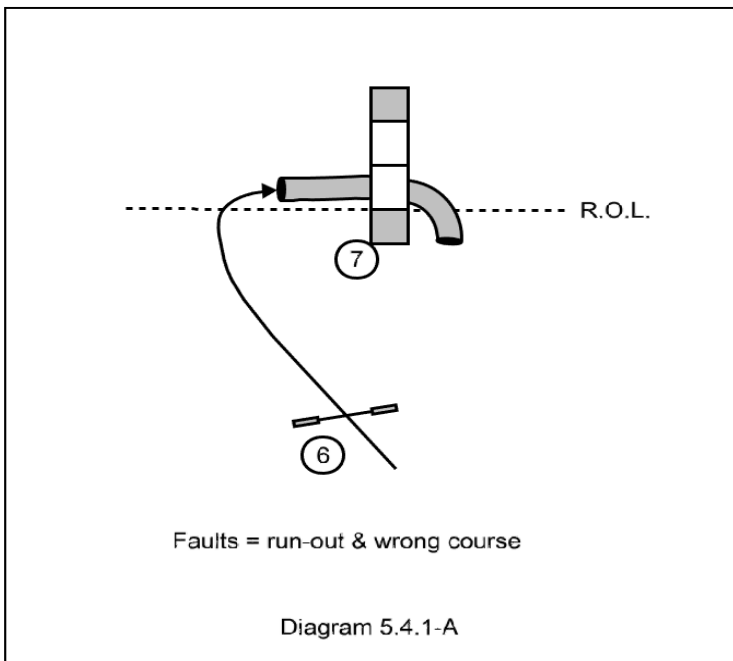
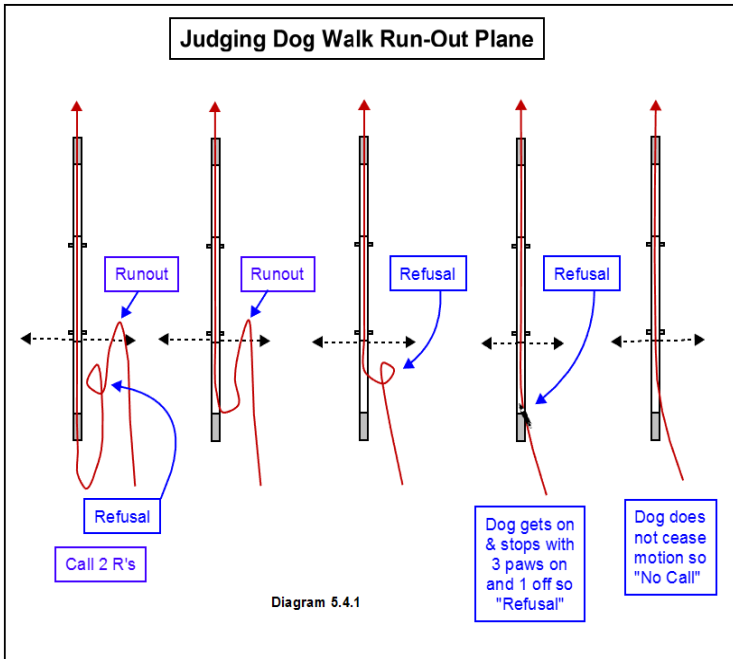
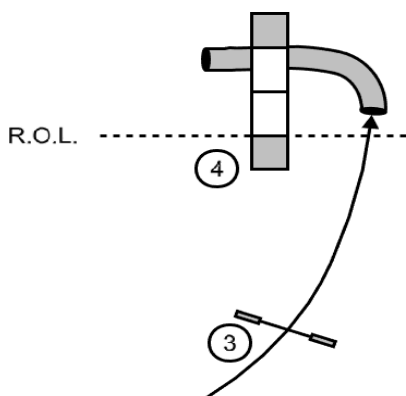

Illustration of course design that will create problems during judging since dog and handler will be turning sharply back toward where the judge must be to properly judge the contact zone.









Faults = run-out & wrong course

Diagram 5.4.1-B

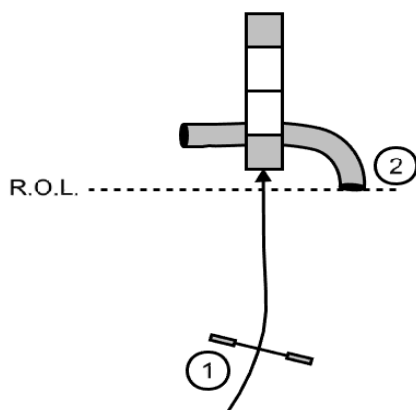

Faults = run-out & wrong course

Diagram 5.4.1-C

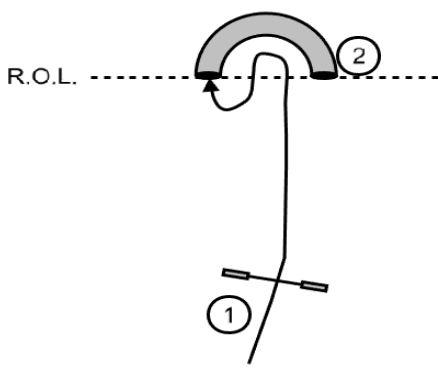

Faults = run-out & wrong course

Diagram 5.4.1-D

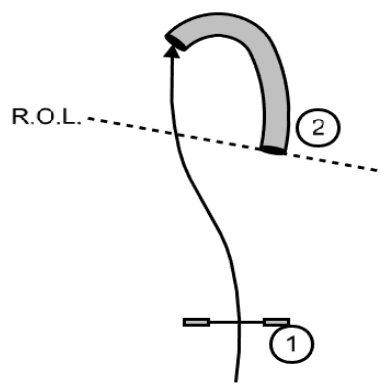

Faults = run-out & wrong course

Diagram 5.4.1-E

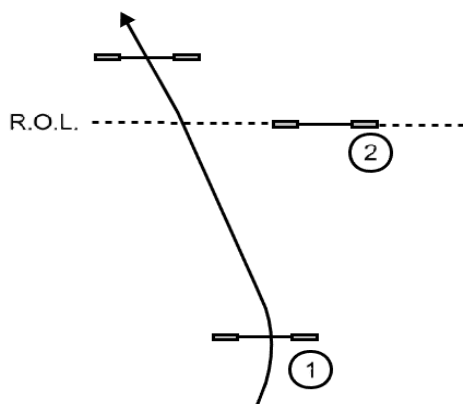

Faults = run-out & wrong course

Diagram 5.4.1-F

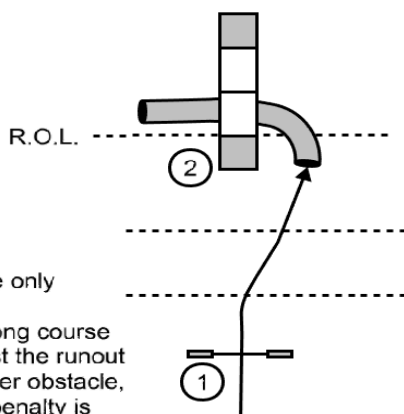

Faults = wrong course only

If the dog incurs a wrong course fault that carries it past the runout plane of the next proper obstacle, only a wrong course penalty is assessed for this action.

Diagram 5.4.2-A

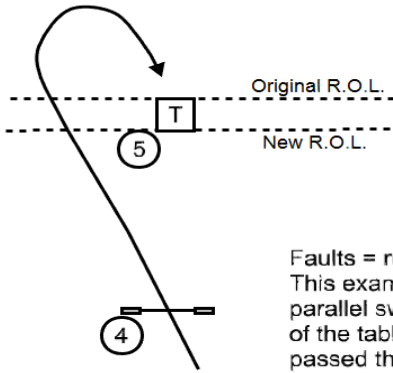

Faults = runout only.
 This example illustrates the parallel switch of the R.O.L. of the table once the dog has passed the original R.O.L.

Diagram 5.4.2-B

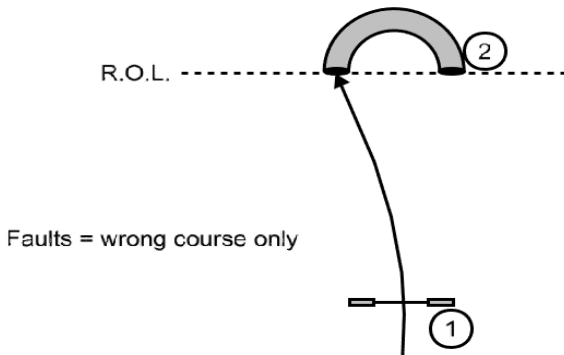

Faults = wrong course only

Diagram 5.4.2-C

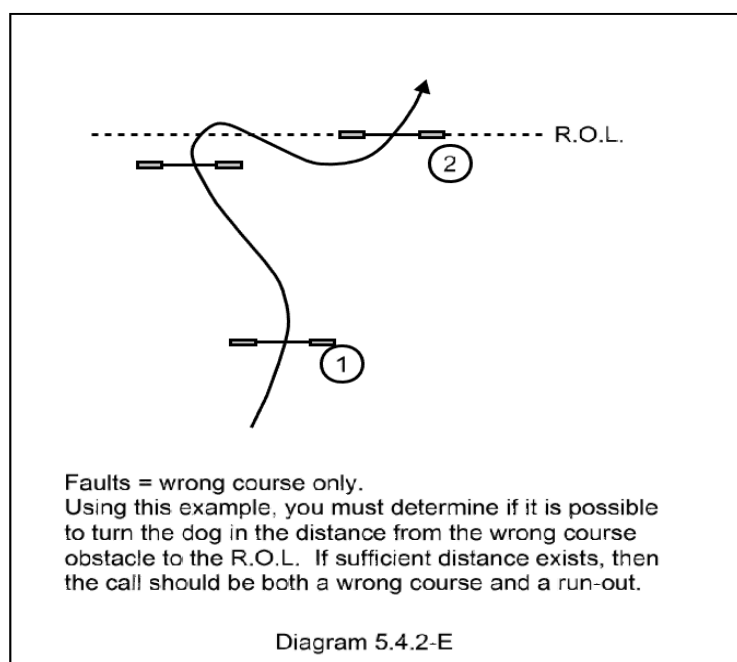
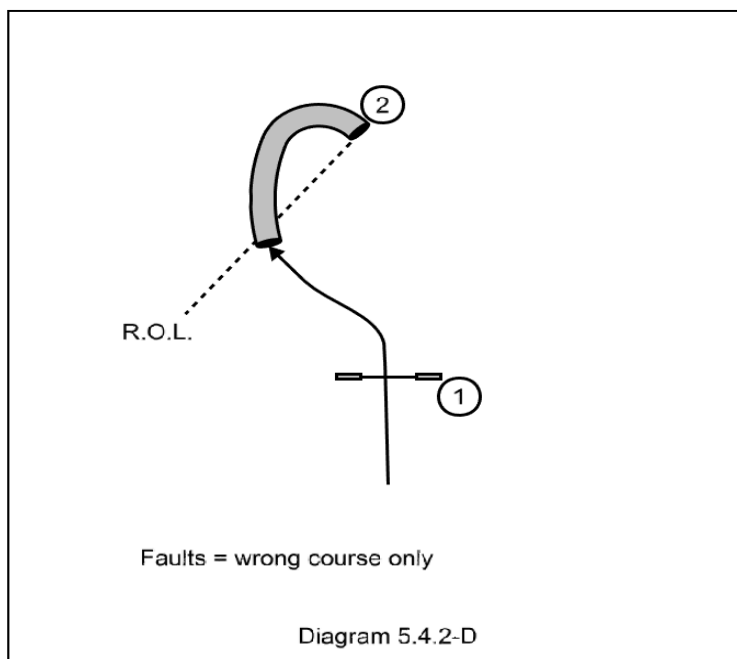

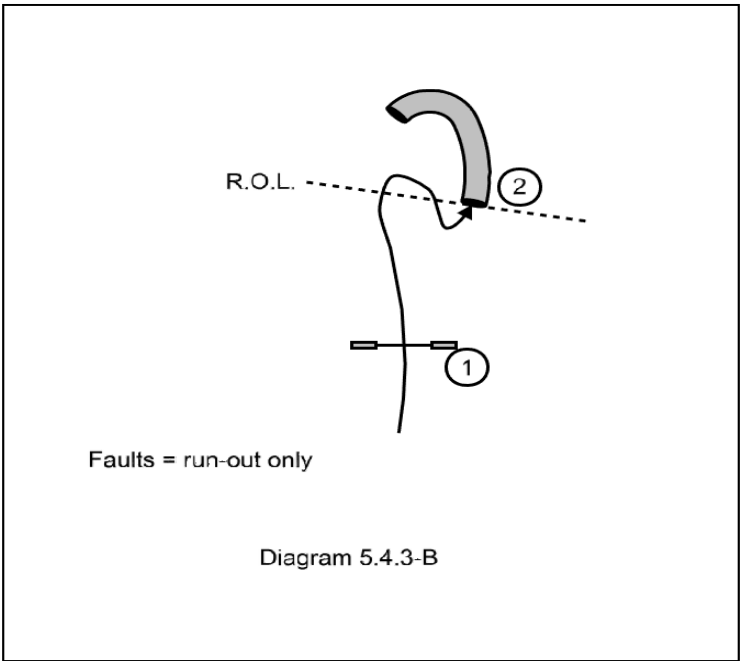
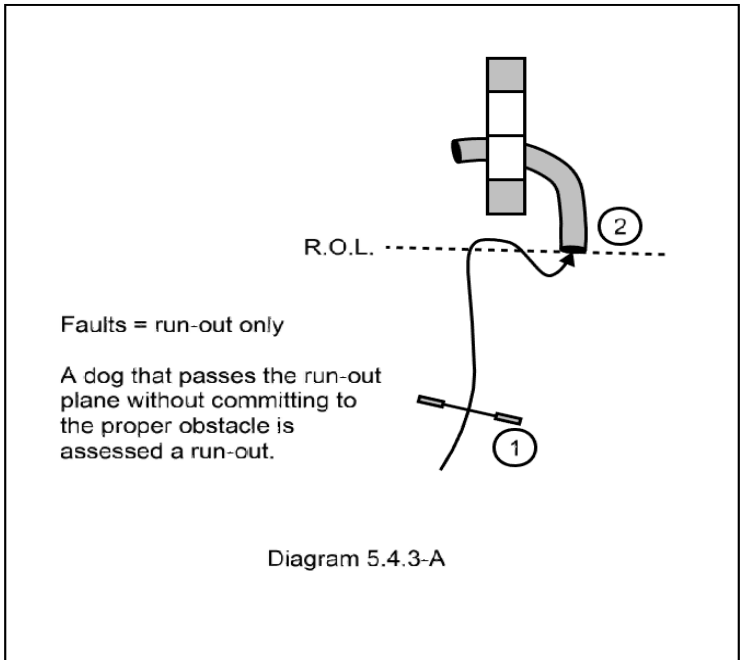

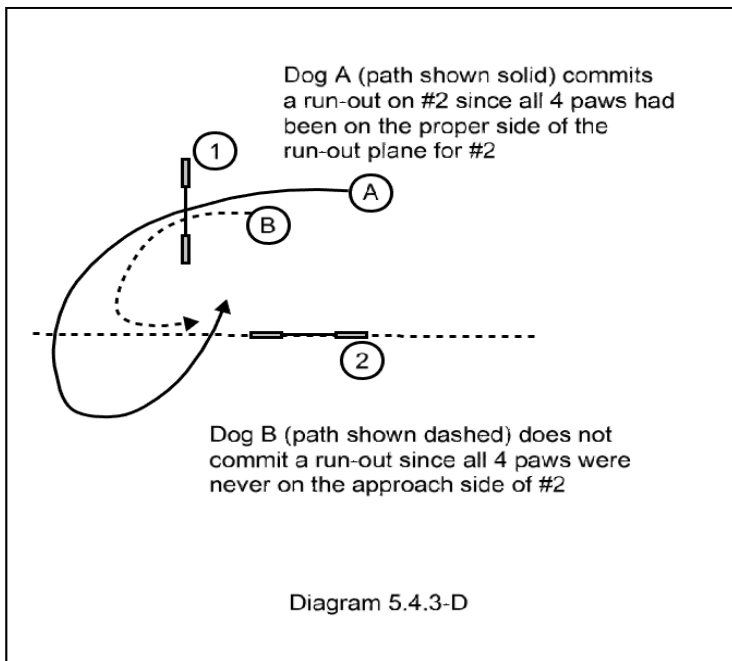
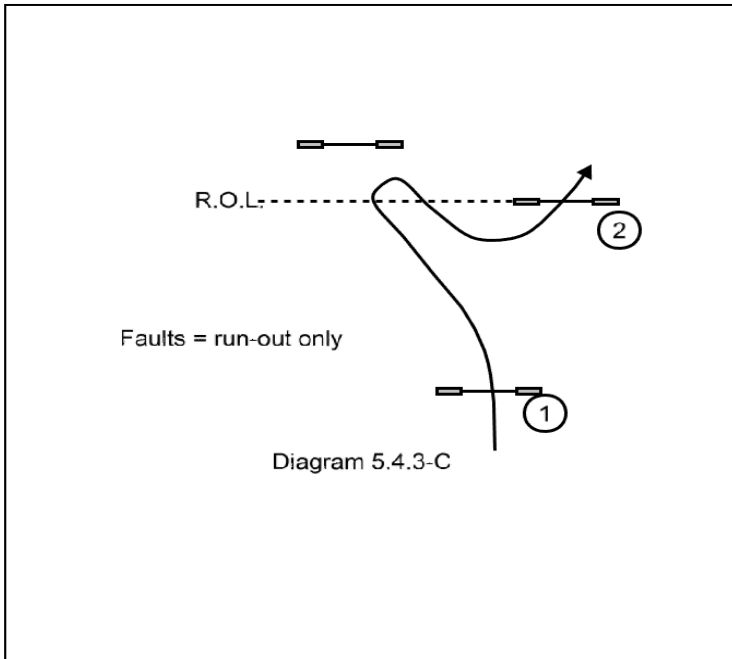

A dog that clearly avoids the proper obstacle (after seeing it) then commits with one or more paws to another obstacle, is faulted for both a refusal and a wrong course, since these are two separate actions.

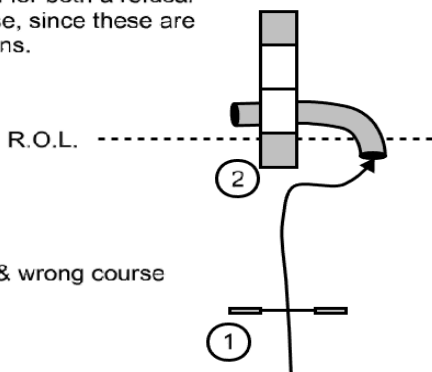

Faults = refusal & wrong course

Diagram 5.4.4-A

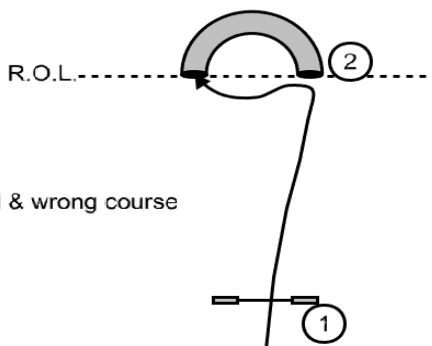

Faults = refusal & wrong course

Diagram 5.4.4-B

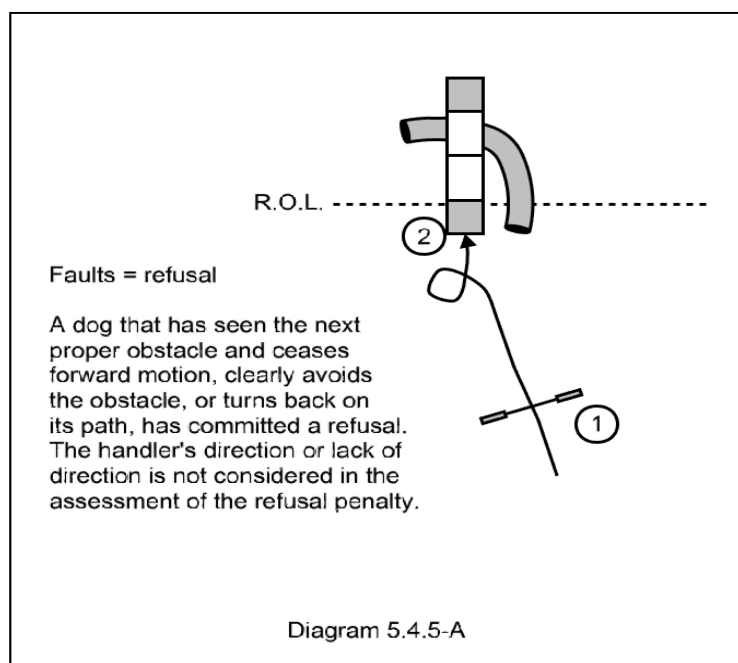
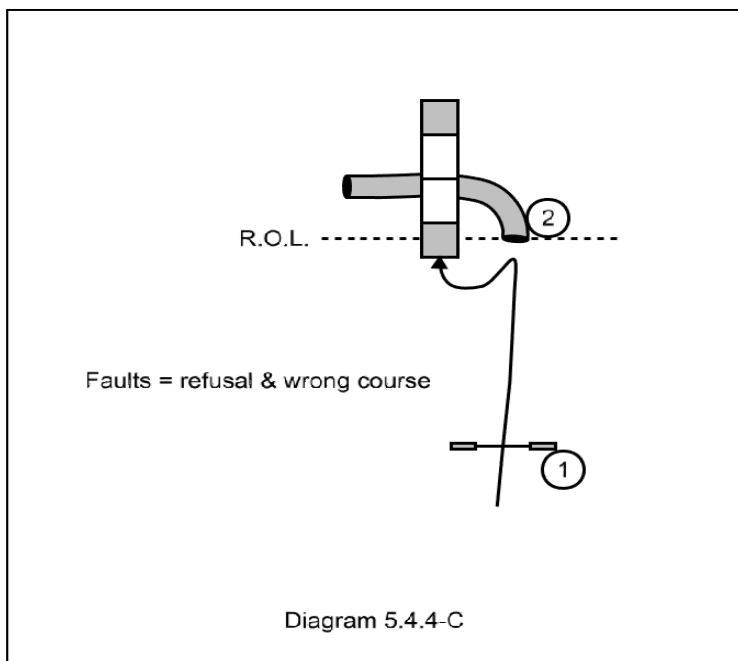

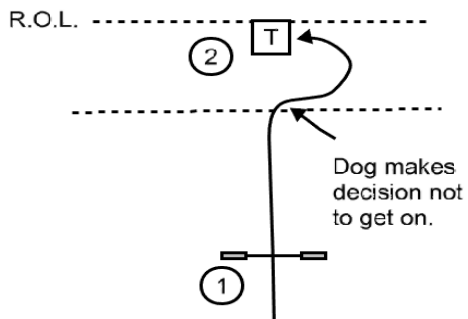

Faults = refusal

Dog approaches table, avoids the side they're approaching, and then gets on another side.

Diagram 5.4.5-B

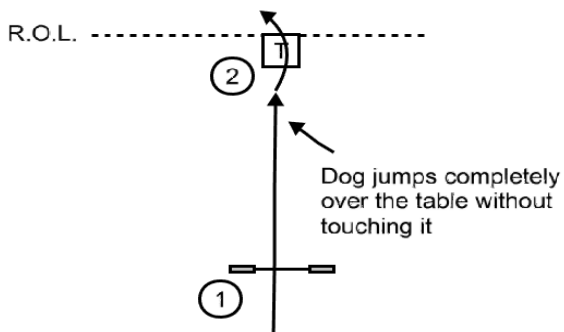

Faults = refusal

Dog jumps over the table; the act causes the dog to cross the run-out line, thus only a refusal is called.

Diagram 5.4.5-B2

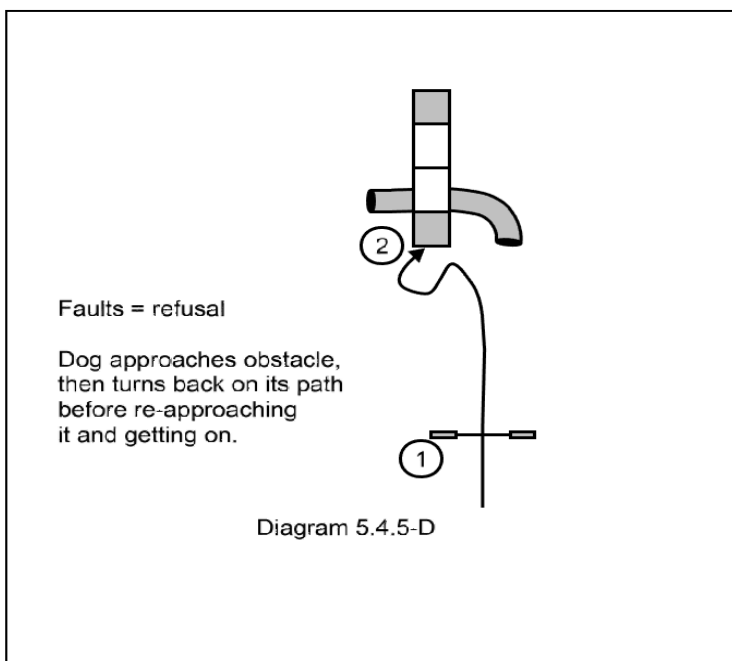
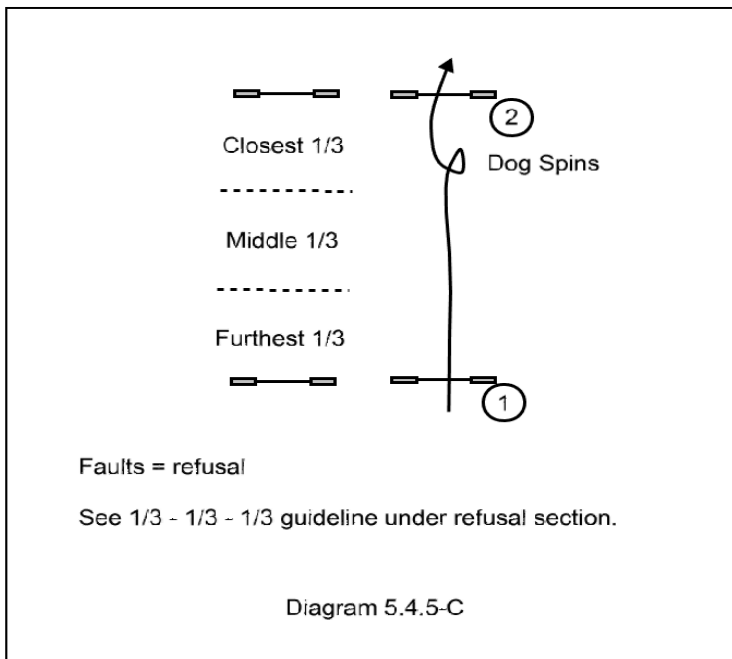

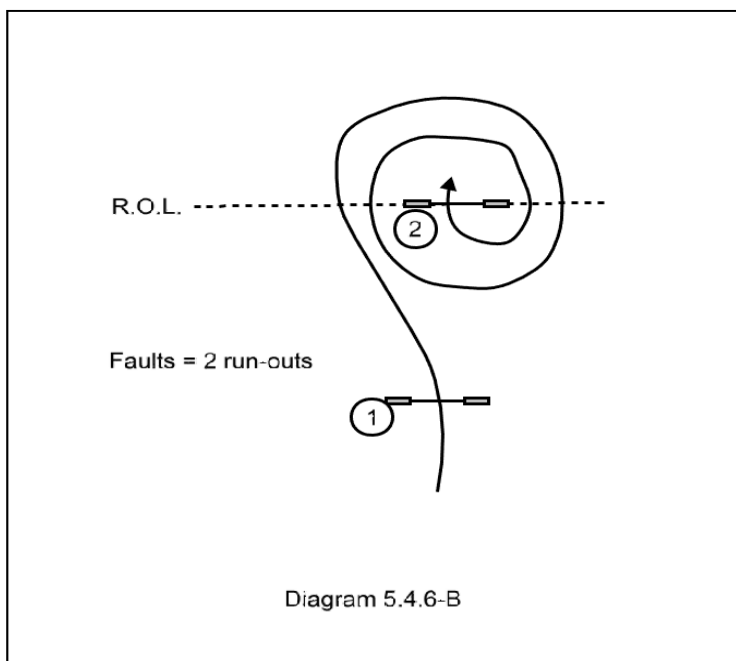
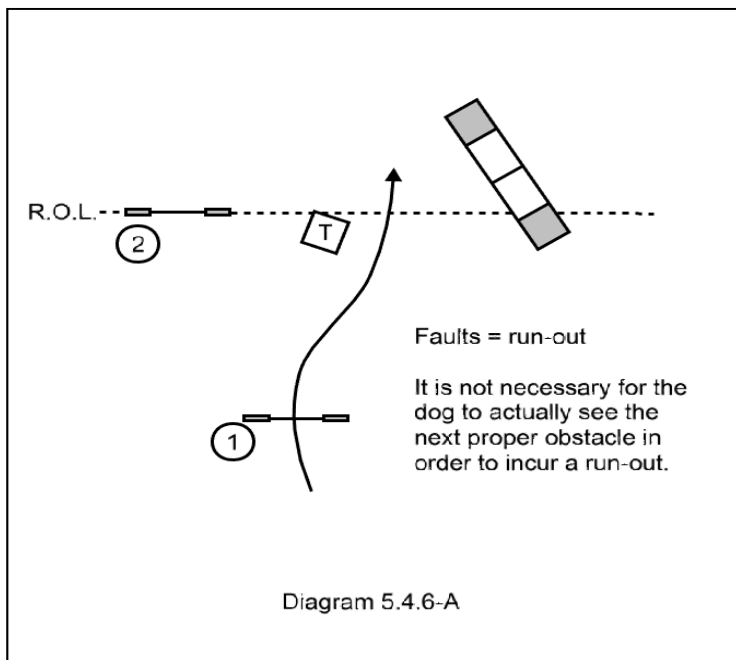

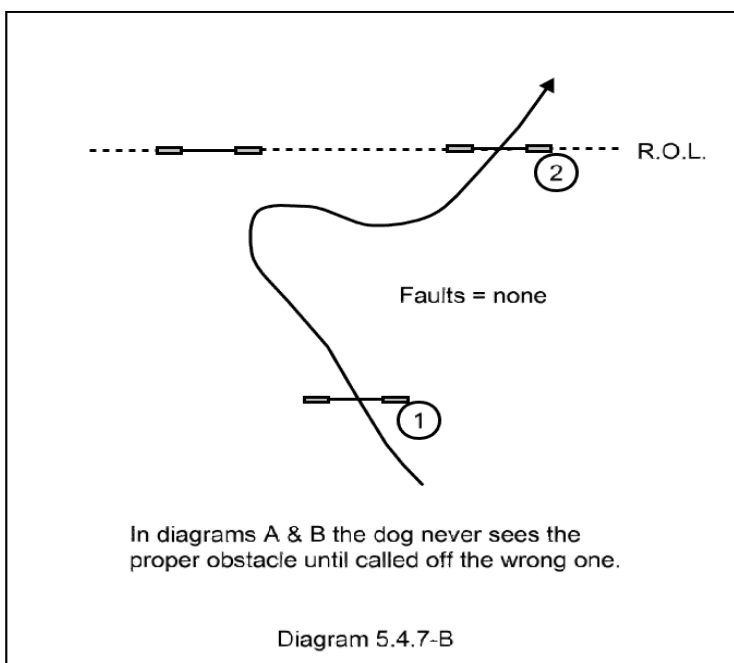
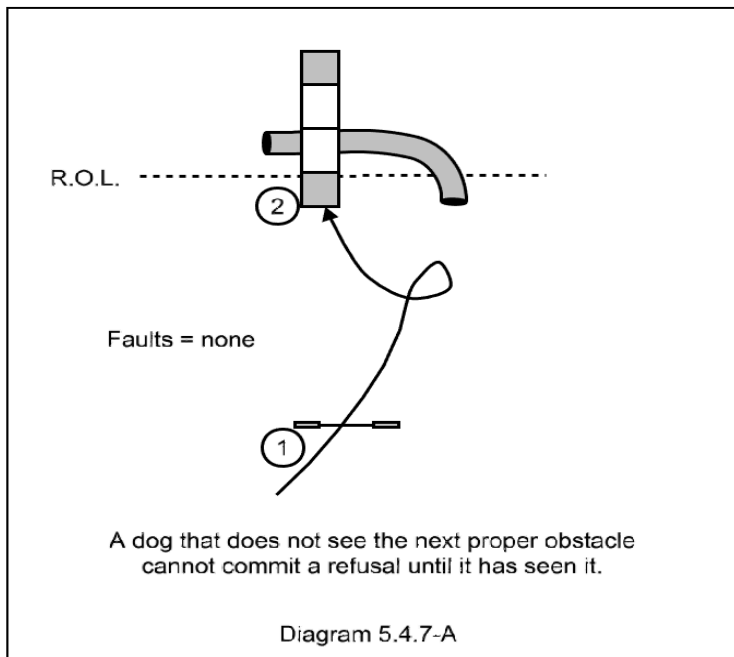

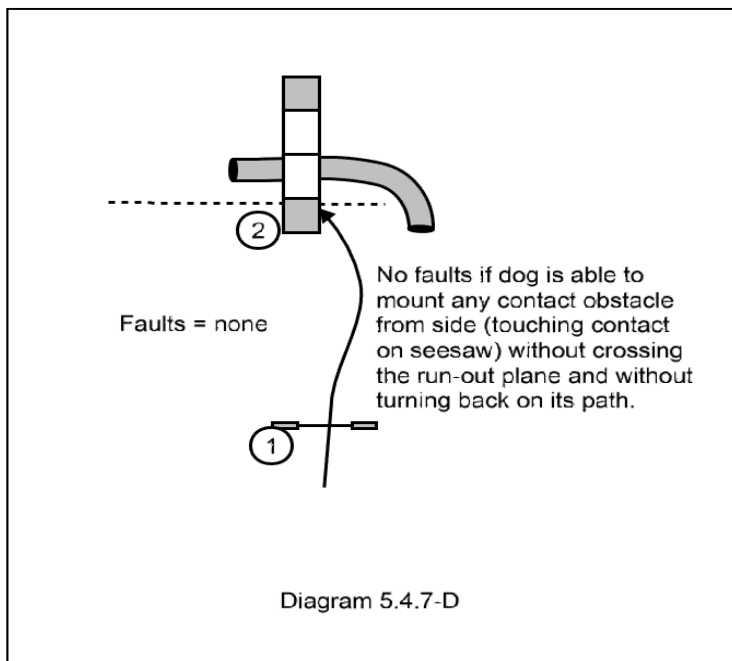
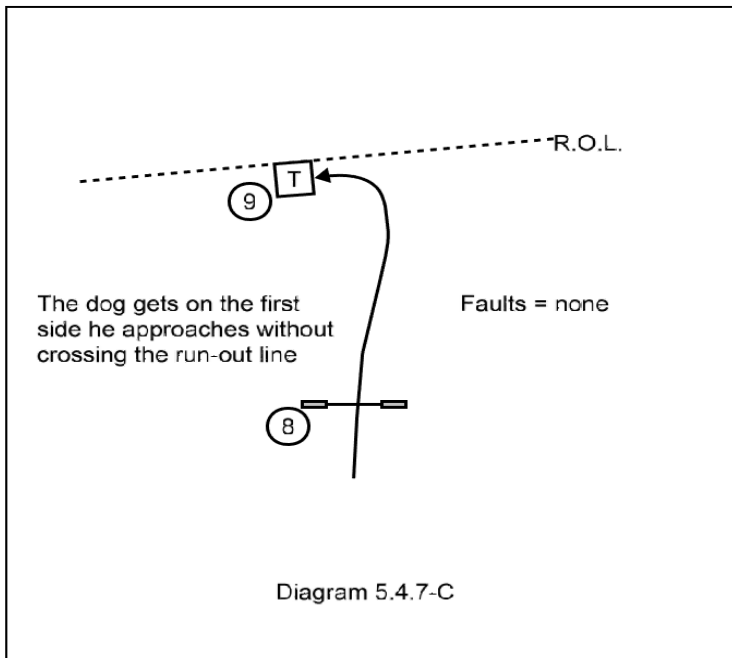

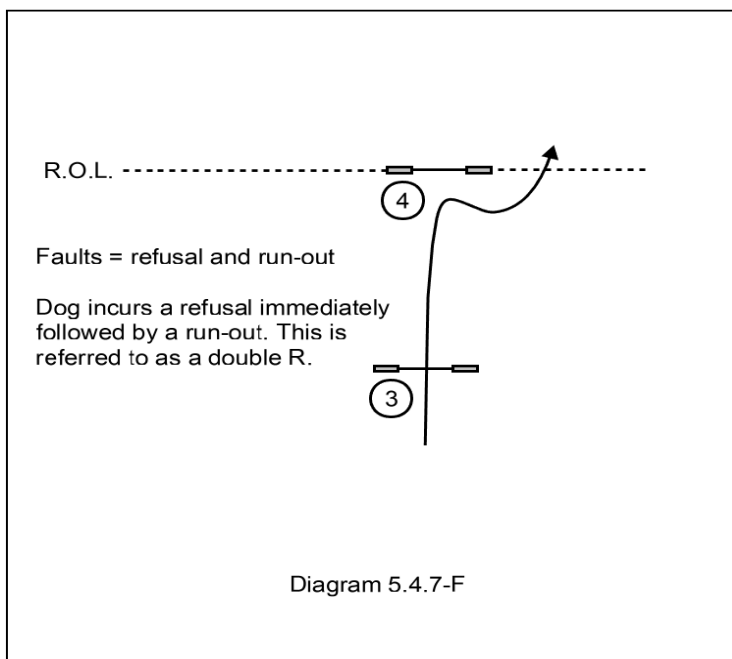
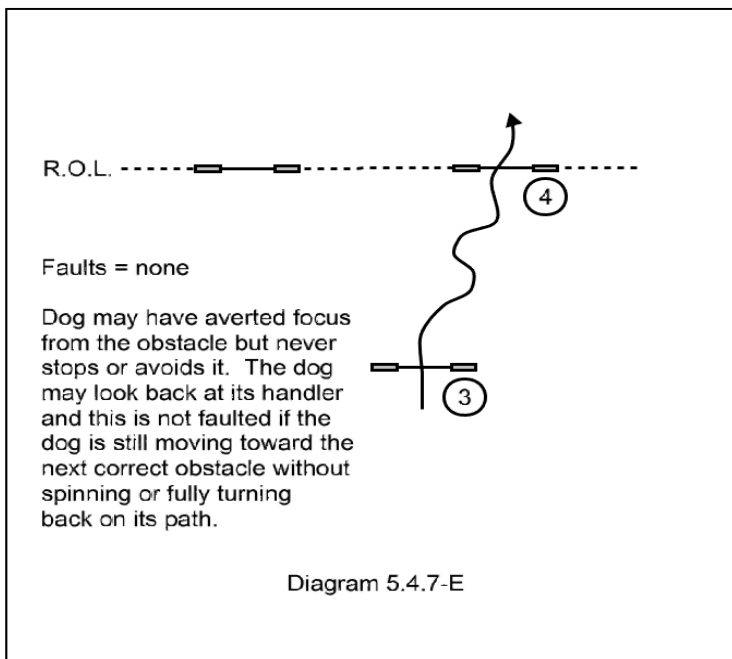

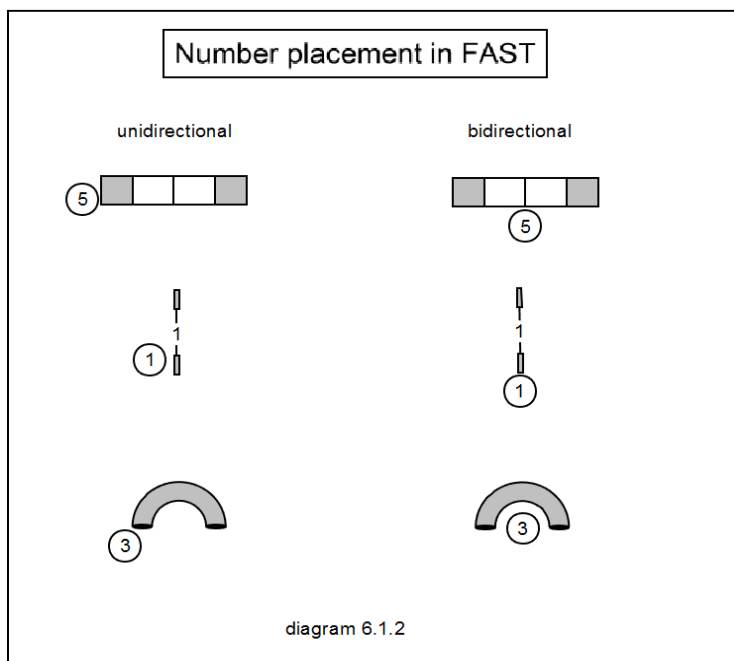
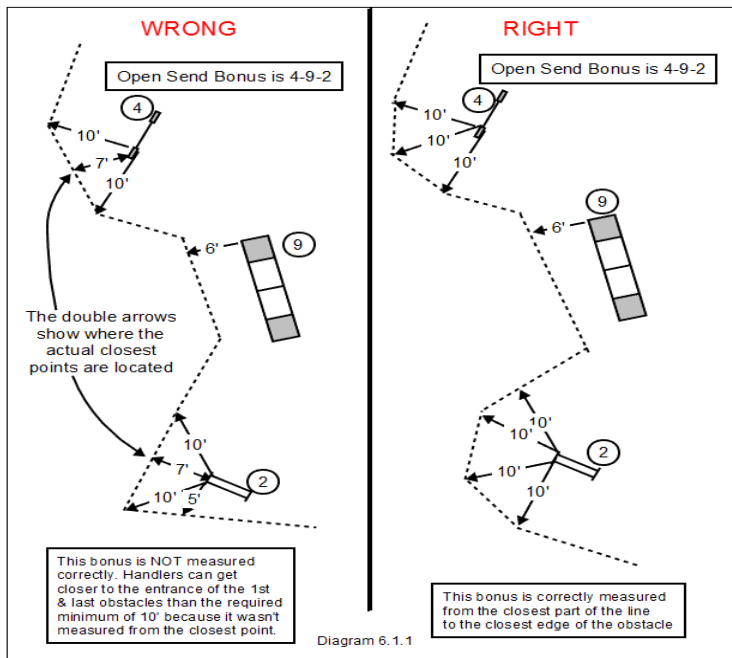

Any obstacle in a Combo may be also taken for a separate point value as long as the points can not be awarded when taken in the same direction as the flow of the combo.

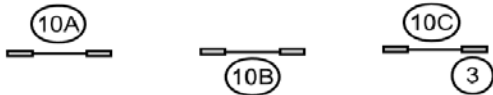
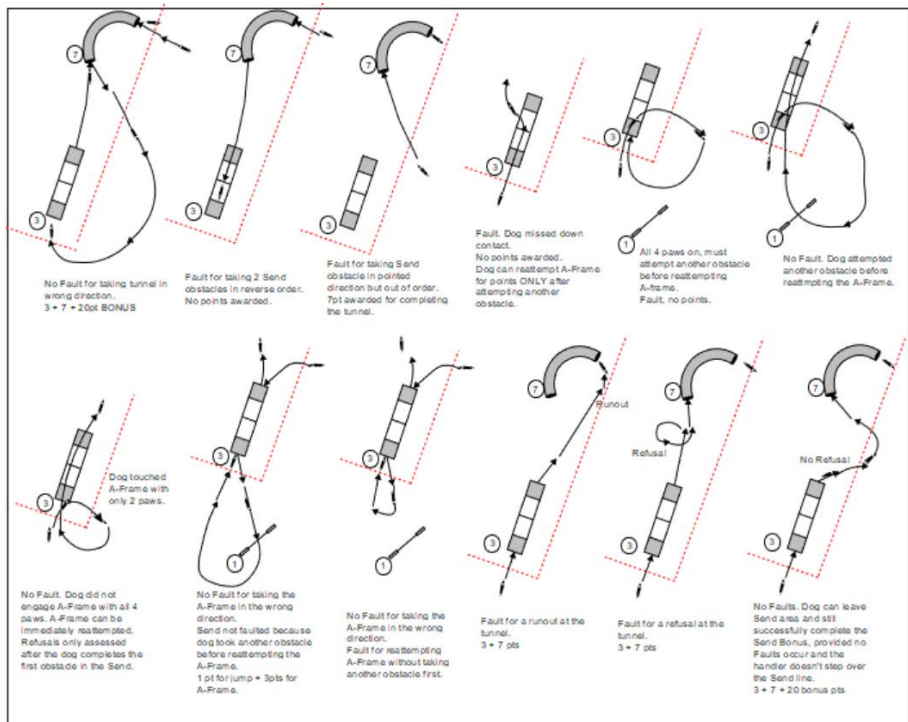

Diagram 6.1.3



Numbering a bidirectional obstacle in Premier and T2B

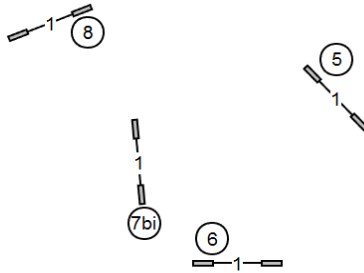

diagram 7.1.1

EXAMPLES OF PREMIER CLASS CHALLENGES updated 04/04/16

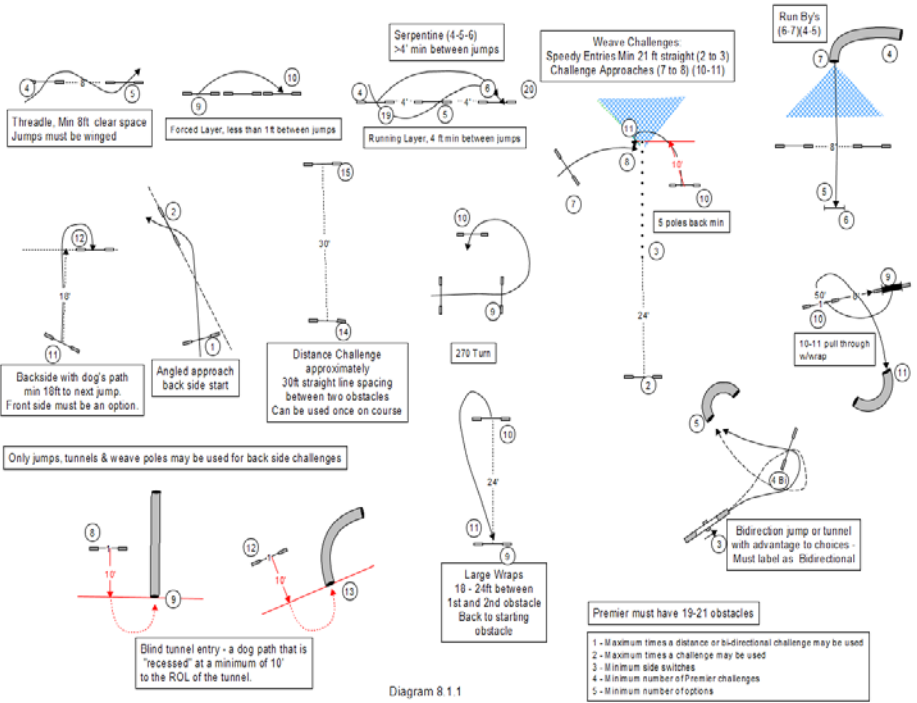

Diagram 8.1.1

MORE EXAMPLES OF PREMIER CLASS CHALLENGES

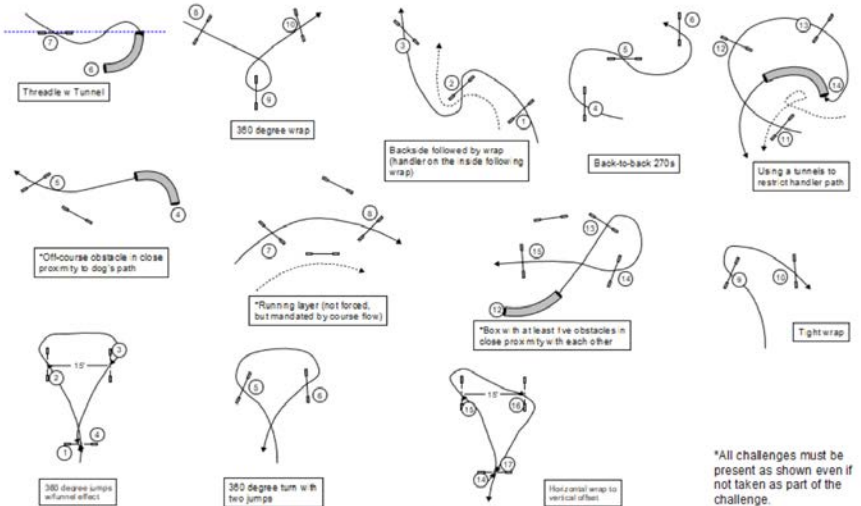

Diagram 8.1.2

Summary

Armed with this set of guidelines, the AKC Regulations for Agility Trials, common sense, and professionalism, you should feel confident in completing your judging assignments. The AKC has trusted you to fairly implement the regulations of the AKC agility program while maintaining the role of ambassador for the sport of dog agility. As always, your dedication and hard work in this endeavor are greatly appreciated.

AKC Code of Sportsmanship

PREFACE: The sport of purebred dog competitive events dates prior to 1884, the year of AKC's birth. Shared values of those involved in the sport include principles of sportsmanship. They are practiced in all sectors of our sport: conformation, performance and companion. Many believe that these principles of sportsmanship are the prime reason why our sport has thrived for over one hundred years. With the belief that it is useful to periodically articulate the fundamentals of our sport, this code is presented.

- Sportsmen respect the history, traditions and integrity of the sport of purebred dogs.
- Sportsmen commit themselves to values of fair play, honesty, courtesy, and vigorous competition, as well as winning and losing with grace.
- Sportsmen refuse to compromise their commitment and obligation to the sport of purebred dogs by injecting personal advantage or consideration into their decisions or behavior.
- The sportsman judge judges only on the merits of the dogs and considers no other factors.
- The sportsman judge or exhibitor accepts constructive criticism.
- The sportsman exhibitor declines to enter or exhibit under a judge where it might reasonably appear that the judge's placements could be based on something other than the merits of the dogs.
- The sportsman exhibitor refuses to compromise the impartiality of a judge.
- The sportsman respects the AKC bylaws, rules, regulations and policies governing the sport of purebred dogs.
- Sportsmen find that vigorous competition and civility are not inconsistent and are able to appreciate the merit of their competition and the effort of competitors.
- Sportsmen welcome, encourage and support newcomers to the sport.
- Sportsmen will deal fairly with all those who trade with them.
- Sportsmen are willing to share honest and open appraisals of both the strengths and weaknesses of their breeding stock.
- Sportsmen spurn any opportunity to take personal advantage of positions offered or bestowed upon them.
- Sportsmen always consider as paramount the welfare of their dog.
- Sportsmen refuse to embarrass the sport, the American Kennel Club, or themselves while taking part in the sport.

