

CUSTOMS CO-OPERATION COUNCIL

GENERAL SECRETARIAT

---

**CUSTOMS CONVENTION  
ON CONTAINERS, 1972**

done at Geneva, 2nd December 1972

under the auspices of the United Nations/International Maritime Organization

---

**CUSTOMS CONVENTION ON CONTAINERS, 1972**

---

UN/IMO 1972

**CUSTOMS CONVENTION  
ON CONTAINERS, 1972**

PREAMBLE

THE CONTRACTING PARTIES,

DESIRING to develop and facilitate international carriage by container,

HAVE AGREED as follows:

CHAPTER I

**General**

Article 1

For the purposes of the present Convention:

- (a) the term "import duties and taxes" shall mean Customs duties and all other duties, taxes, fees and other charges which are collected on, or in connection with, the importation of goods, but not including fees and charges limited in amount to the approximate cost of services rendered;
- (b) the term "temporary admission" shall mean temporary importation, subject to re-exportation, free of import duties and taxes and free of import prohibitions and

restrictions;

- (c) the term "container" shall mean an article of transport equipment (lift-van, movable tank or other similar structure):
  - (i) fully or partially enclosed to constitute a compartment intended for containing goods;
  - (ii) of a permanent character and accordingly strong enough to be suitable for repeated use;
  - (iii) specially designed to facilitate the carriage of goods, by one or more modes of transport, without intermediate reloading;
  - (iv) designed for ready handling, particularly when being transferred from one mode of transport to another;
  - (v) designed to be easy to fill and to empty; and
  - (vi) having an internal volume of one cubic metre or more;

the term "container" shall include the accessories and equipment of the container, appropriate for the type concerned, provided that such accessories and equipment are carried with the container. The term "container" shall not include vehicles, accessories or spare parts of vehicles, or packaging. Demountable bodies, are to be treated as containers;

- (d) the term "internal traffic" shall mean the carriage of goods loaded in the territory of a State for unloading at a place within the territory of the same State;
- (e) the term "person" shall mean both natural and legal persons;
- (f) the term "operator" of a container shall mean the person who, whether or not its owner, has effective control of its use.

## Article 2

In order to benefit from the facilities provided for in the present Convention, containers shall be marked in the manner prescribed in Annex 1.

## CHAPTER II

### Temporary admission

#### (a) Temporary admission facilities

##### Article 3

1. Subject to the conditions laid down in Articles 4 to 9, each Contracting Party shall grant temporary admission to containers, whether loaded with goods or not.
2. Each Contracting Party reserves the right not to grant temporary admission to containers which have been the subject of purchase, hire-purchase, lease or a contract of a similar nature, concluded by a person resident or established in its territory.

##### Article 4

1. Containers granted temporary admission shall be re-exported within three months from the date of importation. However, this period may be extended by the competent Customs authorities.
2. Containers granted temporary admission may be re-exported through any competent Customs office, even if that office is different from the one of temporary admission.

##### Article 5

1. Notwithstanding the requirement of re-exportation laid down in Article 4, paragraph 1, seriously damaged containers shall not be required to be re-exported provided that, in conformity with the regulations of the country concerned and as the Customs authorities of that country may authorize, the containers are :
  - (a) subjected to the import duties and taxes to which they are liable at the time when, and in the condition in which, they are presented; or
  - (b) abandoned, free of all expense, to the competent authorities of that country; or
  - (c) destroyed, under official supervision, at the expense of the parties concerned, any parts or materials salvaged being subjected to the import duties and taxes to which they are liable at the time when, and in the condition in which, they are presented.
2. If, as a result of a seizure, a container granted temporary admission cannot be re-exported, the requirement of re-exportation laid down in Article 4, paragraph 1, shall be suspended for the duration of the seizure.

## (b) Temporary admission procedures

### Article 6

Without prejudice to the provisions of Articles 7 and 8, containers temporarily imported under the terms of the present Convention shall be granted temporary admission without the production of Customs documents being required on their importation and reexportation and without the furnishing of a form of security.

### Article 7

Each Contracting Party may require that the temporary admission of containers be subject to compliance with all, or part of, the provisions of the procedure for temporary admission of containers, set out in Annex 2.

#### Article 8

Each Contracting Party shall retain the right, when the provisions of Article 6 cannot be applied, to require the furnishing of a form of security and/or the production of Customs documents on the importation or re-exportation of the container.

#### *(c) Conditions of use of containers granted temporary admission*

#### Article 9

- 1 Contracting Parties shall permit containers granted temporary admission under the terms of the present Convention to be used for the carriage of goods in internal traffic, in which case each Contracting Party shall be entitled to impose one or more of the conditions set out in Annex 3.
- 2 The facility provided for in paragraph 1 shall be granted without prejudice to the regulations in force in the territory of each Contracting Party regarding vehicles either drawing or carrying containers.

#### *(d) Special cases*

#### Article 10

1. Temporary admission shall be granted to component parts intended for the repair of temporarily admitted containers.
2. Replaced parts not re-exported shall, in conformity with the regulations of the country concerned and as the Customs authorities of that country may authorize, be :
  - (a) subjected to the import duties and taxes to which they are liable at the time when, and in the condition in which, they are presented; or
  - (b) abandoned, free of all expense, to the competent authorities of that country; or
  - (c) destroyed, under official supervision, at the expense of the parties concerned.
3. The provisions of Articles 6, 7 and 8 shall be applicable mutatis mutandis to temporary admission of component parts, referred to in paragraph 1.

## Article 11

1. The Contracting Parties agree to grant temporary admission to accessories and equipment of temporarily admitted containers, which are either imported with a container to be re-exported separately or with another container, or imported separately to be re-exported with a container.
2. The provisions of Article 3, paragraph 2, and Articles 4, 5, 6, 7 and 8 shall be applicable mutatis mutandis to the temporary admission of accessories and equipment of containers, referred to in paragraph 1. Such accessories and equipment may be used in internal traffic under the terms of Article 9, paragraph 1, when carried with a container covered by the provisions of the said paragraph.

## CHAPTER III

### **Approval of containers for transport under Customs seal**

## Article 12

1. To qualify for approval for transport of goods under Customs seal, containers shall comply with the provisions of the Regulations set out in Annex 4.
2. Approval shall be granted under one of the procedures laid down in Annex 5.
3. Containers approved by a Contracting Party for the transport of goods under Customs seal shall be accepted by the other Contracting Parties for any system of international carriage involving such sealing.
4. Each Contracting Party reserves the right to refuse to recognize the validity of the approval of containers which are found not to meet the conditions set forth in Annex 4. Nevertheless, Contracting Parties shall avoid delaying traffic when the defects found are of minor importance and do not involve any risk of smuggling.
5. Before it is used again for the transport of goods under Customs seal, any container, the approval of which is no longer recognized, shall be either restored to the condition which had justified its approval or presented for reapproval.
6. Where a defect appears to have existed when the container was approved, the competent authority responsible for that approval shall be informed.
7. If it is found that containers approved for the transport of goods under Customs seal in accordance with the procedures described in Annex 5, paragraph 1 (a) and (b), do not in fact comply with the technical conditions of Annex 4, the authority which granted the approval shall take such steps as are necessary to bring the containers up to the required technical condition or to withdraw the approval.



## CHAPTER IV

### **Explanatory Notes**

#### Article 13

The Explanatory Notes set out in Annex 6 interpret some provisions of the present Convention and its Annexes.

## CHAPTER V

### **Miscellaneous provisions**

#### Article 14

The present Convention shall not prevent the application of greater facilities which Contracting Parties grant or may wish to grant either by unilateral provisions or in virtue of bilateral or multilateral agreements provided that such facilities do not impede the application of the provisions of the present Convention.

#### Article 15

Any contravention of the provisions of the present Convention, and any substitution, false declaration, or act having the effect of causing a person or an article improperly to benefit from the provisions of the present Convention, may render the offender liable, in the country where the offence was committed, to the penalties prescribed by the laws of that country.

## Article 16

The Contracting Parties shall communicate to one another, on request, the information necessary for implementing the provisions of the present Convention, and more particularly information relating to the approval of containers and to the technical characteristics of their design.

## Article 17

The Annexes to the present Convention and the Protocol of Signature form an integral part of the Convention.

## CHAPTER VI

### **Final clause**

## Article 18

### **Signature, ratification, acceptance, approval and accession**

1. The present Convention shall be open for signature until 15 January 1973 at the Office of the United Nations at Geneva and subsequently from 1 February 1973 until 31 December 1973 inclusive at the Headquarters of the United Nations at New York by all State Members of the United Nations or of any of the specialized agencies or of the International Atomic Energy Agency or parties to the Statute of the International Court of Justice, and by any other State invited by the General Assembly of the United Nations to become a Party to the present Convention.
2. The present Convention is subject to ratification, acceptance or approval by States which have signed it.
3. The present Convention shall remain open for accession by any State referred to in paragraph 1.
4. Instruments of ratification, acceptance, approval or accession shall be deposited with the Secretary General of the United Nations.

## Article 19

### **Entry into force**

1. The present Convention shall enter into force nine months from the date of the deposit of the fifth instrument of ratification, acceptance, approval or accession.
2. For each State ratifying, accepting, approving or acceding to the present

Convention after the deposit of the fifth instrument of ratification, acceptance, approval or accession, the present Convention shall enter into force six months after the date of the deposit by such State of its instrument of ratification, acceptance, approval or accession.

3. Any instrument of ratification, acceptance, approval or accession deposited after the entry into force of an amendment to the present Convention shall be deemed to apply to the Convention as amended.
4. Any such instrument deposited after an amendment has been accepted but before it has entered into force shall be deemed to apply to the Convention as amended on the date when the amendment enters into force.

## Article 20

### **Termination of the operation of the Customs Convention on Containers (1956)**

1. Upon its entry into force, the present Convention shall terminate and replace, relations between the Parties to the present Convention, the Customs Convention on Containers, opened for signature at Geneva on 18 May 1956.
2. Notwithstanding the provisions of Article 12, paragraphs 1, 2 and 4, containers approved under the provisions of the Customs Convention on Containers (1956) or under the agreements arising therefrom concluded under the auspices of the United Nations, shall be accepted by any Contracting Party for the transport of goods under Customs seal, provided that they continue to comply with the relevant conditions under which they were originally approved. For this purpose certificates of approval issued under the provisions of the Customs Convention on Containers (1956) could be replaced by an approval plate prior to the expiry of their validity.

## Article 21

### **Procedures for amending the present Convention including its Annexes**

1. Any Contracting Party may propose one or more amendments to the present Convention. The text of any proposed amendment shall be notified to the Customs Co-operation Council which shall communicate it to all Contracting Parties and inform the States referred to in Article 18 which are not Contracting Parties. The Customs Co-operation Council shall also, in accordance with the rules of procedure set out in Annex 7, convene an Administrative Committee.
2. Any amendment proposed in accordance with the preceding paragraph, or prepared during the meeting of the Committee, and adopted by a two-thirds majority of those present and voting in the Committee, shall be communicated to the Secretary General of the United Nations.
3. The Secretary General of the United Nations shall communicate the amendment to the Contracting Parties for their acceptance, and to the States referred to in Article 18 which are not Contracting Parties for their information.
4. Any proposed amendment communicated in accordance with the preceding paragraph shall be deemed to be accepted if no Contracting Party expressed an objection within a period of 12 months following the date of communication of the proposed amendment by the Secretary General of the United Nations.
5. The Secretary General of the United Nations shall, as soon as possible, notify all Contracting Parties and the States referred to in Article 18 which are not Contracting Parties whether an objection to the proposed amendment has been expressed. If an objection to the proposed amendment has been communicated to the Secretary General of the United Nations the amendment shall be deemed not to have been accepted and shall be of no effect whatever. If no such objection has been communicated to the Secretary General of the United Nations the amendment shall enter into force for all Contracting Parties three months after the expiry of the period of 12 months referred to in the preceding paragraph, or on such later date as may have been determined by the Administrative Committee at the time of its adoption.
6. Any Contracting Party may, by notification to the Secretary General of the United Nations, request that a conference be convened for the purpose of reviewing the present Convention. The Secretary General of the United Nations shall notify all Contracting Parties of the request and a revision conference shall be convened by the Secretary General of the United Nations if, within a period of four months following the date of notification by the Secretary General of the United Nations, not less than one-third of the Contracting Parties notify him of their concurrence with the request. Such conference shall also be convened by the Secretary General of the United Nations upon notification of a request by the Administrative Committee. The Administrative Committee shall make such a request if agreed to by a majority of those present and voting in the Committee. If a conference is convened in accordance with this paragraph, the Secretary General of the United Nations shall invite to it all States referred to in Article 18.

## Article 22

### **Special procedure for amending Annexes 1, 4, 5 and 6**

1. Independently of the amendment procedures set out in Article 21, Annexes 1, 4, 5, and 6 may be amended as provided for in this Article and in accordance with the rules of procedure set out in Annex 7.
2. Any Contracting Party shall communicate proposed amendments to the Customs Co-operation Council. The Customs Co-operation Council shall bring them to the attention of the Contracting Parties and of the States referred to in Article 18 which are not Contracting Parties, and shall convene the Administrative Committee.
3. Any amendment proposed in accordance with the preceding paragraph or prepared during the meeting of the Committee, and adopted by a two-thirds majority of those present and voting in the Committee, shall be communicated to the Secretary General of the United Nations.
4. The Secretary General of the United Nations shall communicate the amendment to the Contracting Parties for their acceptance, and to the States referred to in Article 18 which are not Contracting Parties for their information.
5. The amendment shall be deemed to have been accepted unless one-fifth or five of the Contracting Parties, whichever number is less, have notified the Secretary General of the United Nations, within a period of 12 months from the date on which the proposed amendment has been communicated by the Secretary General of the United Nations to the Contracting Parties, that they object to the proposal. A proposed amendment which is not accepted shall be of no effect whatever.
6. If an amendment is accepted, it shall enter into force, for all Contracting Parties which did not object to the proposed amendment, three months after the expiry of the period of 12 months referred to in the preceding paragraph, or on such later date as may have been determined by the Administrative Committee at the time of its adoption. At the time of adoption of an amendment, the Committee may also provide that, during a transitional period, the existing Annexes shall remain in force, wholly or in part, concurrently with such amendment.
7. The Secretary General of the United Nations shall notify the date of the entry into force of the amendment to the Contracting Parties and inform the States referred to in Article 18 which are not Contracting Parties.

## Article 23

### **Denunciation**

Any Contracting Party may denounce the present Convention by effecting the deposit of an instrument with the Secretary General of the United Nations. The denunciation shall take effect one year from the date of such deposit with the Secretary General of the United Nations.

## Article 24

### **Termination**

The present Convention shall cease to be in force if the number of Contracting Parties is less than five for any period of twelve consecutive months.

## Article 25

### **Settlement of disputes**

1. Any dispute between two or more Contracting Parties concerning the interpretation or application of the present Convention which cannot be settled by negotiation or other means of settlement shall, at the request of one of them, be referred to an arbitration tribunal composed as follows : each party to the dispute shall appoint an arbitrator and these two arbitrators shall appoint a third arbitrator, who shall be Chairman. If three months after receipt of a request, one of the parties has failed to appoint an arbitrator or if the arbitrators have failed to elect the Chairman, any of the parties may request the Secretary General of the United Nations to appoint an arbitrator or the Chairman of the arbitration tribunal.
2. The decision of the arbitration tribunal established under the provisions of paragraph 1 shall be binding on the parties to the dispute.
3. The arbitration tribunal shall determine its own rules of procedure.
4. Decisions of the arbitration tribunal, both as to its procedure and its place of meeting and as to any controversy laid before it, shall be taken by majority vote.
5. Any controversy which may arise between the parties to the dispute as regards the interpretation and execution of the award may be submitted by any of the parties for judgement to the arbitration tribunal which made the award.

## Article 26

### Reservations

1. Reservations to the present Convention shall be permitted, excepting those relating to the provisions of Articles 1 to 8, 12 to 17, 20, 25 and of the present Article, and those relating to the provisions contained in the Annexes, on condition that such reservations are communicated in writing and, if communicated before the deposit of the instrument of ratification, acceptance, approval or accession, are confirmed in that instrument. The Secretary General of the United Nations shall communicate such reservations to all States referred to in Article 18.
2. Any reservation made in accordance with paragraph 1 :
  - (a) modifies for the Contracting Party which made the reservation the provisions of the present Convention to which the reservation relates, to the extent of the reservation; and
  - (b) modifies those provisions to the same extent for the other Contracting Parties in their relations with the Contracting Party which entered the reservation.
3. Any Contracting Party which has communicated a reservation under paragraph 1 may withdraw it at any time by notification to the Secretary General of the United Nations.

## Article 27

### Notification

In addition to the notifications and communications provided for in Articles 21, 22 and 26, the Secretary General of the United Nations shall notify all the States referred to in Article 18 of the following:

- (a) signatures, ratifications, acceptances, approvals and accessions under Article 18;
- (b) the dates of entry into force of the present Convention in accordance with Article 19;
- (c) the date of entry into force of amendments to the present Convention in accordance with Articles 21 and 22;
- (d) denunciations under Article 23;
- (e) the termination of the present Convention under Article 24.

## Article 28

### **Authentic texts**

The original of the present Convention, of which the Chinese, English, French, Russian and Spanish texts are equally authentic, shall be deposited with the Secretary General of the United Nations, who shall communicate certified true copies to all States referred to in Article 18.

IN WITNESS WHEREOF the undersigned Plenipotentiaries, being duly authorized thereto by their respective Governments, have signed the present Convention.

DONE at Geneva this second day of December one thousand nine hundred and seventy-two.



## ANNEX 1

### Provisions concerning the marking of containers

1. The following information shall be durably marked in an appropriate and clearly visible place on containers:
  - (a) the identification of the owner or principal operator, which may be shown either by its full name or by an established identification system, symbols such as emblems or flags being excluded;
  - (b) the identification marks and numbers of the container, given by the owner or principal operator; and
  - (c) the tare weight of the container, including all its permanently fixed equipment.
2. For freight containers generally considered for maritime use, or for any other container utilizing an ISO standard prefix (i.e. four capital letters ending in U), the identification of the owner or principal operator and the container serial number and check digit of the container shall adhere to the International Standard ISO 6346 and its annexes.
3. For identification marks and numbers on containers to be considered durably marked when plastic film is used, compliance with the following specifications is required:
  - (a) a high-quality adhesive shall be used. The film, once applied, shall have a tensile strength lower than its final adhesion so that removal of the film without destroying it is impossible. Film produced by the cast method of production meets these requirements. Film produced by the calendar method of production shall not be used;
  - (b) When identification marks and numbers have to be changed, the film to be replaced shall be removed completely prior to the affixing of the new film; placing of new film over an existing film shall not be permitted.
4. The specifications for the use of plastic film for marking containers set out in paragraph 3 of this Annex do not exclude the possibility of using other durable marking methods.
5. Containers approved for transport under Customs seal shall, in addition, bear the following details which shall also be put on the approval plate in accordance with the provisions of Annex 5 :
  - (a) the manufacturer's serial number (manufacturer's number); and
  - (b) if they have been approved by design type, the identification numbers or letters of the type.

## ANNEX 2

### Temporary admission procedure under Article 7

1. For the purpose of applying the provisions of Article 7 of the present Convention, each Contracting Party shall use, for checking movements of containers granted temporary admission, the records kept by the owners or operators or their representatives.
2. The following provisions shall be applied :
  - (a) the owner or operator of the containers will be represented in the country in which the containers are to be granted temporary admission;
  - (b) the owner or operator or the representative of either will undertake in writing :
    - (i) to supply to the Customs authorities of the said country, at their request, detailed information concerning the movements of each container granted temporary admission including the dates and places of entry into and exit from the said country;
    - (ii) to pay such import duties and taxes as may be required in cases where the conditions of temporary admission have not been fulfilled.

## ANNEX 3

### **Use of containers in internal traffic**

Each Contracting Party shall be entitled to impose the following conditions on the use, within its territory, as provided for in Article 9 of the present Convention, of containers in internal traffic :

- (a) the journey shall bring the container by a reasonably direct route to, or nearer to, the place where export cargo is to be loaded or from where the container is to be exported empty;
- (b) the container will be used only once in internal traffic before being re-exported.

## ANNEX 4

### **Regulations on technical conditions applicable to containers which may be accepted for international transport under Customs seal**

#### Article 1

##### **Basic principles**

Approval for the international transport of goods under Customs seal may be granted only to containers constructed and equipped in such a manner that :

- (a) no goods can be removed from, or introduced into, the sealed part of the container without leaving visible traces of tampering or without breaking the Customs seal;
- (b) Customs seals can be simply and effectively affixed to them;
- (c) they contain no concealed spaces where goods may be hidden;
- (d) all spaces capable of holding goods are readily accessible for Customs inspection.

#### Article 2

##### **Structure of containers**

1. To meet the requirements of Article 1 of these Regulations :
  - (a) the constituent parts of the container (sides, floor, doors, roof, uprights, frames, cross-pieces, etc.) shall be assembled either by means of devices which cannot be removed and replaced from the outside without leaving visible traces or by such methods as will produce a structure which cannot be modified without leaving visible traces. When the sides, floor, doors and roof are made up of various components, these shall meet the same requirements and be of sufficient strength;
  - (b) doors and all other closing systems (including stopcocks, manhole covers, flanges, etc.) shall be fitted with a device on which Customs seals can be fixed. This device must be such that it cannot be removed and replaced from outside the container without leaving visible traces, or the door or fastening be opened without breaking the Customs seals. The latter shall be adequately protected. Opening roofs shall be permitted;
  - (c) apertures for ventilation and drainage shall be provided with a device preventing access to the interior of the container. This device must be such that it cannot be removed and replaced from outside the container without leaving visible traces.

2. Notwithstanding the provisions of Article 1 (c) of these Regulations, constituent parts of the container which, for practical reasons, have to include empty spaces (for example, between the partitions of a double wall) shall be permitted. In order that the said spaces cannot be used to conceal goods :
  - (i) where it covers the full height from floor to roof, or, in other cases, where the space between it and the outer wall is completely enclosed, the lining inside the container shall be so fitted that it cannot be removed and replaced without leaving obvious traces, and
  - (ii) where a lining is of less than full height and the spaces between the lining and the outer wall are not completely enclosed, and in all other cases where spaces occur in the construction of a container, the number of such spaces shall be kept to a minimum and these spaces shall be readily accessible for Customs inspection.

### Article 3

#### **Containers capable of being folded or dismantled**

Containers capable of being folded or dismantled shall be subject to the provisions of Articles 1 and 2 of these Regulations; in addition, they shall be fitted with a bolting system which locks the various parts together once the container has been erected. This bolting system must be capable of being sealed by the Customs if it is on the outside of the container when the latter has been erected.

### Article 4

#### **Sheeted containers**

1. Where applicable, the provisions of Articles 1, 2 and 3 of these Regulations shall apply to sheeted containers. In addition, these containers shall conform to the provisions of this Article.
2. The sheet shall be either of strong canvas or of plastic-covered or rubberized cloth, which shall be of sufficient strength and unstretchable. It shall be in good condition and made up in such a way that once the closing device has been secured, it is impossible to gain access to the load without leaving visible traces.
3. If the sheet is made up of several pieces, their edges shall be folded into one another and sewn together with two seams at least 15 mm apart. These seams shall be made as shown in sketch No. 1 appended to these Regulations; however, where in the case of certain parts of the sheet (such as flaps and reinforced corners) it is not possible to assemble the pieces in that way, it shall be sufficient to fold the edge of the top section and make the seams as shown in sketch No. 2 or 2 (a) appended to these Regulations. One of the seams shall be visible only from the inside and the colour of the thread used for that seam shall be clearly different from the colour of the sheet itself and from the colour of the thread used for the other seam. All seams shall be

machine-sewn.

4. If the sheet is of plastic-covered cloth, and is made up of several pieces, the pieces may alternatively be welded together in the manner shown in sketch No. 3 appended to these Regulations. The edges of the pieces shall overlap by at least 15 mm. The pieces shall be fused together over the whole width of the overlap. The edge of the outer sheet shall be covered with a band of plastic material at least 7 mm wide, affixed by the same welding process. The plastic band and a width of at least 3 mm on each side shall have a well-marked uniform relief stamped on it. The pieces shall be welded in such a way that they cannot be separated and rejoined without leaving visible traces.
5. Repairs shall be made in accordance with the method described in sketch No. 4 appended to these Regulations; the edges shall be folded into one another and sewn together with two visible seams at least 15 mm apart; the colour of the thread visible from the inside shall be different from that of the thread visible from the outside and from that of the sheet itself; all seams shall be machine-sewn. When a sheet which has been damaged near the edges is repaired by replacing the damaged part by a patch, the seam can also be made in accordance with the provisions of paragraph 3 of this Article and sketch No. 1 appended to these Regulations. Sheets of plastic-covered cloth may alternatively be repaired in accordance with the method described in paragraph 4 of this Article, but in that case the plastic band must be affixed to both sides of the sheet, the patch being fitted on the inside of the sheet.
6. The sheet shall be fixed to the container in strict compliance with the conditions set forth in Article 1 (a) and (b) of these Regulations. The following systems can be used :

(a)The sheet can be secured by :

- (i) metal rings fixed to the containers;
- (ii) eyelets let into the edge of the sheet; and
- (iii) a fastening passing through the rings above the sheet and visible from the outside for its entire length.

The sheet shall overlap solid parts of the container by at least 250 mm, measured from the centre of the securing rings, unless the system of construction of the container in itself prevents all access to the goods.

(b)When any edge of a sheet is to be permanently secured to a container, the two surfaces shall be joined together without a break and shall be held in place by strong devices.

(c)When a sheet locking system is used it shall in locked position join the sheet tightly to the outside of the container (as an example see sketch No. 6).

7. The sheet shall be supported by an adequate superstructure (uprights, sides, arches, slats, etc.).
8. The spaces between the rings and the spaces between the eyelets shall not exceed 200 mm. The spaces may, however, be greater but shall not exceed 300 mm between rings and eyelets on either side of the upright if the construction of the container and the sheet is such as to prevent all access to the interior of the container. The eyelets shall be reinforced.
9. The following fastenings shall be used :
  - (a) steel wire rope of at least 3 mm diameter; or
  - (b) a rope of hemp or sisal of at least 8 mm diameter encased in a transparent unstretchable plastic sheath.

Wire ropes may have a transparent unstretchable plastic sheath.
10. Each rope shall be in one piece and have a hard metal end-piece at each end. The fastener of each metal end-piece shall include a hollow rivet passing through the rope so as to allow the introduction of the thread or the strap of the Customs seal. The rope shall remain visible on either side of the hollow rivet so that it is possible to ensure that the rope is in one piece (see sketch No. 5 appended to the Regulations). In cases where the sheet has to be fixed to the frame in a system of construction which otherwise complies with the provisions of paragraph 6 (a) of this Article, a thong can be used as fastening (an example of such a system of construction is given in sketch No. 7 appended to these Regulations). The thong has to comply with the requirements stipulated in paragraph 11 (a) (iii) with regard to material, dimensions and shape.
11. At the openings in the sheet, used for loading and unloading, the two surfaces shall be joined together. The following systems can be used :
  - (a) The two edges of the sheet shall have an adequate overlap. They shall also be fastened by :
    - (i) a flap sewn or welded in accordance with paragraphs 3 and 4 of this Article;
    - (ii) rings and eyelets meeting the conditions of paragraph 8 of this Article; the rings shall be manufactured of metal; and
    - (iii) a thong made of appropriate material, in one piece and unstretchable, at least 20 mm wide and 3 mm thick, passing through the rings and holding together the two edges of the sheet and the flap; the thong shall be secured inside the sheet and fitted either with
      - an eyelet to take the rope mentioned in paragraph 9 of this Article, or
      - an eyelet which can be attached to a metal ring mentioned in

paragraph 6 of this Article and be secured by the rope mentioned in paragraph 9 of this Article.

A flap shall not be required if a special device, such as a baffle plate, is fitted, which prevents access to the container without leaving obvious traces.

Neither shall a flap be required for containers with sliding sheets.

(b) A special locking system holding the edges of the sheets tightly locked when the container is closed and sealed. The system shall be provided with an opening through which a metal ring mentioned in paragraph 6 of this Article can pass and be secured by the rope mentioned in paragraph 9 of this Article (see sketch No. 8 appended to these Regulations).

12. The identification marks, which must appear on the container in accordance with Annex 1, and the approval plate provided for in Annex 5, shall in no circumstances be covered by the sheet.

## Article 5

### Containers with sliding sheets

1. Where applicable, the provisions of Articles 1, 2, 3 and 4 of these Regulations shall apply to containers with sliding sheets. In addition, these containers shall conform to the provisions of this article.
2. The sliding sheets, floor, doors and all other constituent parts of the container shall fulfill either the requirements in Article 4, paragraphs 6, 8, 9 and 11 of these Regulations or the requirements set out in (i) to (vi) below.
  - (i) The sliding sheets, floor, doors and all other constituent parts of the container shall be assembled either by means of devices which cannot be removed and replaced from the outside without leaving obvious traces, or by such methods as will produce a structure which cannot be modified without leaving obvious traces.
  - (ii) The sheet shall overlap the solid parts at the top of the container by at least  $\frac{1}{4}$  of the actual distance between the tensioning straps. The sheet shall overlap the solid parts at the bottom of the container by at least 50 mm. The horizontal opening between the sheet and the solid parts of the container may not exceed 10 mm measured perpendicular to the longitudinal axis of the container at any place when the container is secured and sealed for Customs purposes.
  - (iii) The sliding sheet guidance, sliding sheet tension devices and other movable parts shall be assembled in such a way that when closed, and Customs sealed, doors and other movable parts cannot be opened or closed from the outside without leaving obvious traces. The sliding sheet guidance, sliding



sheet tension devices and other movable parts shall be assembled in such a way that it is impossible to gain access to the container without leaving obvious traces once the closing devices has been secured. An example of such a system of construction is given in sketch No. 9 appended to these Regulations.

- (iv) The horizontal distance between the rings, used for Customs purpose, on the solid parts of the container shall not exceed 200 mm. The space may, however, be greater but shall not exceed 300 mm between the rings on either side of the upright if the construction of the container and the sheets is such as preventing all access to the container. In any case, the conditions laid down in (ii) above shall be complied with.
- (v) The distance between the tensioning straps shall not exceed 600 mm.
- (vi) The fastenings used to secure the sheets to the solid parts of the container shall fulfil the requirements in Article 4, paragraph 9 of these Regulations.

## Article 6

### **Containers with a sheeted sliding roof**

1. Where applicable, the provisions of Articles 1, 2, 3, 4 and 5 of these Regulations shall apply to containers with a sheeted sliding roof. In addition, these containers shall conform to the provisions of this Article.
2. The sheeted sliding roof shall fulfil the requirements set out in (i) to (iii) below.
  - (i) The sheeted sliding roof shall be assembled either by means of devices which cannot be removed and replaced from the outside without leaving obvious traces, or by such methods as will produce a structure which cannot be modified without leaving obvious traces.
  - (ii) The sliding roof sheet shall overlap with the solid part of the roof at the front side of the container, so that the roof sheet cannot be pulled over the top edge of the upper cantrail. In the length of the container, at both sides, in the hem of the roof sheet, a pre-stressed steel cable shall be inserted in such a way that it cannot be removed and re-inserted without leaving obvious traces. The roof sheet shall be secured to the sliding carriage in such a way that it cannot be removed and re-secured without leaving obvious traces.
  - (iii) The sliding roof guidance, the sliding roof tension devices and other movable parts shall be assembled in such a way that when closed, and Customs sealed, doors, roof and other movable parts cannot be opened or closed from the outside without leaving obvious traces. The sliding roof guidance, sliding roof tension devices and other movable parts shall be assembled in such a way that it is impossible to gain access to the container without leaving obvious traces once the closing devices have been secured.

An example of a possible system of construction is shown in sketch No. 10, appended to these Regulations.

Annex 4 - Sketch No. 1

SHEET MADE OF SEVERAL PIECES

Sewn together by means of seams

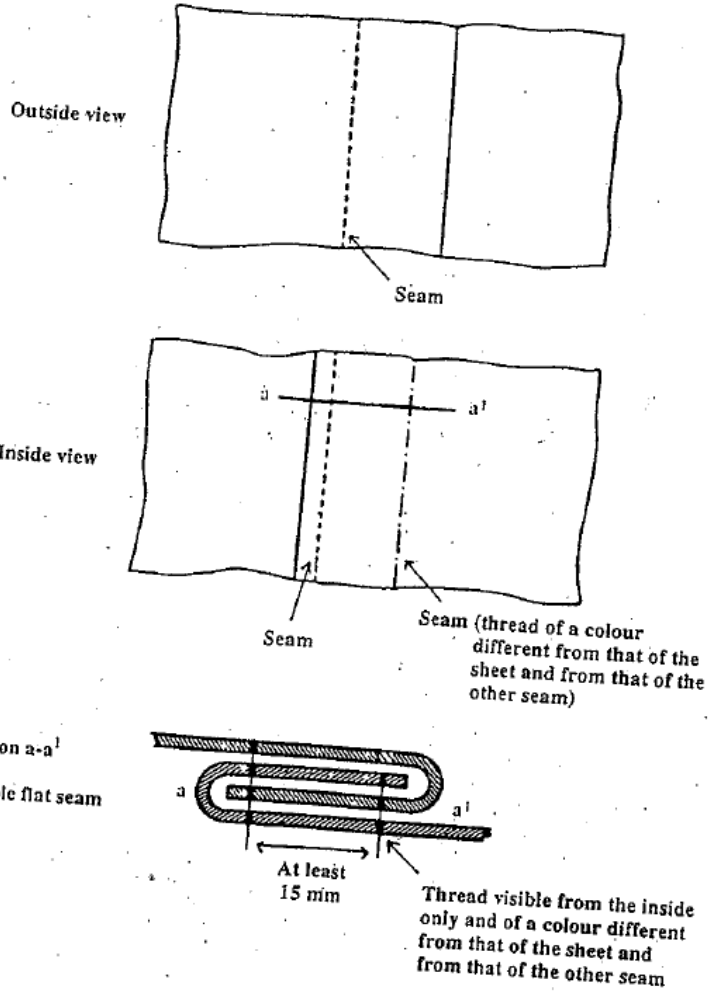

Annex 4 - Sketch No. 2

SHEET MADE OF SEVERAL PIECES

Corner seam

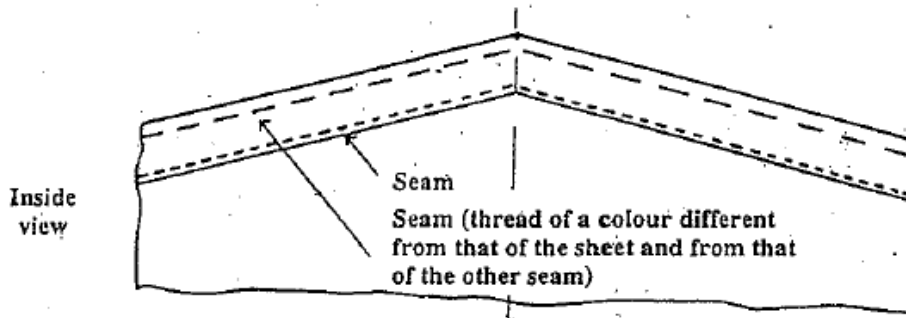
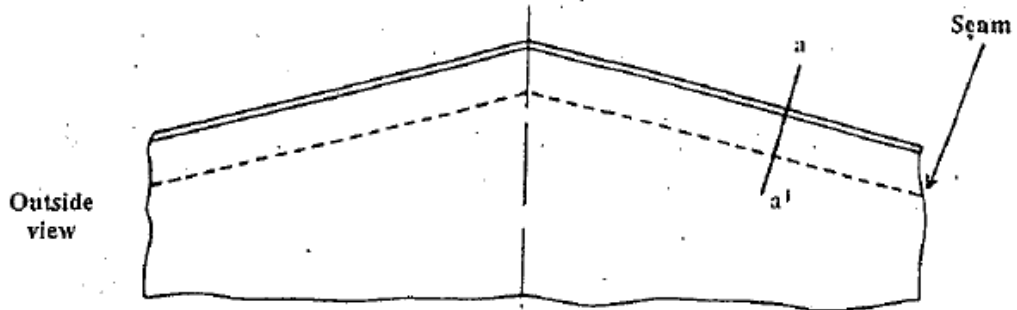

Section a-a'

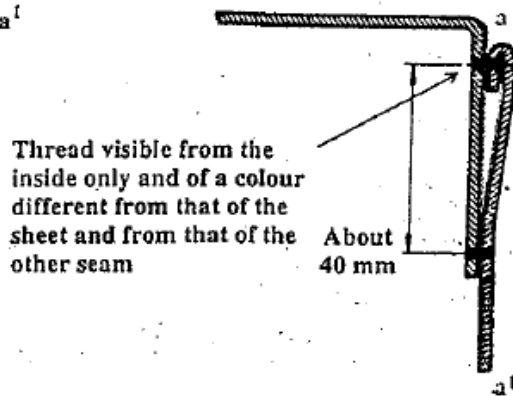

Annex 4 - Sketch No. 2(a)

SHEET MADE OF SEVERAL PIECES

Corner seam

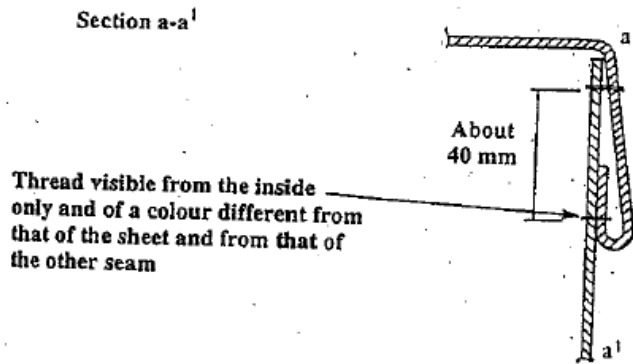
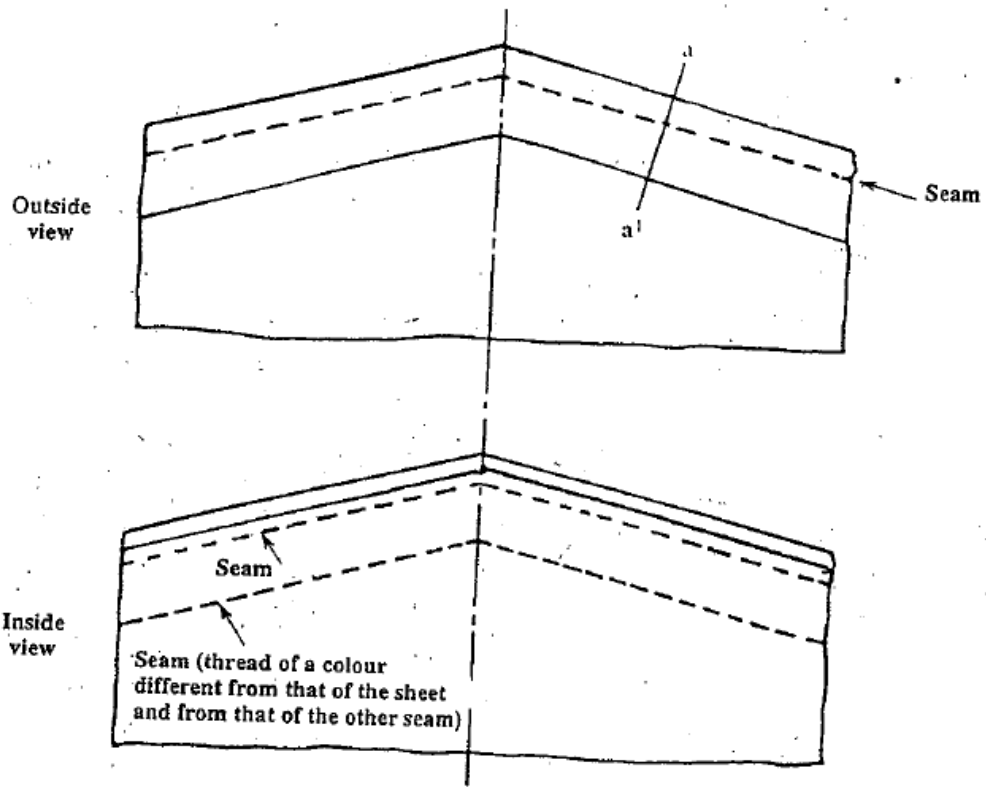

Annex 4 - Sketch No. 3

SHEET MADE OF SEVERAL PIECES

Welded together

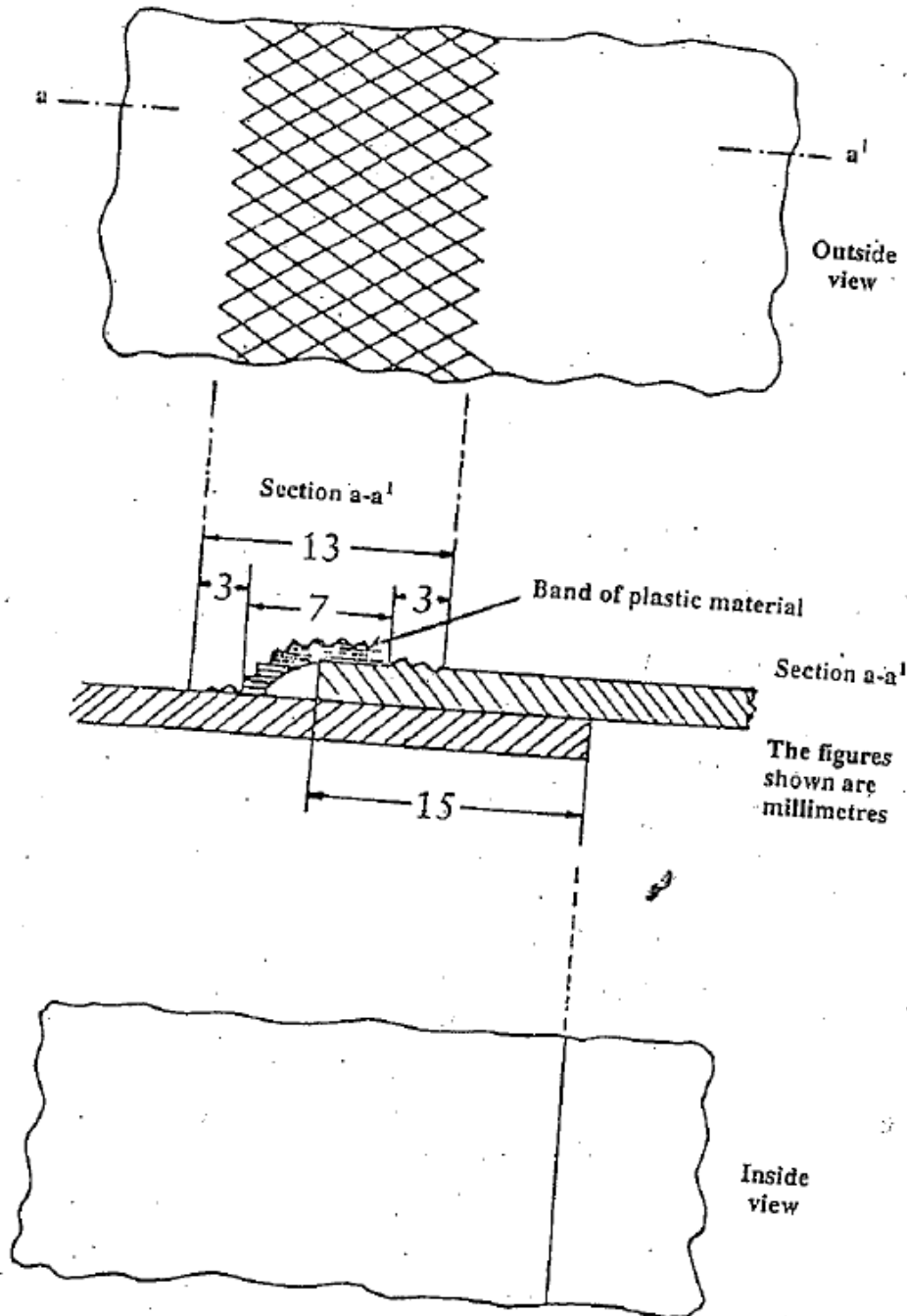

Annex 4 - Sketch No. 4

REPAIR OF THE SHEET

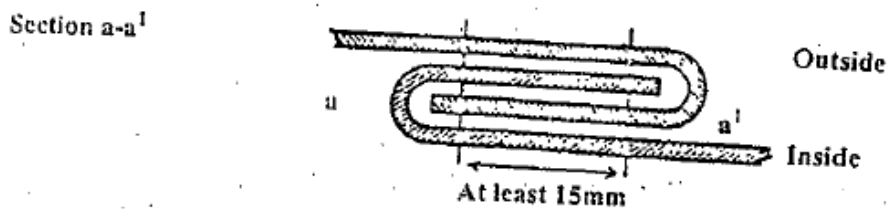
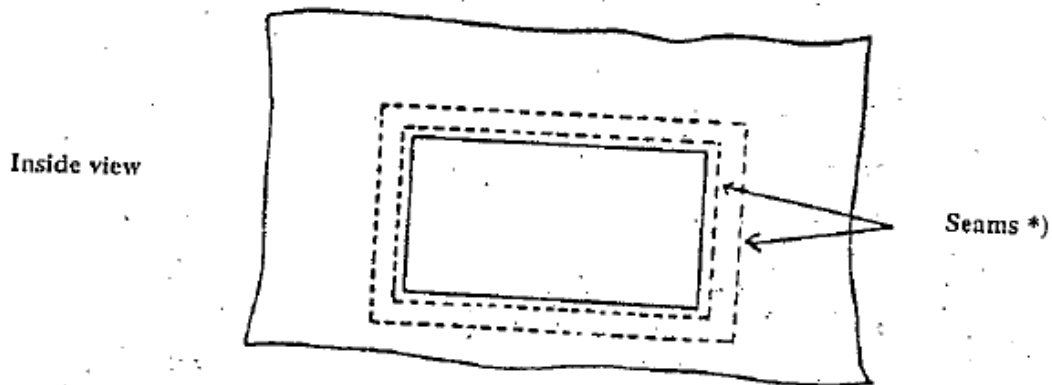
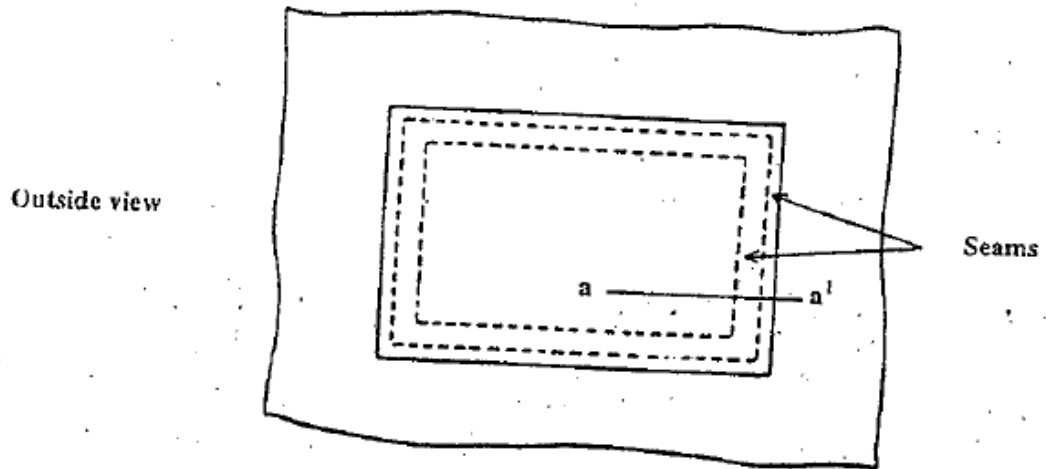

\*) Threads visible from the inside shall be of a colour different from that of the threads visible from the outside and from that of the sheet

Annex 4 - Sketch No. 5

SPECIMEN OF END-PIECE

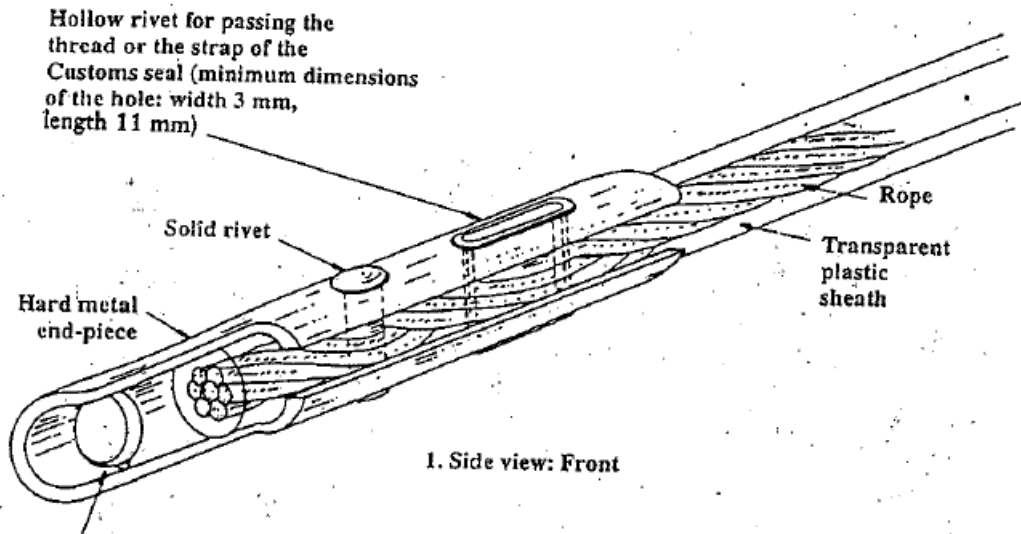

Hole for closing by carrier

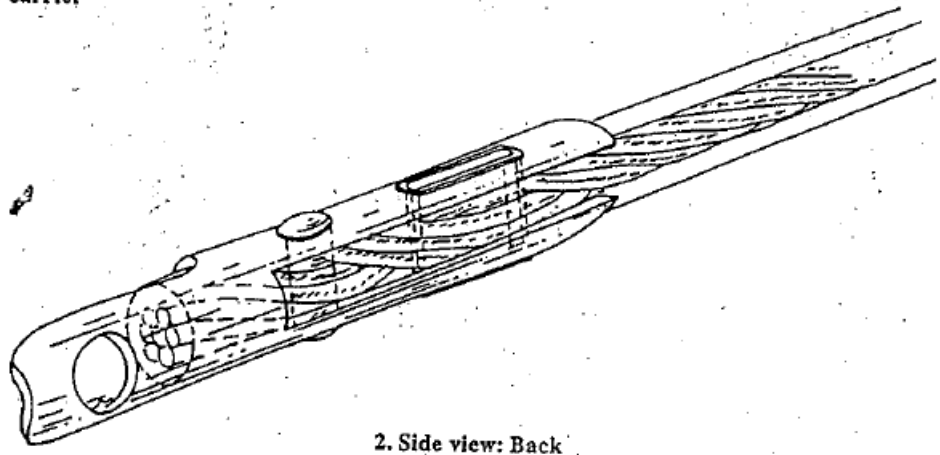

EXAMPLE OF SHEET LOCKING SYSTEM

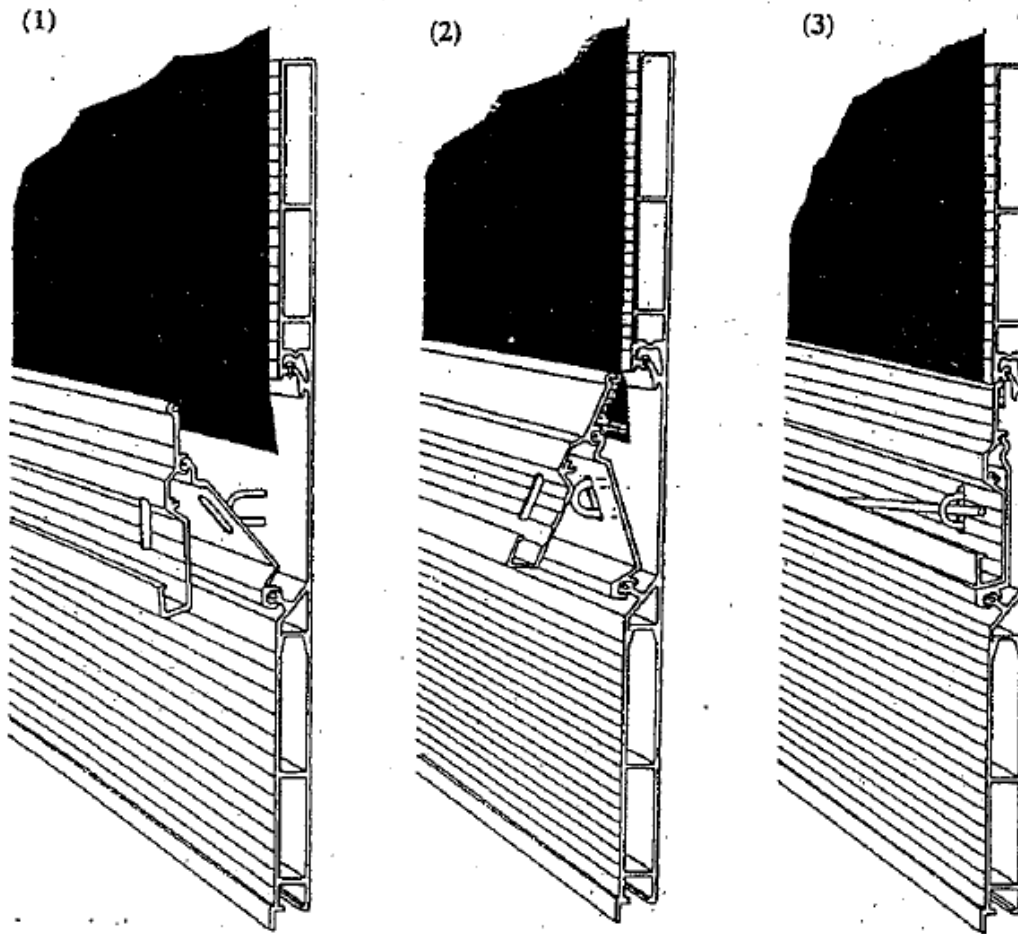

Description

This sheet locking system is acceptable provided that it is fitted with at least one metal ring at each gate end. The openings through which the ring passes are oval and of a size just sufficient to allow the ring to pass through it. The visible part of the metal ring does not protrude more than twice the maximum thickness of the fastening rope when the system is locked.



Annex 4 - Sketch No. 7

EXAMPLE OF SHEET FIXED TO SPECIAL-SHAPED FRAME

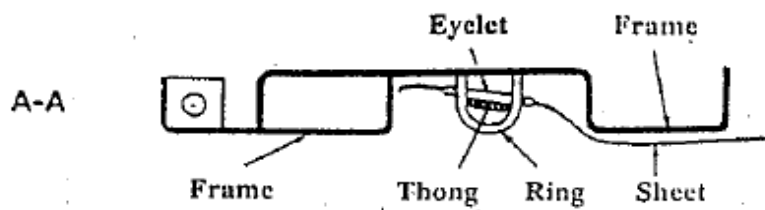
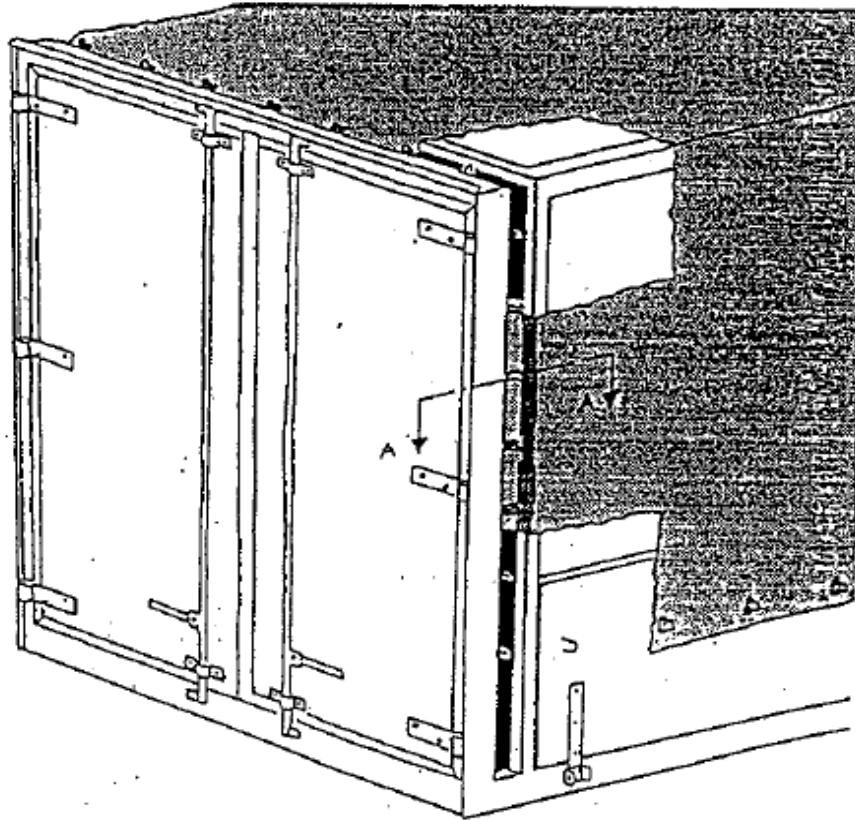

Description

This fastening device of the sheet to the container is acceptable provided that the rings are recessed in the profile and do not protrude more than the maximum depth of the profile. The width of the profile shall be as narrow as possible.

Annex 4 - Sketch No. 8

SHEET LOCKING SYSTEM AT OPENINGS FOR LOADING AND UNLOADING

(Description see next page)

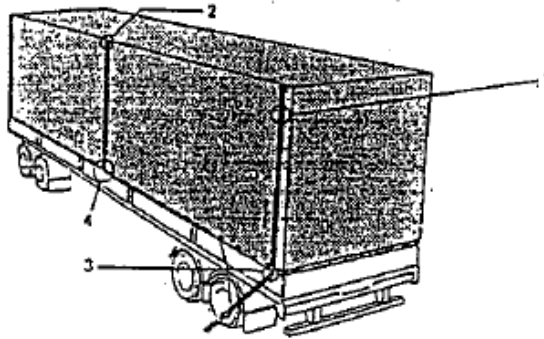

Sketch No.8.1

Sketch No. 8.3

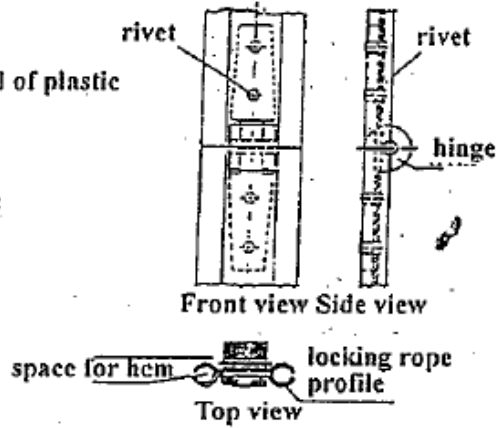
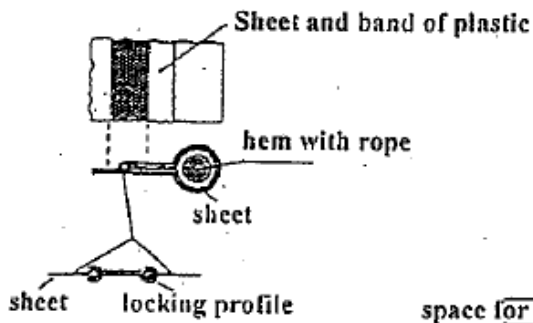

Sketch No.8.2

Sketch No.8.4

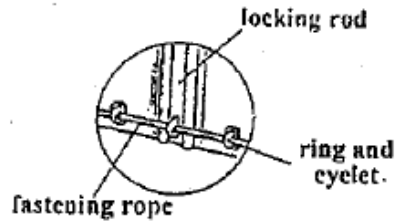
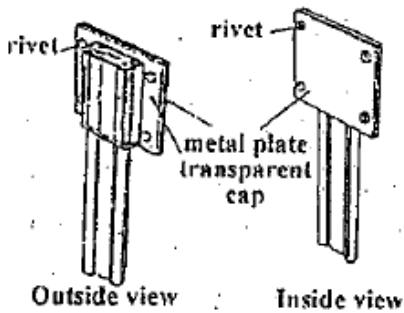

## Description

In this locking system the two edges of the openings in the sheet used for loading and unloading are united by means of an aluminium locking rod. The sheet openings are provided with a hem over its entire length enclosing a rope (see sketch No. 8.1.). This makes it impossible to pull the sheet out of the locking rod's profile. The hem shall be on the outside and welded in accordance with Annex 4, Article 4, paragraph 4 to the Convention. The edges are to be passed into the open profiles on the aluminium locking rod and slid into two parallel longitudinal channels which should be closed at their lower end. When the locking rod is in its upper position the edges of the sheets are united. At the upper end of the opening the locking rod is stopped by a transparent plastic cap fixed by riveting to the sheet (see sketch No. 8.2.). The locking rod consists of two sections, joined by a riveted hinge, to allow folding for easy fitting and removal. This hinge must be designed in such a way as not to allow the removal of the swivel pin once the system is locked (see sketch No. 8.3.). At the lower part of the locking rod is an opening through which the ring passes. The opening is oval and of a size just sufficient to allow the ring to pass through it (see sketch No. 8.4.). The fastening rope will be pulled through this ring to secure the locking rod.

## Annex 4 – Sketch No. 9

### EXAMPLE OF A CONSTRUCTION OF A CONTAINER WITH SLIDING SHEETS

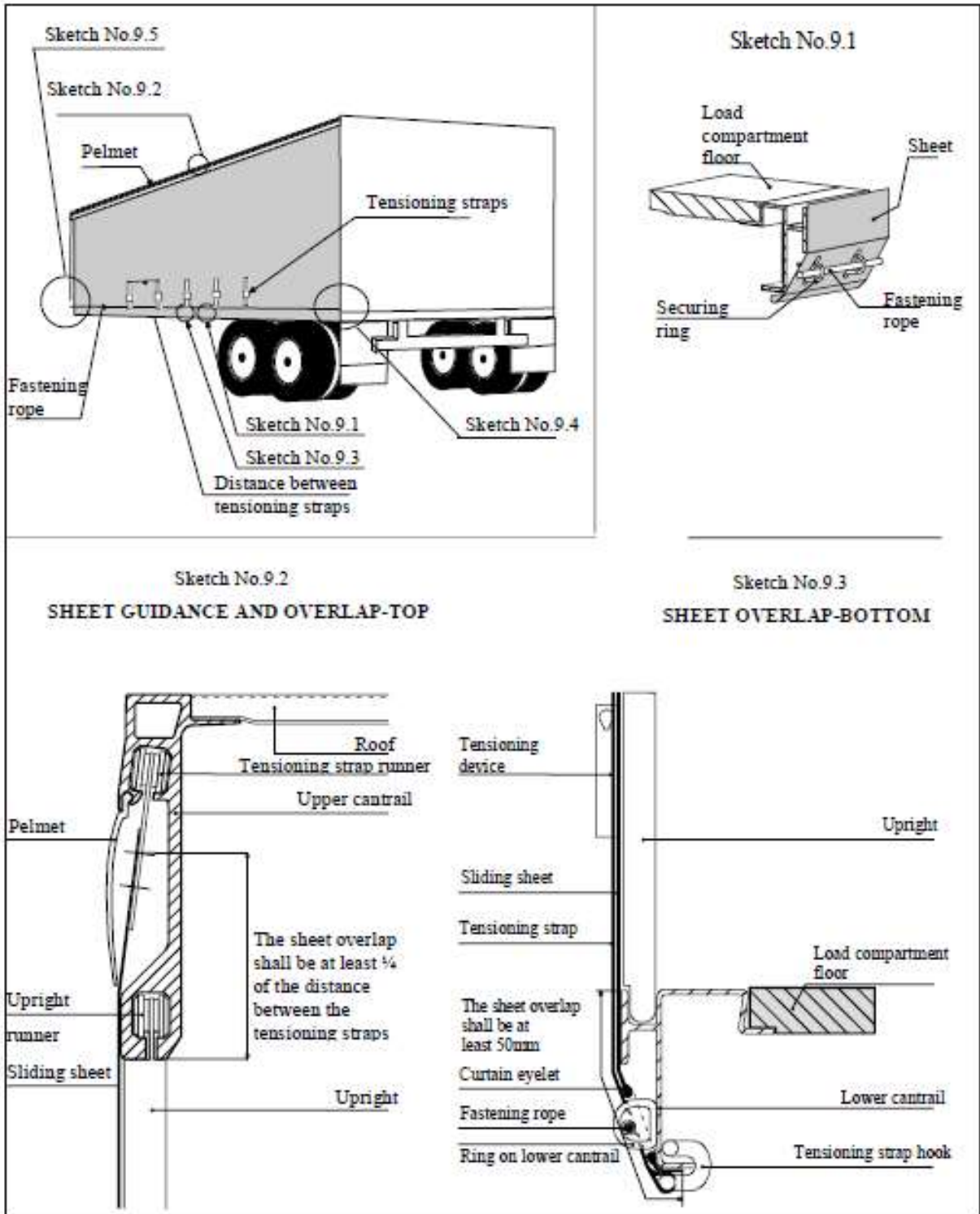

Sketch No. 9.4

To tighten the sliding sheets in the horizontal direction, a ratchet gear is used (normally at the rear end of the container). This sketch shows two examples, (a) and (b), of how the ratchet or gearbox may be secured.

(a) Ratchet securing

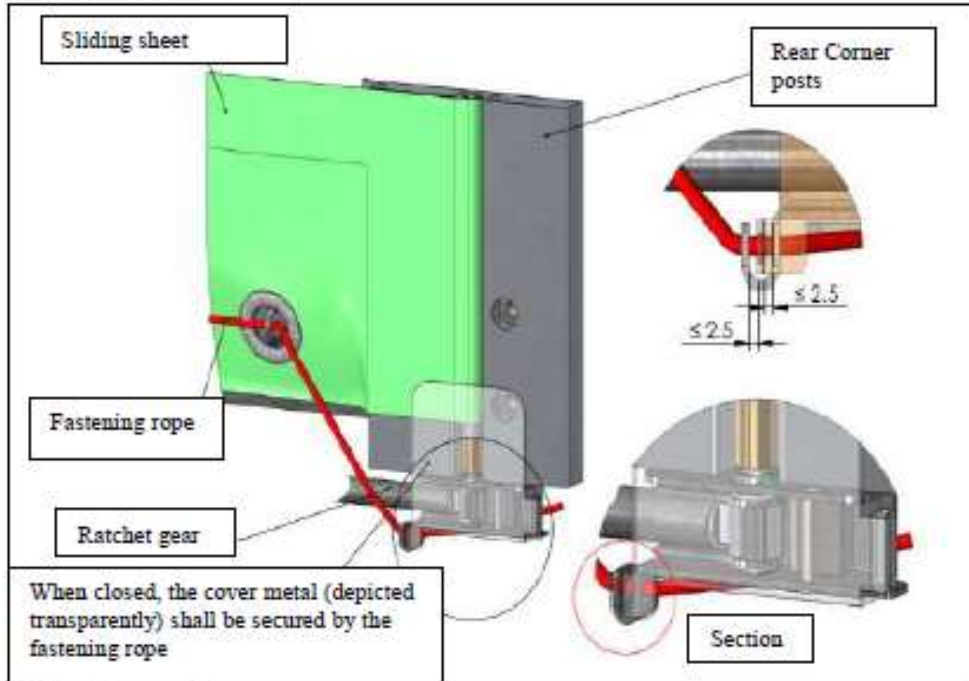

(b) Gearbox securing

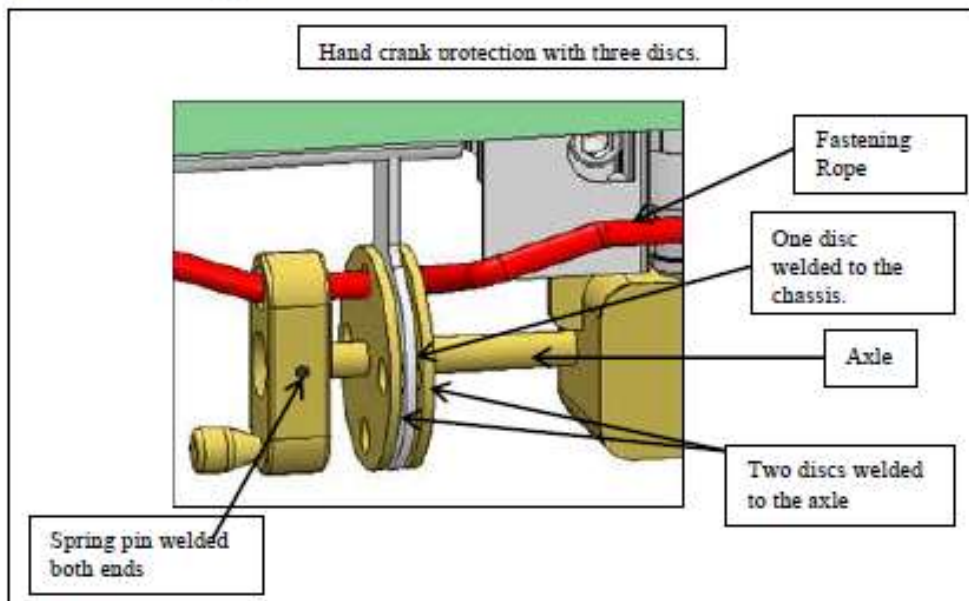

Sketch No. 9 continued

Sketch No. 9.5

To fix the sliding sheet on the other side (normally the front of the container), the following systems, (a) or (b), may be used.

(a) Cover metal

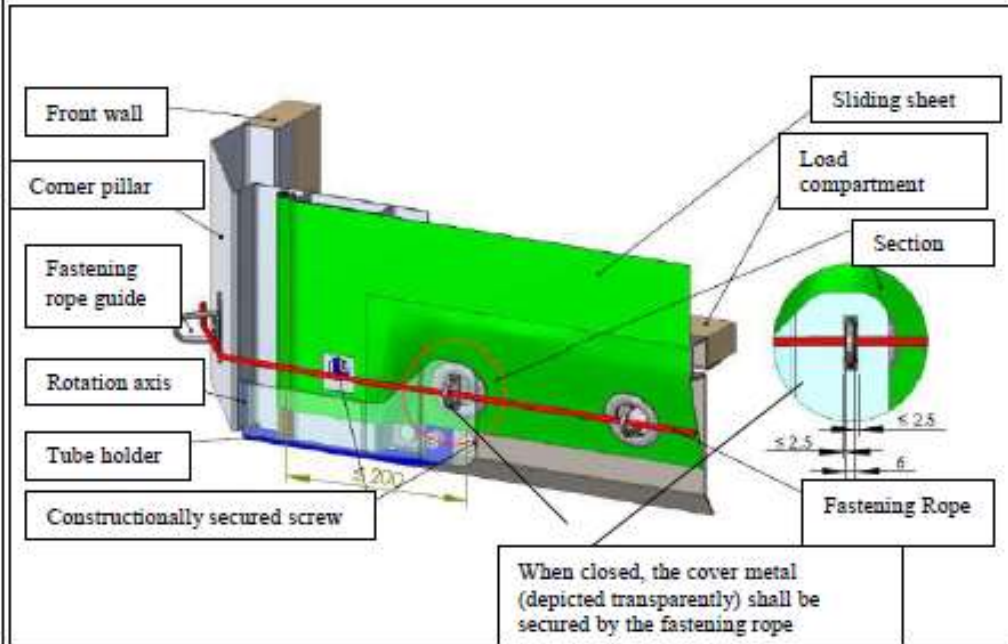

(b) Narrow oval eyelet, anti-lifting system for the tensioning tube

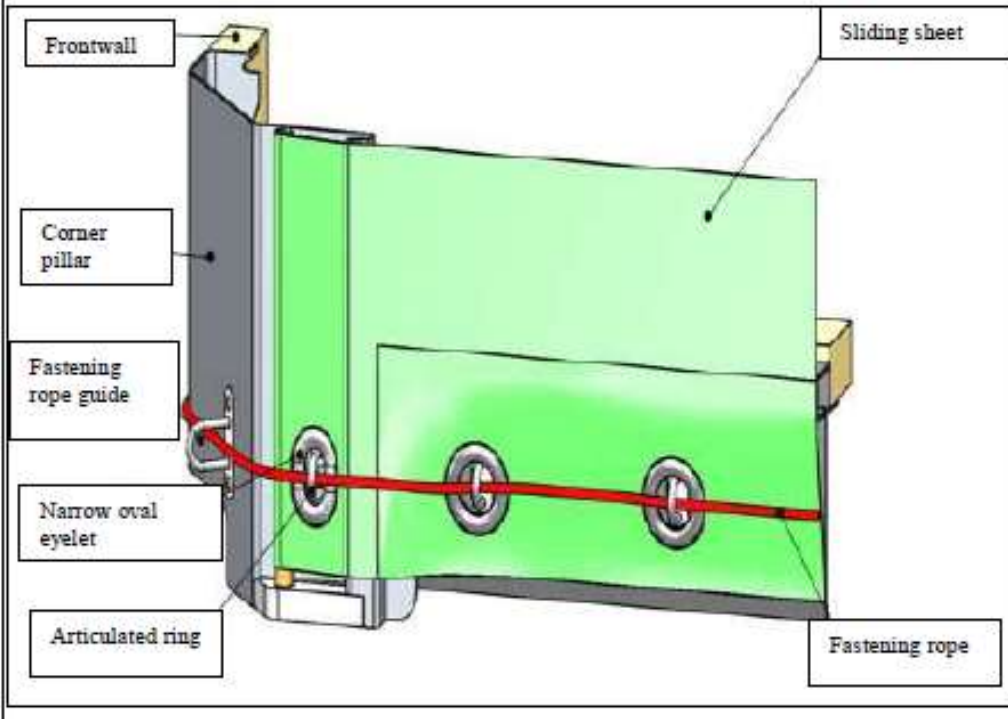

## Annex 4 – Sketch No. 10

### EXAMPLE OF A CONSTRUCTION OF A CONTAINER WITH A SHEETED SLIDING ROOF

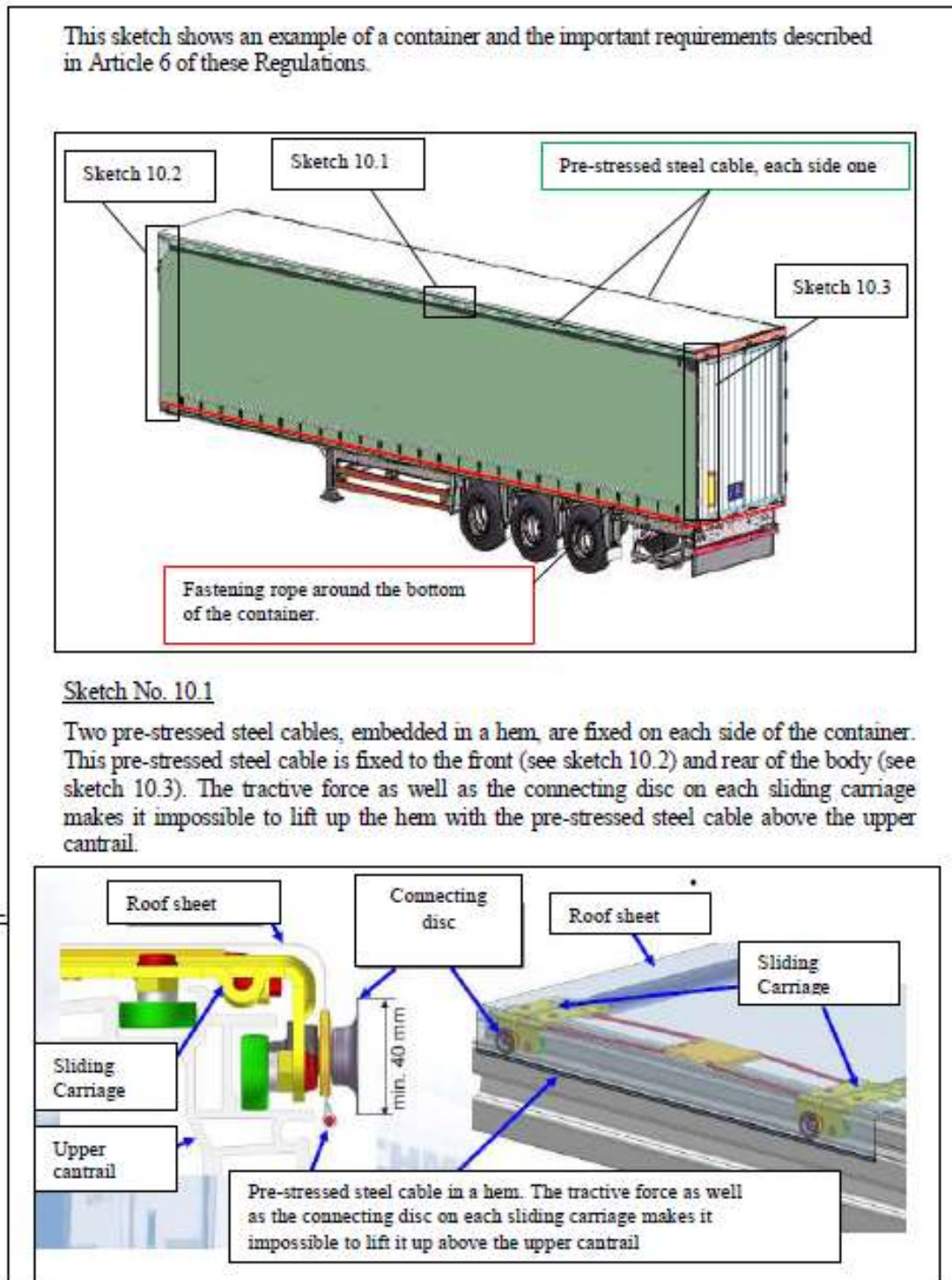

Sketch No. 10 continued

Sketch No.10.2

The sliding roof sheet shall overlap with the solid part of the roof at the front side of the container, so that the roof sheet cannot be pulled over the top edge of the upper cantrail

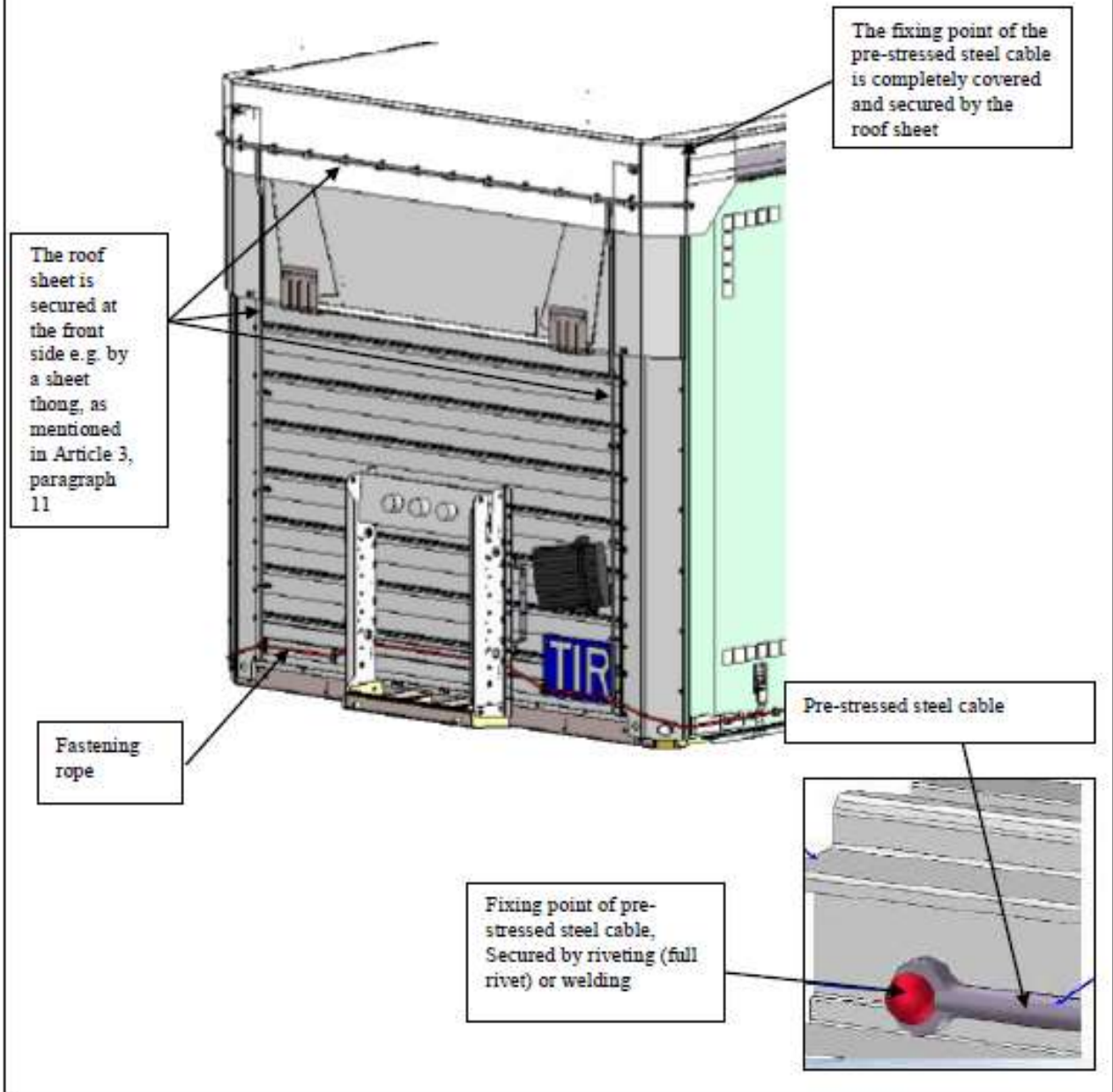



Sketch No.10.3

At the rear, a special device, such as a baffle plate, is fitted to the roof, preventing access to the container, without leaving obvious traces when the doors are closed and sealed.

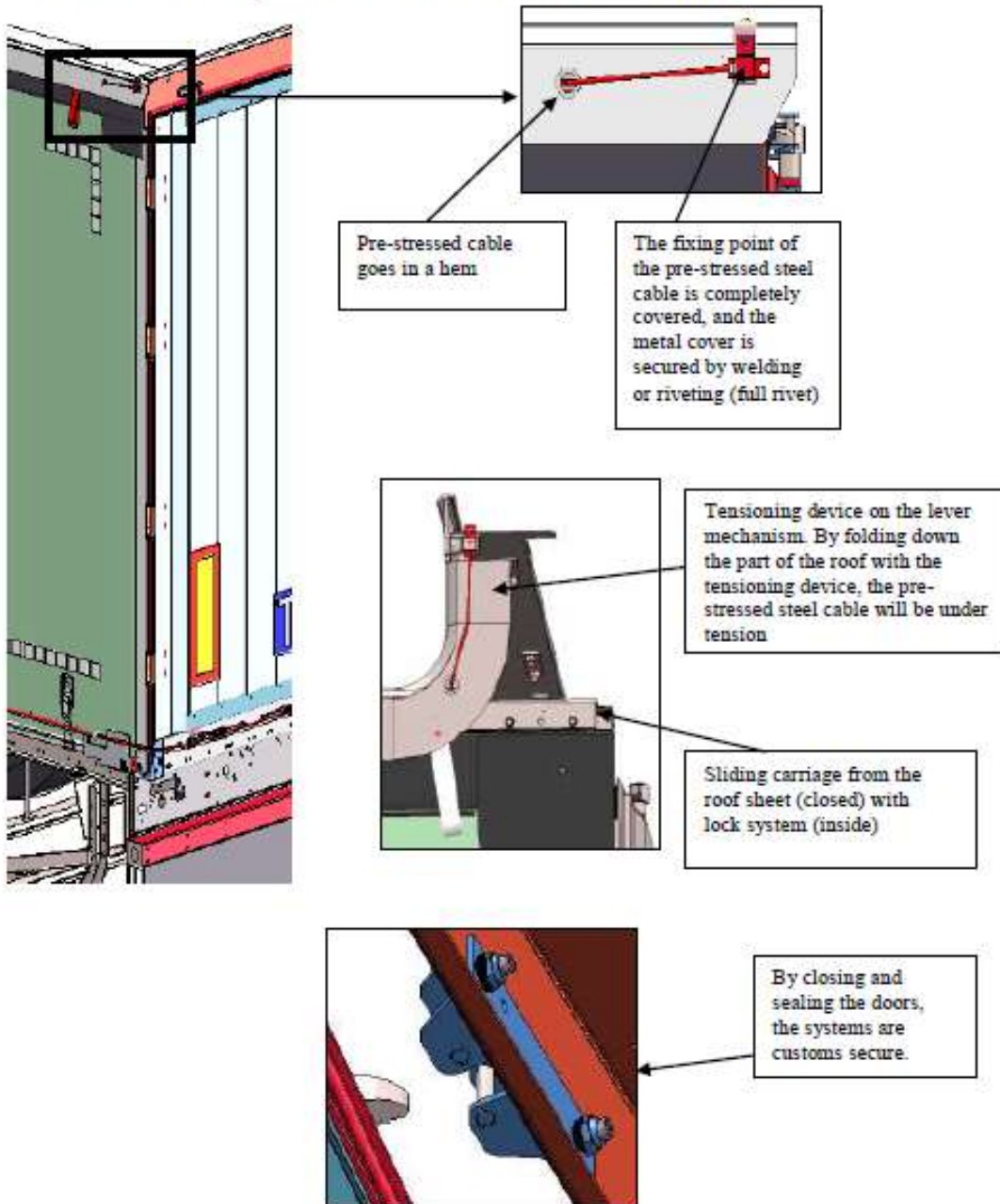

## ANNEX 5

### **Procedures for the approval of containers complying with the technical conditions prescribed in Annex 4**

#### General

1. Containers may be approved for the transport of goods under Customs seal either :
  - (a) at the manufacturing stage, by design type (procedure for approval at the manufacturing stage); or
  - (b) at a stage subsequent to manufacture, either individually or in respect of a specified number of containers of the same type (procedure for approval at a stage subsequent to manufacture).

#### Provisions common to both approval procedures

2. The competent authority responsible for granting approval shall issue to the applicant, after approval, a certificate of approval valid, as the case may be, either for an unlimited series of containers of the approved type or for a specified number of containers.
3. The beneficiary of approval shall affix an approval plate to the approved container or containers before their use for the transport of goods under Customs seal.
4. The approval plate shall be affixed permanently and in a clearly visible place adjacent to any other approval plate issued for official purposes.
5. The approval plate, conforming the model No. 1 reproduced in Appendix 1 to this Annex, shall take the form of a metal plate measuring not less than 20 cm by 10 cm. The following particulars shall be stamped into or embossed on the plate or indicated on its surface in any other permanent and legible way, in at least the English or the French language :
  - (a) the words "Approved for transport under Customs seal";
  - (b) an indication of the country in which approval was granted either by name, or by means of the ISO alpha-2 country code provided for in International Standard ISO 3166, or by the distinguishing sign used to indicate the country of registration of motor vehicles in international road traffic, and the number (figures, letters, etc.) of the certificate of approval and the year of approval (e.g. "NL/26/73" means "Netherlands, certificate of approval No. 26, issued in 1973");
  - (c) the serial number assigned to the container by the manufacturer (manufacturer's

number);

(d)if the container has been approved by type, the identification numbers or letters of the type of container.

6. If a container no longer complies with the technical conditions prescribed for its approval, it shall, before it can be used for the transport of goods under Customs seal, be restored to the condition which had justified its approval, so as to comply again with the said technical conditions.

7. If the essential characteristics of a container are changed, the container shall cease to be covered by the approval and shall be reapproved by the competent authority before it can be used for the transport of goods under Customs seal.

*Special provisions for approval by design type at the manufacturing stage*

8. Where the containers are manufactured by type series, the manufacturer may apply to the competent authority of the country of manufacture for approval by design type.

9. The manufacturer shall state in his application the identification numbers or letters which he assigns to the type of container to which his application for approval relates.

10. The application shall be accompanied by drawings and a detailed design specification of the container type to be approved.

11. The manufacturer shall give an undertaking in writing that he will :

(a)produce to the competent authority such containers of the type concerned as that authority may wish to examine;

(b)permit the competent authority to examine further units at any time during the production of the type series concerned;

(c)advise the competent authority of any change, of whatever magnitude, in the design or specification before proceeding with such change;

(d)mark the containers in a visible place with, in addition to the markings required on the approval plate, the identification numbers or letters of the design type and the serial number of the container in the type series (manufacturer's number);

(e)keep a record of containers manufactured to the approved design type.

12. The competent authority shall state what changes, if any, must be made to the proposed design type so that approval may be granted.

13. No type-approval by design type shall be granted unless the competent

authority has satisfied itself by examination of one or more containers manufactured to the design type concerned that containers of that type comply with the technical conditions prescribed in Annex 4.

14. When a container type is approved there shall be issued to the applicant a single certificate of approval conforming to model No. II reproduced in Appendix 2 to this Annex and valid for all containers manufactured in conformity with the specifications of the type so approved. Such certificate shall entitle the manufacturer to affix to every container of the type series an approval plate in the form prescribed in paragraph 5 of this Annex.

*Special provisions for approval at a stage subsequent to manufacture*

15. If approval has not been applied for at the manufacturing stage, the owner, the operator, or the representative of either, may apply for approval to the competent authority to which he is able to produce the container or containers and for which he seeks approval.
16. An application for approval submitted under paragraph 15 of this Annex shall state the serial number (manufacturer's number) placed on each container by the manufacturer.
17. When the competent authority has ascertained that the container or containers comply with the technical conditions prescribed in Annex 4, by examination of as many containers as it considers necessary, it shall issue a certificate of approval conforming to model No. III reproduced in Appendix 3 to this Annex and valid solely for the number of containers approved. Such certificate, which shall bear the manufacturer's serial number or numbers assigned to the container or containers to which it relates, shall entitle the applicant to affix to each container so approved the approval plate prescribed in paragraph 5 of this Annex.

Appendix 1 to Annex 5

MODEL  
No.1

APPROVAL  
PLATE

(English  
version)

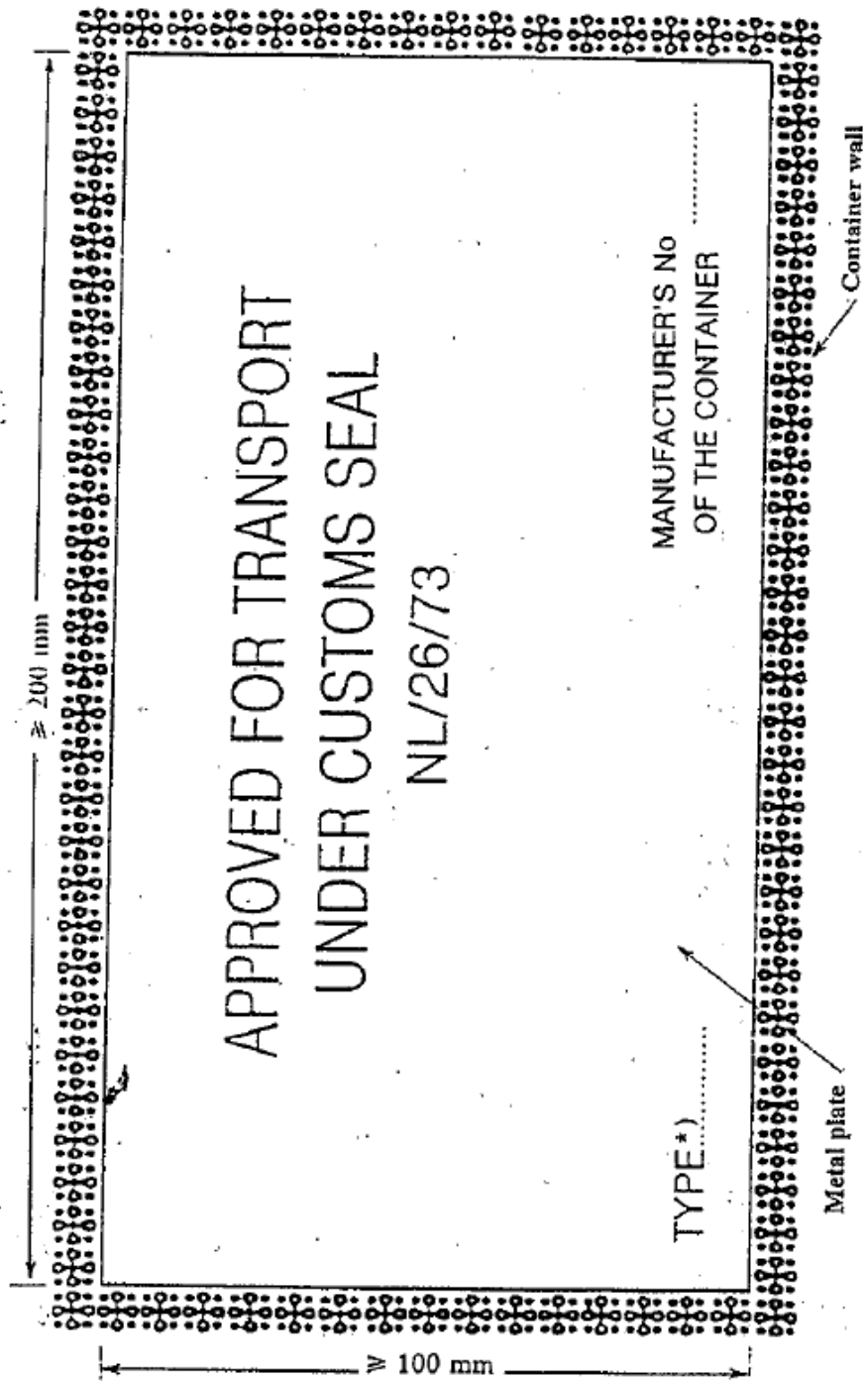

\*) Only in case of approval by design type.

Appendix 1 to Annex 5

MODEL  
No.1

APPROVAL  
PLATE

(French  
version)

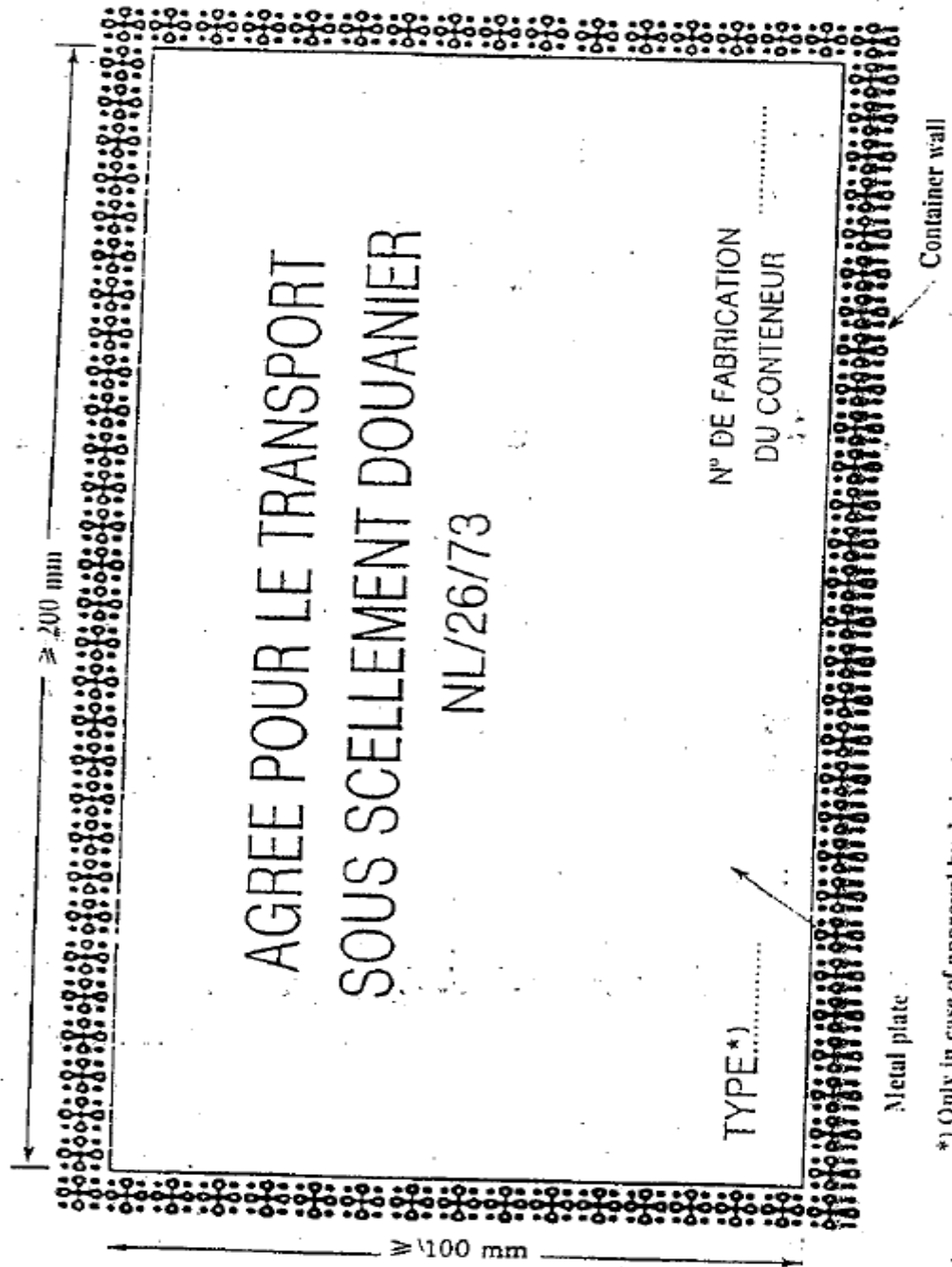

\*) Only in case of approval by design type.

**Appendix 2 to Annex 5**  
**MODEL No. II**  
**Customs Convention on Containers, 1972**  
Certificate of approval by design type

1. Certificate No.(\*).....
2. This is to certify that the container design type described below has been approved and that containers manufactured to this type can be accepted for the transport of goods under Customs seal.
3. Kind of container .....
4. Identification number or letters of the design type .....
5. Identification number of the working drawings .....
6. Identification number of the design specifications .....
7. Tare weight .....
8. External dimensions in centimetres .....
9. Essential characteristics of structure (nature of materials, kind of construction, etc.)  
.....  
.....  
.....  
.....
10. This certificate is valid for all containers manufactured in conformity with the drawings and specifications referred to above.
11. Issued to .....  
(manufacturer's name and address)  
who is authorized to affix an approval plate to each container of the approved design type manufactured by him,  
at ..... on ..... 19 ....  
(place) (date)  
by .....  
(signature and stamp of issuing service or organization)

(See notice overleaf)

---

(\*) Insert the letters and figures, which are to be marked on the approval plate (see paragraph 5 (b) of Annex 5 to the Customs Convention on Containers, 1972).

## IMPORTANT NOTICE

(Annex 5, paragraphs 6 and 7,  
to the Customs Convention on Containers, 1972)

6. If a container no longer complies with the technical conditions prescribed for its approval, it shall, before it can be used for the transport of goods under Customs seal, be restored to the condition which had justified its approval, so as to comply again with the said technical conditions.
7. If the essential characteristics of a container are changed, the container shall cease to be covered by the approval and shall be reapproved by the competent authority before it can be used for the transport of goods under Customs seal.



**Appendix 3 to Annex 5**  
**MODEL No. III**

**Customs Convention on Containers, 1972**

Certificate of approval granted at a stage subsequent to manufacture

1. Certificate No.(\*) .....
2. This is to certify that the container (containers) specified below has (have) been approved for the transport of goods under Customs seal.
3. Kind of container(s) .....
4. Serial number(s) assigned to the container(s) by the manufacturer .....  
.....
5. Tare weight .....
6. External dimensions in centimetres .....
7. Essential characteristics of structure (nature of materials, kind of construction, etc.)  
.....  
.....  
.....  
.....
8. Issued to .....  
(manufacturer's name and address)  
who is authorized to affix an approval plate to the above-mentioned container(s)  
  
at ..... on ..... 19 ....  
(place) (date)  
  
by .....  
(signature and stamp of issuing service or organization)

(See notice overleaf)

(\*) Insert the letters and figures, which are to be marked on the approval plate (see paragraph 5 (b) of Annex 5 to the Customs Convention on Containers, 1972).

### IMPORTANT NOTICE

(Annex 5, paragraphs 6 and 7,  
to the Customs Convention on Containers, 1972)

6. If a container no longer complies with the technical conditions prescribed for its approval, it shall, before it can be used for the transport of goods under Customs seal, be restored to the condition which had justified its approval, so as to comply again with the said technical conditions.
7. If the essential characteristics of a container are changed, the container shall cease to be covered by the approval and shall be reapproved by the competent authority before it can be used for the transport of goods under Customs seal.

## ANNEX 6

### Explanatory Notes

#### *Introduction*

- (i) In accordance with the provisions of Article 13 of the present Convention, the Explanatory Notes interpret some provisions of the present Convention and of its Annexes.
- (ii) The Explanatory Notes do not modify the provisions of the present Convention or of its Annexes but make their contents, meaning and scope more precise.
- (iii) In particular, having regard to the principles laid down by the provisions of Article 12 of the present Convention and of Annex 4 thereto for the approval of containers for transport under Customs seal, the Explanatory Notes specify, where appropriate, the construction techniques to be accepted by the Contracting Parties as complying with those provisions. The Explanatory Notes may also specify which construction techniques, if any, do not comply with those provisions.
- (iv) The Explanatory Notes provide a means of applying the provisions of the present Convention and of its Annexes according to the development of technology and economic requirements.

#### 0. Main text of the Convention

##### 0.1 Article 1

##### Subparagraph (c)(i) - Partially enclosed containers

##### 0.1.(c)(i)-1

The term "partially enclosed", as applied to equipment in Article 1, subparagraph (c)(i), relates to equipment generally consisting of a floor and a superstructure marking off a loading space equivalent to that of a closed container. The superstructure is generally made up of metal members forming the frame of a container. Containers of this type may also comprise one or more lateral or frontal walls. In some cases there is only a roof attached to the floor by uprights. This type of container is used in particular for the carriage of bulky goods (motor cars, for example).

##### Subparagraph (c) - Accessories and equipment of the container

##### 0.1.(c)-1

The term "accessories and equipment of the container" shall cover in particular the following devices, even if they are removable :

- (a) equipment for controlling, modifying or maintaining the

- temperature inside the container;
- (b) small appliances, such as temperature or impact recorders, designed to indicate or record variations in environmental conditions and impact;
- (c) internal partitions, pallets, shelves, supports, hooks, and similar devices used for stowing goods.

#### Subparagraph (c) - Demountable bodies

0.1.(c)-2

The term "demountable body" means a load-compartment which has no means of locomotion and which is designed in particular to be transported upon a road vehicle, the chassis of which, together with the under-framing of the body is especially adapted for this purpose. It covers also a swap-body which is a load-compartment designed especially for combined road and rail transport.

#### 1. Annex 1

#### 1.1 Paragraph 1 - Use of plastic film for identification marks and numbers on containers

1.1-1

For identification marks and numbers on containers to be considered durably marked when plastic film is used, compliance with the following specifications is required :

- (a) a high-quality adhesive shall be used. The film, once applied, shall have a tensile strength lower than its final adhesion so that removal of the film without destroying it is impossible. Film produced by the cast method of production meets these requirements. Film produced by the calendar method of production shall not be used;
- (b) when identification marks and numbers have to be changed, the film to be replaced shall be removed completely prior to the affixing of the new film; placing of new film over an existing film shall not be permitted.

1.1-2

The specifications for the use of plastic film for marking containers set out in subparagraph 1.1-1 of this Explanatory Note do not exclude the possibility of using other durable marking methods.

#### 4. Annex 4

#### 4.2 Article 2

##### Subparagraph 1.(a) - Assembly of constituent parts

##### 4.2.1.(a)-1

- (a) Where joining devices (rivets, screws, bolts and nuts, etc.) are used, a sufficient number of such devices shall be inserted from outside, traverse the assembled constituent parts, protrude inside and there be firmly secured (e.g. riveted, welded, bushed or bolted and swaged or welded on the nut). However, conventional rivets (i.e., rivets whose placing requires handling from both sides of the assembly of constituent parts) may also be inserted from the inside. Notwithstanding the above, container floors may be secured by means of self-tapping screws, self-drilling rivets or rivets inserted by means of an explosive charge or pins inserted pneumatically, when placed from inside and passing at right angles through the floor and the metallic cross-pieces underneath, on condition, except in the case of self-tapping screws, that some of their ends be flush with the level of the outside part of the cross-piece or be welded on to it.
- (b) The competent authority shall determine what joining devices, and how many of them, must fulfil the requirements of subparagraph (a) of this Note; they shall do so by making sure that the constituent parts so assembled cannot be displaced without leaving visible traces. The choice and placing of other joining devices are not subject to any restriction.
- (c) Joining devices which can be removed and replaced from one side without leaving visible traces, i.e. without requiring handling from both sides of the constituent parts to be assembled, shall not be allowed under subparagraph (a) of this Note. Examples of such devices are expansion rivets, blind rivets and the like. However, blind rivets can be used on condition that a sufficient number of other joining devices as described in Annex 6, Explanatory Note 4.2.1.(a)-1 (a) to the Convention are used to assemble constituent parts.

- (d) The assembly methods described above shall apply to special containers, for example to insulated containers, refrigerated containers and tank containers in so far as they are not incompatible with the technical requirements which such containers must fulfil having regard to their use. Where, due to technical reasons, it is not practicable to secure parts in the manner described in sub-paragraph (a) of this Note, the constituent parts may be joined by means of the devices mentioned in subparagraph (c) of this Note provided that the joining devices used on the inner face of the wall cannot be tampered with from the outside.

Subparagraph 1.(b) - Doors and other closing systems

4.2.1.(b)-1

- (a) The device on which Customs seals can be fixed must :
- (i) be secured by welding, or by not less than two joining devices conforming to subparagraph (a) of Explanatory Note 4.2.1.(a)-1; or
  - (ii) be so designed that when the container has been closed and sealed the device cannot be removed without leaving visible traces
- It must also:
- (iii) incorporate holes of not less than 11 mm in diameter or slots of at least 11 mm in length by 3 mm in width; and
  - (iv) afford equal security whatever type of seal is used.
- (b) Butt hinges, strap hinges, hinge-pins and other devices for hanging doors and the like must be secured in conformity with the requirements of subparagraphs (a)(i) and (ii) of this Note. Moreover, the various components of such devices (e.g. hinge plates, pins or swivels), provided that they are necessary to guarantee Customs security of the container (see sketch No. 7 appended to this Annex), shall be so fitted that they cannot be removed or dismantled when the container is closed and sealed without leaving obvious traces. However, where such a device is not accessible from outside, it will suffice if, when the door or the like has been closed and sealed, it cannot be detached from the device without leaving visible traces. Where a door or closure-device has more than two hinges, only those two hinges nearest to the extremities of the door need be fixed in conformity with the requirements of subparagraphs (a)(i) and (ii) above.

(c) Exceptionally, in the case of insulated containers, the Customs sealing device, the hinges and any fittings the removal of which would give access to the interior of the container or to spaces in which goods could be concealed, may be fixed to the doors of such containers by means of the following systems :

(i) Set bolts or set screws which are inserted from the outside but which do not otherwise meet the requirements of Explanatory Note 4.2.1.(a)-1, sub-paragraph (a) above, on condition that :

the tails of the set bolts or set screws are fixed into a tapping plate or similar device fitted behind the outer layer or layers of the door structure; and

the heads of the appropriate number of set bolts or set screws are so welded to the Customs sealing device, hinges, etc., that they are completely deformed and that the set bolts or set screws cannot be removed without leaving visible signs of tampering (see sketch No. 4 appended to this Annex).

(ii) A fastening device which is inserted from the inside of the insulated door construction on condition that :

the fastening pin and securing collar of the device are assembled by pneumatic or hydraulic tooling and fixed behind a plate or similar device fitted between the outer layer of the door structure and the insulation;

the head of the fastening pin is not accessible from the inside of the container; and

a sufficient number of securing collars and fastening pins are welded together and the devices cannot be removed without leaving visible signs of tampering (see sketch No. 8 appended to this Annex).

The term "insulated container" is to be taken to include refrigerated and isothermic containers.

(d) Containers comprising a large number of such closures as valves, stopcocks, manhole covers, flanges and the like must be designed so as to keep the number of Customs seals to a

minimum. To this end, neighbouring closures must be interconnected by a common device requiring only one Customs seal, or must be provided with a cover meeting the same purpose.

- (e) Containers with opening roofs must be constructed in such a manner as to permit sealing with a minimum number of Customs seals.

Subparagraph 1.(c) – Ventilation apertures

4.2.1.(c)-1

- (a) Their greatest dimension must, in principle, not exceed 400mm.
- (b) Apertures permitting direct access to the container must be obstructed:
  - (i) by means of wire gauze or perforated metal screens (maximum dimension of holes 3 mm in both cases) and protected by welded metal lattice-work (maximum dimension of holes: 10mm); or
  - (ii) by means of a single perforated metal screen of sufficient strength (maximum dimension of holes: 3mm; thickness of the screen: at least 1mm).
- (c) Apertures not permitting direct access to the container (e.g. because of elbow or baffle-plate systems) must be provide with devices referred to in subparagraph (b), in which, however, the dimensions of the holes may be as much as 10 mm (for the wire gauze or metal screen) and 20 mm (for the metal lattice-work).
- (d) Where openings are made in sheets, the devices referred to in subparagraph (b) of this Note must in principle be prescribed. However, blocking devices in the form of a perforated metal screen fitted outside, and wire or other gauze fitted inside, will be allowed.
- (e) Identical non-metal devices may be allowed provided that the holes are of the requisite dimensions and the material used is strong enough to prevent the holes from being substantially enlarged without visible damage. In addition, it must be impossible to replace the ventilation device by working from one side of the sheet only.



(f) The ventilation aperture may be provided with a protective device. This shall be secured to the sheet in such a way as to permit Customs inspection of the aperture. This protective device shall be secured to the sheet at a distance of less than 5cm from the screen of the ventilation aperture.

Subparagraph 1.(c) – Drainage apertures

4.2.1.(c)-2

(a) their greatest dimension must, in principle, not exceed 35mm.

(b) Apertures permitting direct access to the goods must be provided with the devices described in subparagraph (b) of Explanatory Note 4.2.1.(c)-1 for ventilation apertures.

(c) When drainage apertures do not permit direct access to the goods, the device referred to in subparagraph (b) of this Note will not be prescribed, on condition that the apertures are provided with a reliable baffle system readily accessible from inside the container.

4.4 Article 4

Paragraph 3 – Sheets made up of several pieces

4.4.3-1

(a) The several pieces constituting one sheet may be made of different materials conforming to the provisions of Annex 4, Article 4, paragraph 2.

(b) Any arrangement of the pieces which adequately guarantees security will be allowed in making up the sheet, on condition that the pieces are assembled in conformity with the requirements of annex 4, Article 4.

Subparagraph 6.(a)

4.4.6.(a)-1

Examples of a construction system for affixing container sheets and of a system of affixing sheets around containers' corner-castings, acceptable from a Customs point of view, are given in sketches No. 1, No. 2 and No. 3 appended to this Annex.

Subparagraph 6.(a)(i) - Sheeted containers with sliding rings

4.4.6.(a)-2

Metal securing rings on metal bars fixed to the containers are acceptable for the purposes of this paragraph (see sketch No. 5 appended to this Annex) provided that :

- (a) the bars are affixed to the container at maximum spacings of 60 cm and in such a manner that they cannot be removed and replaced without leaving obvious traces;
- (b) the rings are made with a double hoop or equipped with a central bar and made in one piece without the use of welding; and
- (c) the sheet is fixed to the container in strict compliance with the conditions set forth in Annex 4, Article 1 (a) of this Convention.

Subparagraph 6.(a)(i) - Sheeted containers with swivel rings

4.4.6.(a)-3

Metal swivel rings, each of which rotates in a metal bracket fixed to the container are acceptable for the purpose of this paragraph (see sketch No. 6 appended to this Annex) provided that :

- (a) each bracket is affixed to the container in such a manner that it cannot be removed and replaced without leaving obvious traces; and
- (b) the spring under each bracket is completely enclosed by a bell-shaped metal cover.

Subparagraph 6.(b) - Permanently-secured sheets

4.4.6.(b)-1

Where one or more edges of the sheet are permanently attached to the body of the container, the sheet shall be held in place by one or more strips of metal or other suitable material secured to the body of the container by joining devices meeting the requirements of sub-paragraph (a) of Note 4.2.1.(a)-1 of this Annex.

Paragraph 8 - Spaces between the rings and between the eyelets

4.4.8.-1

Spaces exceeding 200 mm but not exceeding 300 mm are acceptable over the uprights if the rings are recessed in the side boards and the eyelets are oval and so small that they can just pass over the rings.

Paragraph 9 - Textile-cored fastening ropes

4.4.9.-1

For the purposes of this paragraph, ropes comprising a textile core surrounded by at least four strands consisting solely of steel

wire and completely covering the core will be allowed on condition that the ropes (without taking into account the transparent plastic sheath, if any) are not less than 3 mm in diameter.

Subparagraph 11.(a)(i) - Sheet-tensioning flaps

4.4.11.(a)(i)

The sheets of many containers are provided on the outside with a horizontal flap pierced by eyelets running along the length of the side of the container. Such flaps, known as tensioning flaps, are used to tauten the sheet by means of tensioning cords or similar devices. Such flaps have been used to conceal horizontal slits made in the sheets giving improper access to the goods carried in the container. It is therefore recommended that the use of flaps of this type should not be allowed. The following devices may be used instead :

- (a) tensioning flaps of similar design fixed on the inside of the sheet; or
- (b) small individual flaps each pierced by one eyelet secured to the outside surface of the sheet and spaced at such distances as will permit an adequate tensioning of the sheet.

Alternatively, it may be possible in certain cases to avoid the use of tensioning flaps on sheets.

Subparagraph 11.(a)(iii) - Sheets thongs

4.4.11.(a)(iii)-1

The following materials are regarded as suitable for making thongs :

- (a) leather;
- (b) non-tensile textile materials including plastic-proofed or rubberized cloth, provided that such materials cannot after severance be welded or reconstituted without leaving obvious traces. Furthermore, the plastic material used to cover thongs shall be transparent and smooth surfaced.

4.4.11.(a)(iii)-2

The device shown in sketch No. 3 appended to this Annex meets the requirements of the last part of subparagraph 11.(a) of Article 4 of Annex 4. It also meets the requirements of Annex 4, Article 4, paragraph 6, subparagraph (a).

5. Annex 5

## 5.1 Paragraph 1 - Approval of a combination of sheeted containers

### 5.1.-1

If two sheeted containers, approved for transport under Customs seal have been joined together in such a way that they form one container, covered by a single sheet and fulfilling the conditions for transport under Customs seal, a separate certificate of approval, or approval plate, shall not be required for the combination.

Annex 6 – Sketch No.1

CONSTRUCTION DEVICE FOR AFFIXING CONTAINER SHEETS

The device illustrated below meets the requirements of Annex 4, Article 4, Subparagraph 6(a).

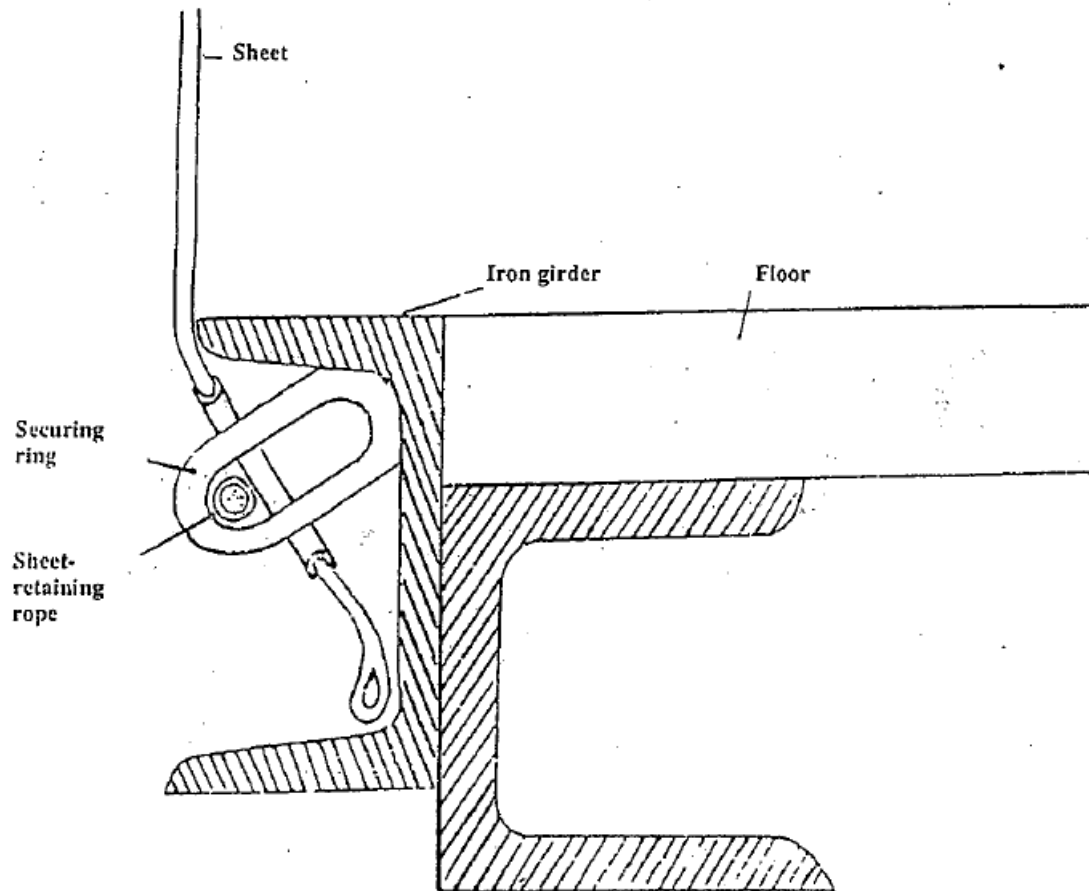

Annex 6 - Sketch No. 2

DEVICE FOR AFFIXING SHEETS AROUND CONTAINERS' CORNER-CASTINGS

The device illustrated below meets the requirements of Annex 4, Article 4, paragraph 6(a).

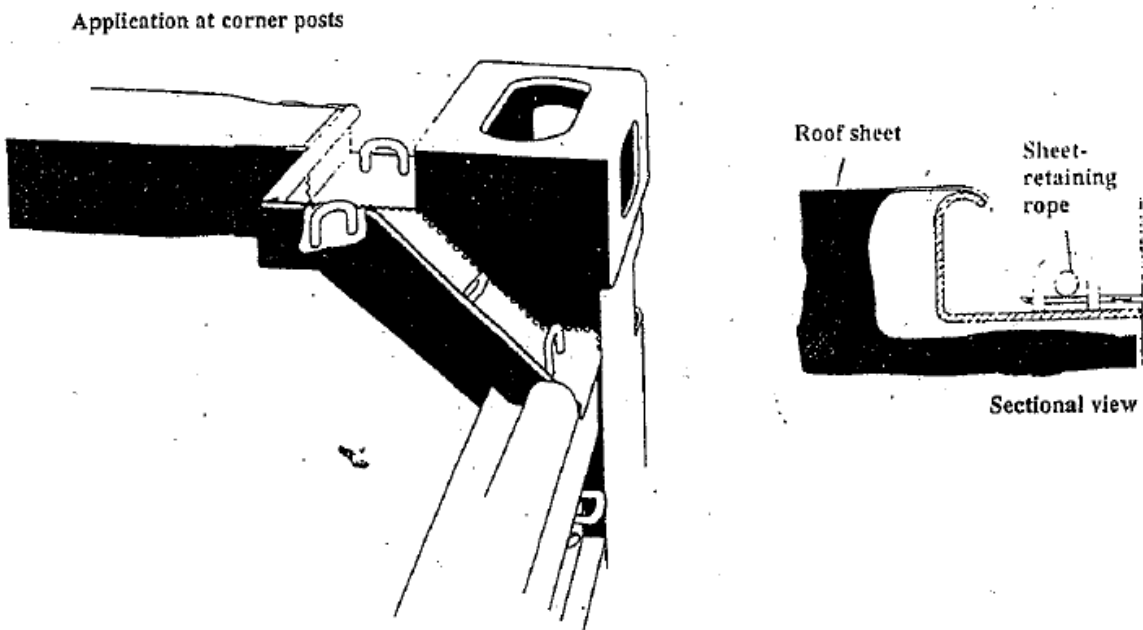

Annex 6 – Sketch No. 3

FURTHER EXAMPLE OF A METHOD OF AFFIXING CONTAINER SHEETS

The device illustrated below meets the requirements of the last part of Subparagraph 11.(a) of Article 4 of Annex 4. It also meets the requirements of Annex 4, Article 4, paragraph 6.

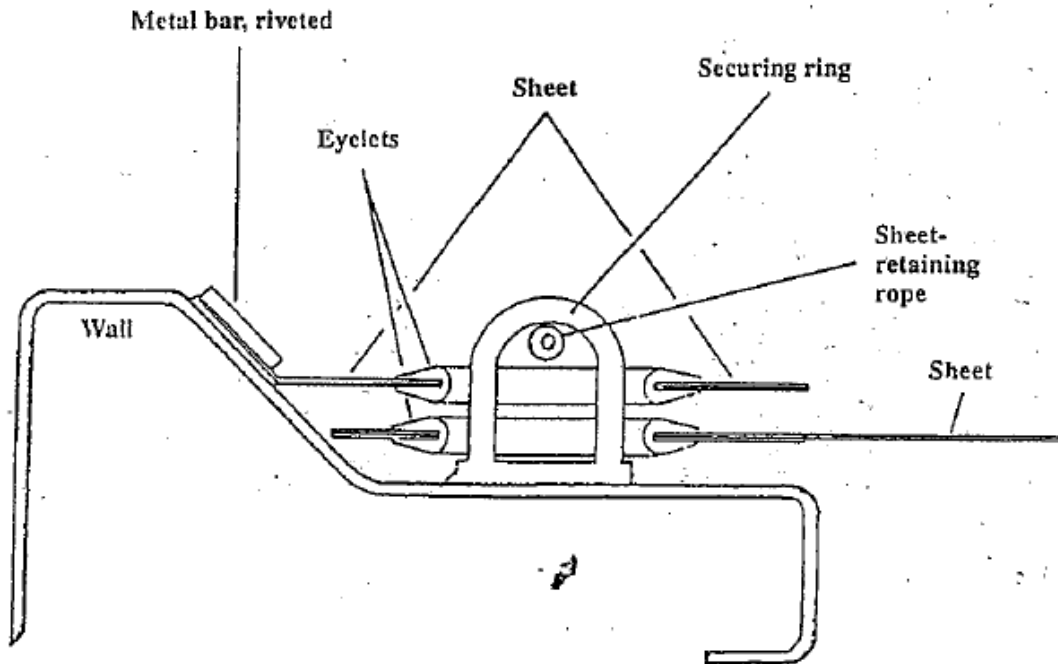

Annex 6 - Sketch No. 4

EXAMPLE OF HINGE AND CUSTOMS SEALING DEVICE  
ON DOORS OF INSULATED CONTAINERS

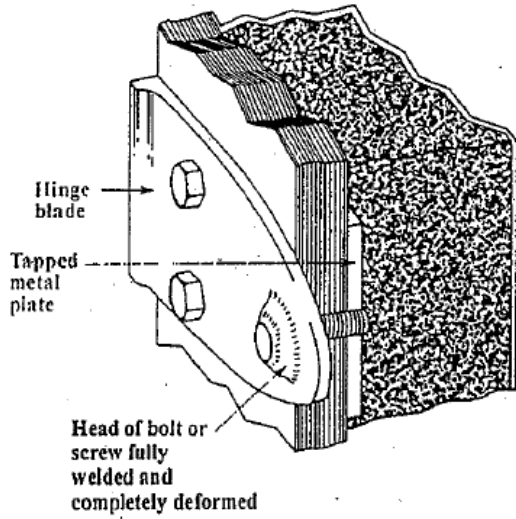

Hinge

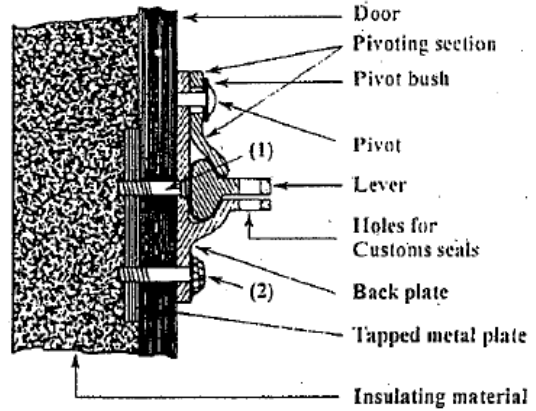

(1) Set-screw head completely deformed by welding. Not accessible when door sealed

(2) Head of set-bolt or set-screw completely deformed by welding

Customs sealing device



Annex 6 - Sketch No. 5

SHEETED CONTAINERS WITH SLIDING RINGS

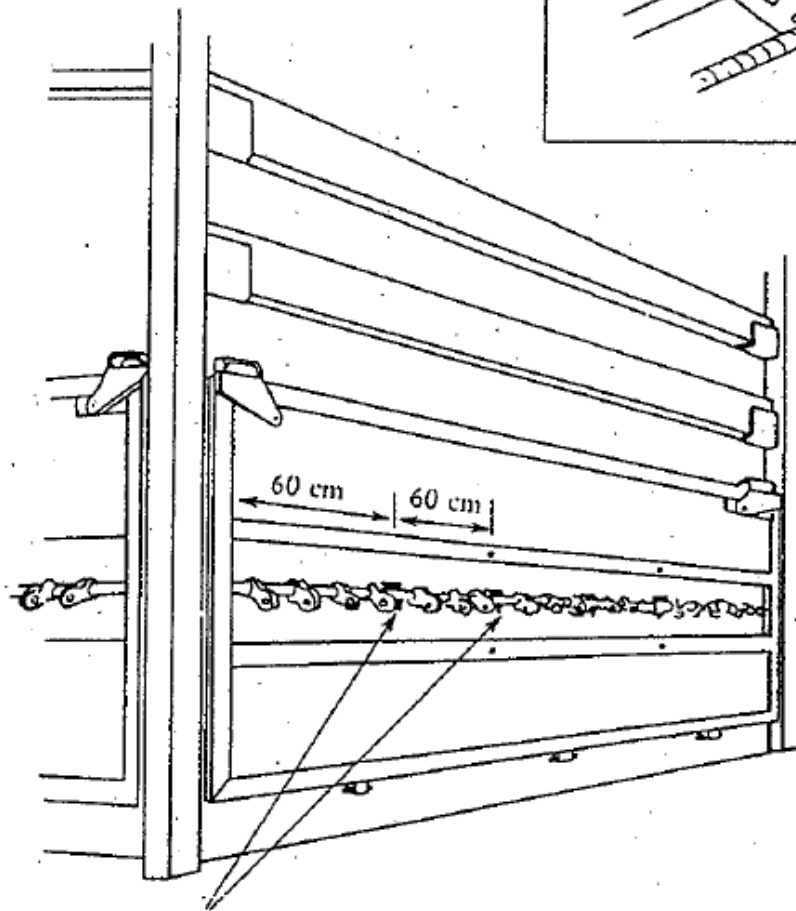
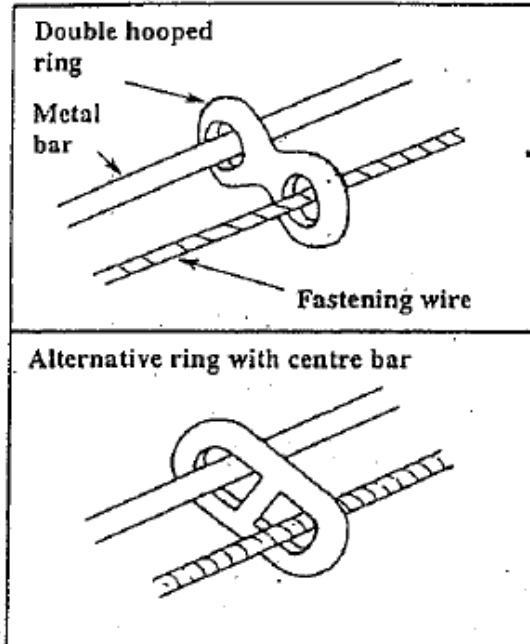

Bar attachment points

Annex 6 - Sketch No. 6

EXAMPLE OF A SWIVEL RING ("D" RING)

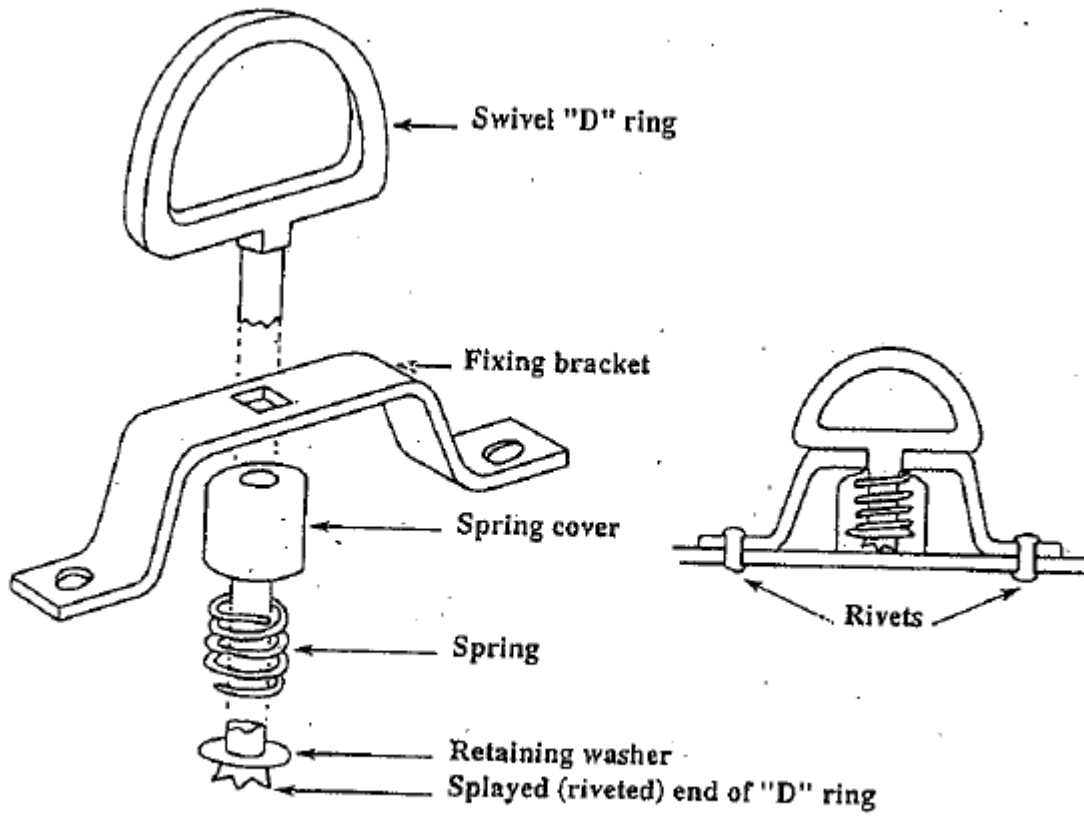

Annex 6 - Sketch No. 7

EXAMPLE OF A HINGE NOT REQUIRING SPECIAL PROTECTION FOR THE HINGE-PIN

The hinge illustrated below complies with the requirements of Explanatory Note 2.2.1(b), paragraph (b), second sentence. The design of the strap and the hinge-plate make any special protection of the pin unnecessary, since the shoulders of the strap extend behind the edges of the hinge-plate. These shoulders therefore prevent the Customs-sealed door from being opened at the hinged side without leaving obvious traces, even if the unprotected pin has been removed.

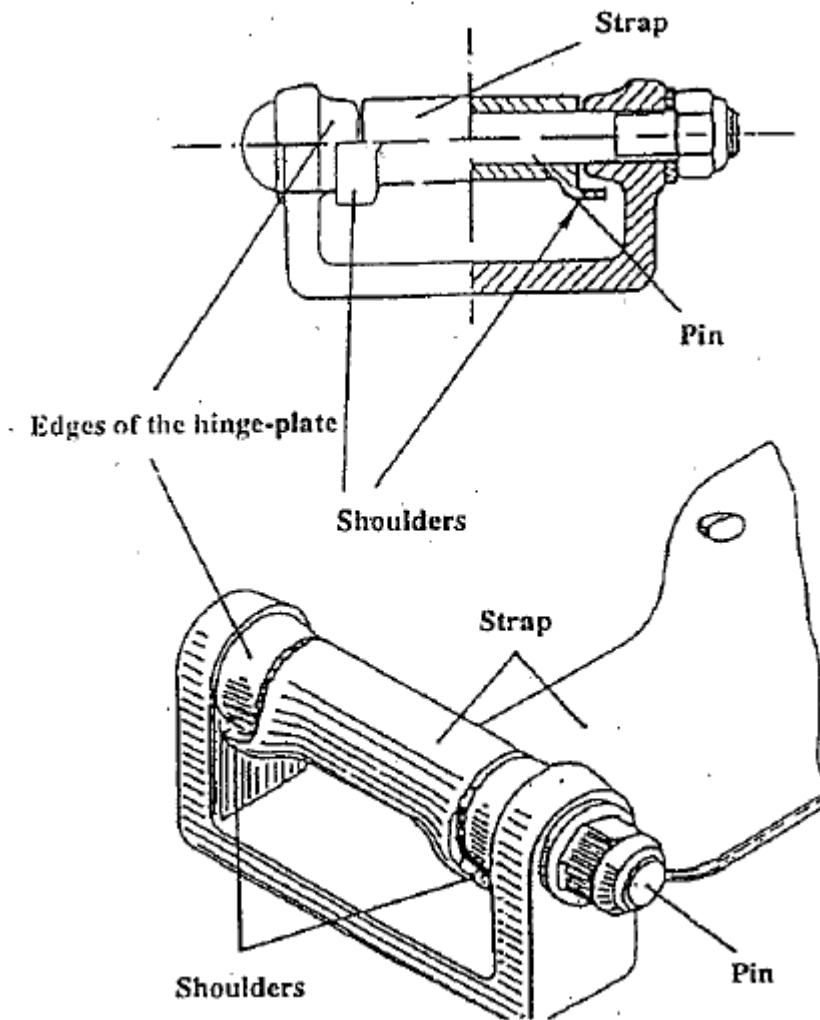

Annex 6 - Sketch No. 8

EXAMPLE OF A FASTENING DEVICE INSERTED FROM THE INSIDE OF INSULATED DOOR CONSTRUCTION

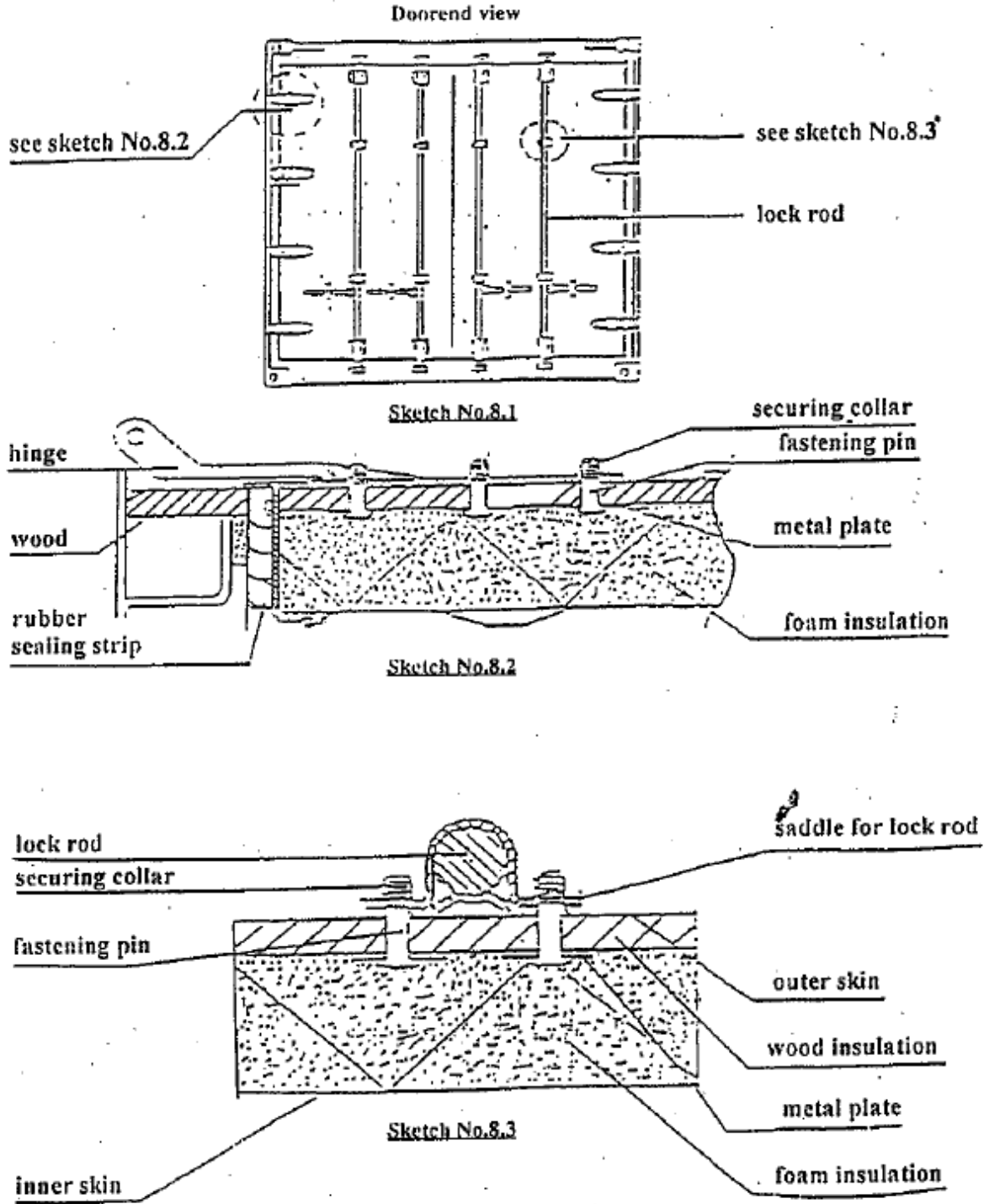

## ANNEX 7

### Composition and rules of procedure of the Administrative Committee

#### Article 1

- 1 The Contracting Parties shall be members of the Administrative Committee.
- 2 The Committee may decide that the competent administrations of States referred to in Article 18 of the present Convention which are not Contracting Parties or representatives of international organizations may, for questions which interest them, attend the sessions of the Committee as observers.

#### Article 2

The Customs Co-operation Council shall provide the Committee with secretariat services.

#### Article 3

The Committee shall, at its first session each year, elect a Chairman and a Vice-Chairman.

#### Article 4

The competent administrations of the Contracting Parties shall communicate to the Customs Co-operation Council proposed amendments to the present Convention and the reasons therefor, together with any requests for the inclusion of items on the Agenda of the sessions of the Committee. The Customs Co-operation Council shall bring them to the attention of the competent administrations of the Contracting Parties and of the States referred to in Article 18 of the present Convention which are not Contracting Parties.

#### Article 5

- 1 The Customs Co-operation Council shall convene the Committee at a time fixed by the Committee but not less frequently than once every two years and also at the request of the competent administrations of at least five Contracting Parties. It shall circulate the draft Agenda to the competent administrations of the Contracting Parties and of the States referred to in Article 18 of the present Convention which are not Contracting Parties at least six weeks before the Committee meets.
- 2 On the decisions of the Committee, taken by virtue of the provisions of Article 1, paragraph 2, of these rules, the Customs Co-operation Council shall invite the

competent administrations of the States referred to in Article 18 of the present Convention which are not Contracting Parties and the international organizations concerned to be represented by observers at the sessions of the Committee.

#### Article 6

Proposals shall be put to the vote. Each Contracting Party represented at the meeting shall have one vote. Proposals other than amendments to the present Convention shall be adopted by the Committee by a majority of those present and voting. Amendments to the present Convention, and decisions referred to in Article 21, paragraph 5, and Article 22, paragraph 6, of the present Convention regarding entry into force of amendments, shall be adopted by a two-thirds majority of those present and voting.

#### Article 7

Before the closure of its session, the Committee shall adopt a report.

#### Article 8

In the absence of relevant provisions in this Annex, the Rules of Procedure of the Customs Co-operation Council shall be applicable unless the Committee decides otherwise.

## PROTOCOL OF SIGNATURE

At the time of signing the present Convention of this day's date the undersigned, being duly authorized by their Governments, make the following declarations:

- 1           The addition, for the purpose of calculating import duties and taxes levied on importation, of the weight or value of containers granted temporary admission to the weight or value of the goods they contain, conflicts with the principle of the temporary admission of containers. The addition of a legally-determined tare-weight factor to the weight of goods conveyed in containers is permissible if it is made because of the absence of packaging or because of the nature of the packaging, and not because the goods are conveyed by container.
  
  - 2           The terms of the present Convention shall not preclude the application of national provisions or of international agreements, not of a Customs nature, regulating the use of containers.
  
  - 3           The one-cubic-metre limitation of the internal volume, provided for in Article 1 of the present Convention, does not imply the application of more restrictive regulations to containers of a smaller volume, and the Contracting Parties shall endeavour to apply a temporary admission procedure to the latter similar to that which they apply to containers defined in the present Convention.
  
  - 4           As far as the procedures for the temporary admission of containers provided for in Articles 6, 7 and 8 of the present Convention are concerned, the Contracting Parties recognize that the abolition of all Customs documents and guarantees would enable them to achieve one of the main purposes of the present Convention, and they will make every effort to attain this.
-