

THALES

www.thalesgroup.com/microelectronics

CONSULT US TO GET
YOUR OWN
CUSTOM MODULE!

FUNCTIONAL DESCRIPTION

5kW Hi-density complete power motor-driving module

Thales Microelectronics

5kW Hi-density Power module



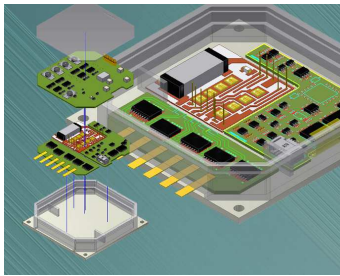

5kW Hi-density Power module

TECHNOLOGIES

- 1200V Silicon Carbide Mosfet
- Magneto-resistive current sensors
- Hi-thermal conductive substrate (Si_3N_4)
- Ag Sinter die attach
- Al SiC baseplate

FEATURES & ASSETS

- Input voltage 540Vdc
- Output current 10A per phase
- Dimensions: 100mm x 100mm x 20mm
- Power density 25kW/L

APPLICATIONS

- Hi-density motor-driving for actuators :
 - primary/secondary flight controls
 - Thrust reversers
 - Landing gears
 - Hybrid power trained engines

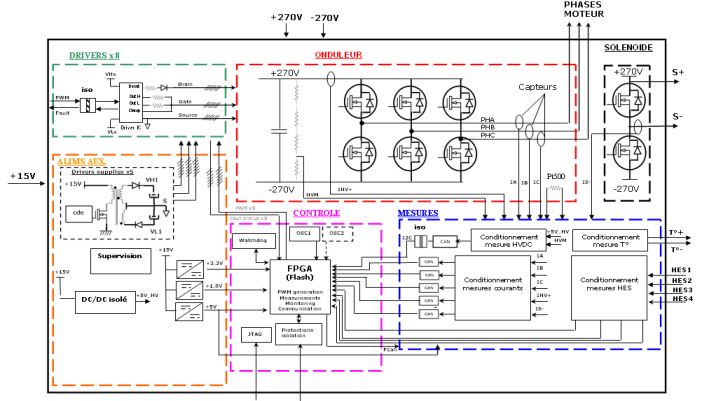

PHYSICAL DESCRIPTION

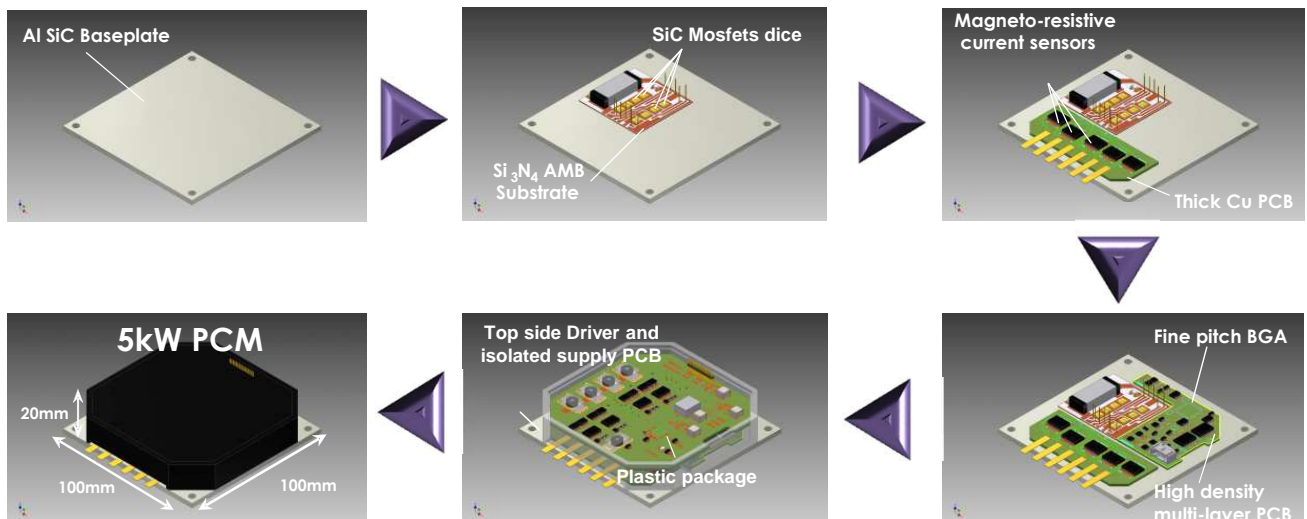

THALES

Thales Microelectronics S.A.S - Z.A. Piquet - 35370 ETRELLES - France.
 contact.tmi@fr.thalesgroup.com / Tel. +33 (0)2 23 55 40 00 - Fax. +33 (0)2 23 55 44 73