

GENTENAIRE BENCH - SMALL ELEMENTS

Overview



Colors*

Acid wash

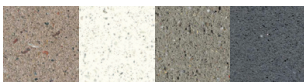

A22 A30 A33 A38

Weatherstone

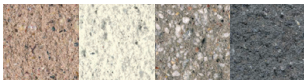

W22 W30 W33 W38

* Additional colors available on WausauTile.com

Handling

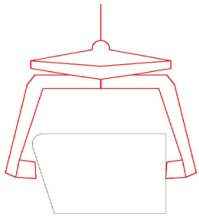

Accessories for this product



- Recycled plastic lumber seating on stainless steel structure
- Skatestoppers
- Armrests

Designer



Urbastyle Design Team

Elements	Length inch	Width inch	Height inch	Weight lbs/p
ZB.CE.01	48	24	16	1,500
ZB.CE.02	48	24	16	1,377
ZB.CE.03	48	24	16	1,377
ZB.CE.04	48	24	16	1,416
ZB.CE.05	48	24	16	1,295
ZB.CE.06	48	24	16	1,425
ZB.CE.07	36	24	16	1,038
ZB.CE.08	48	24	16	1,140
ZB.CE.09	48	24	16	1,140
ZB.CE.10	48	24	16	1,113
ZB.CE.11	48	24	16	1,113

! Special custom manufacturing. Order and delivery time on request

↳ Recycled Plastic Lumber seating only available on straight elements

Product description

Characteristics

- Prefabricated concrete element
- Finish:
 - > Acid wash : a light acid etch finish with an even and flat texture across the entire surface
 - > Weatherstone : a sandblast finish exposing rock and giving a subtle texture and weathered look
- Hidden anchoring
- Optional top mounted recycled plastic lumber seating available

Delivery information

- Delivery only on pallets

Project study information

- Specific dimensions in custom manufacturing (only on order): on demand

Shipping fees

- On demand



CENTENAIRE BENCH - SMALL ELEMENTS

ZB.CE.01

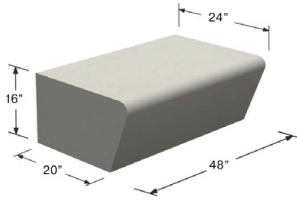

Details - ZB.CE.01

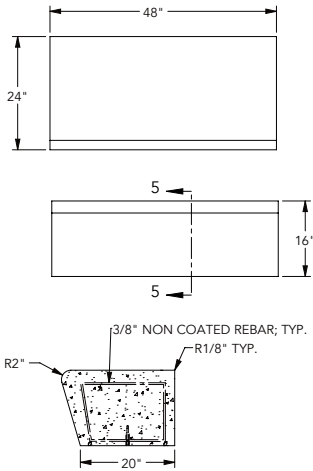

ZB.CE.02

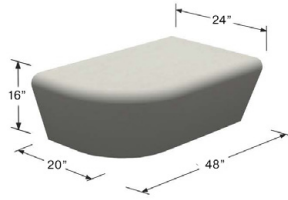

Details - ZB.CE.02

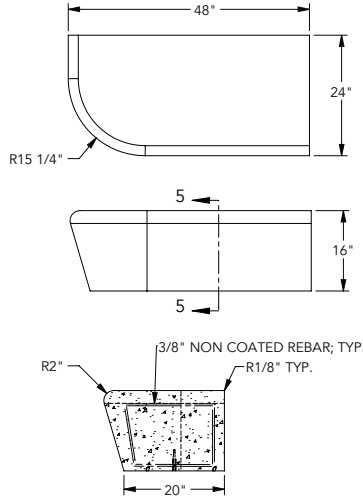

ZB.CE.03

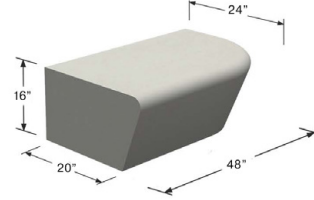

Details - ZB.CE.03

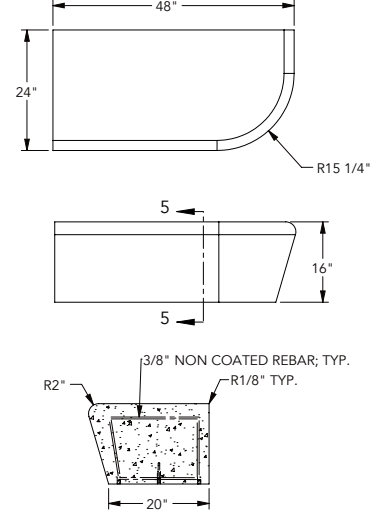

ZB.CE.04

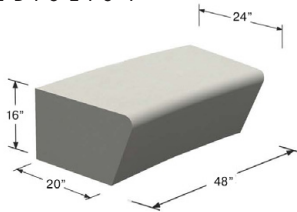

Details - ZB.CE.04

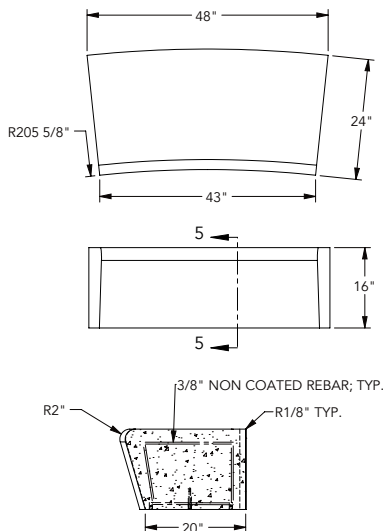

ZB.CE.05

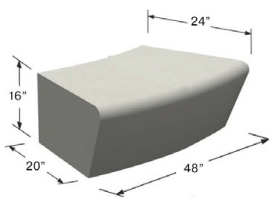

Details - ZB.CE.05

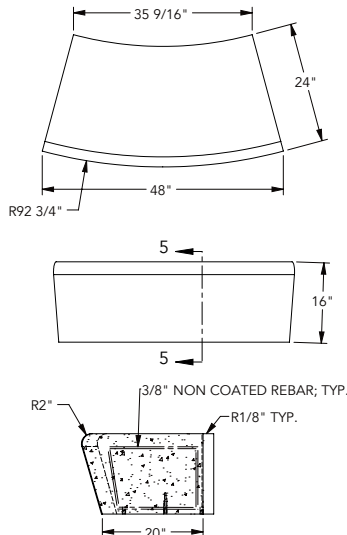

ZB.CE.06

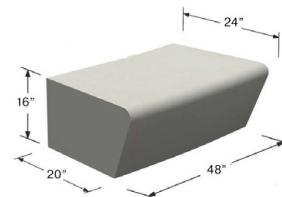

Details - ZB.CE.06

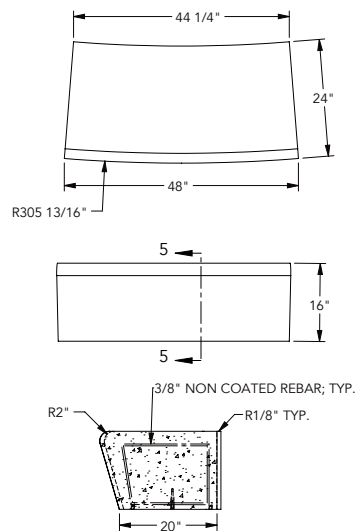

CENTENAIRE BENCH - SMALL ELEMENTS

ZB.CE.07

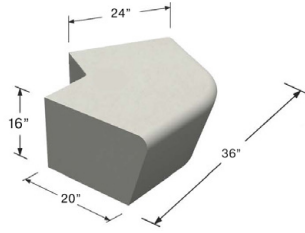

Details - ZB.CE.07

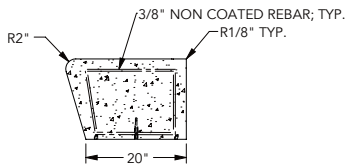
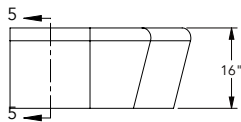
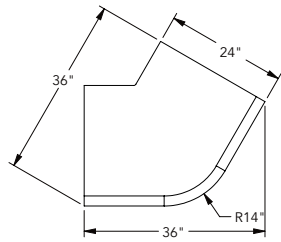

ZB.CE.08

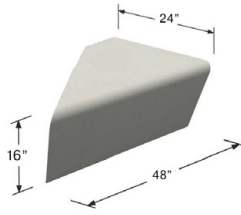

Details - ZB.CE.08

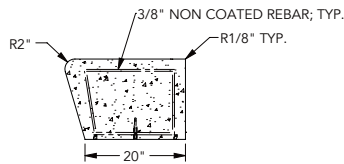
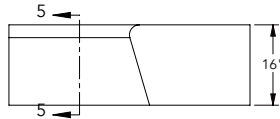
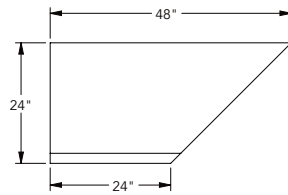

ZB.CE.09

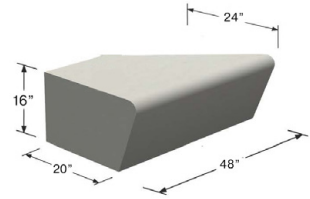

Details - ZB.CE.09

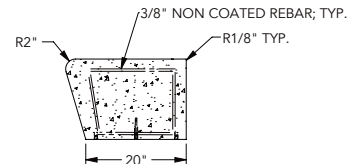
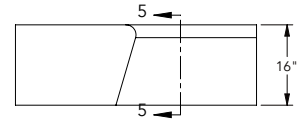
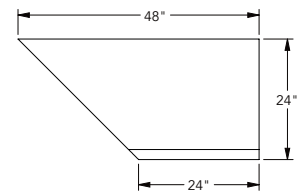

ZB.CE.10

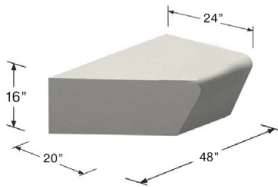

Details - ZB.CE.10

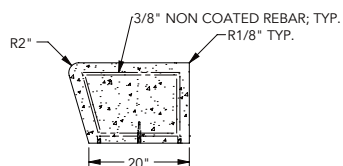
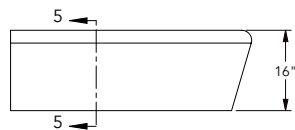
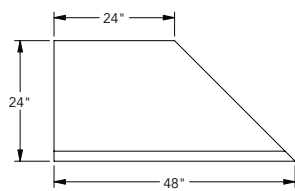

ZB.CE.11

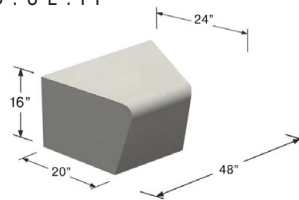

Details - ZB.CE.11

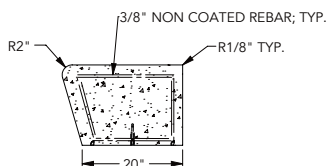
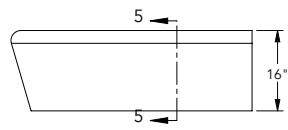
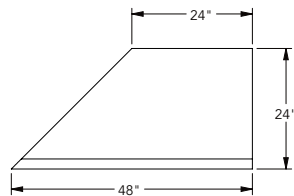

CENTENAIRE BENCH - LARGE ELEMENTS

Overview

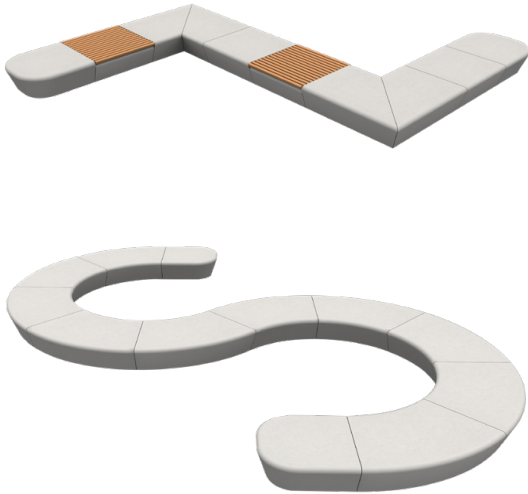

Colors*

Acid wash

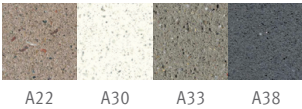

Weatherstone

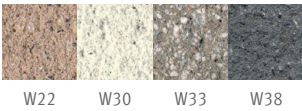

* Additional colors available on WausauTile.com

Handling

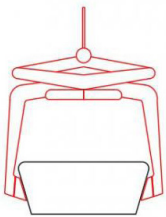

Designer



Urbastyle Design Team

Elements	Length inch	Width inch	Height inch	Weight lbs/p
ZB.CE.12	48	48	16	2,971
ZB.CE.13	48	48	16	2,755
ZB.CE.14	42	48	16	2,344
ZB.CE.15	42	48	16	2,343
ZB.CE.16	42	48	16	2,343
ZB.CE.17	60	48	16	2,842
ZB.CE.18	59 11/16	48	16	3,380
ZB.CE.19	60	48	16	2,228
ZB.CE.20	60	48	16	2,228

! Special custom manufacturing. Order and delivery time on request
 † Recycled Plastic Lumber seating only available on straight elements

Product description

Characteristics

- Prefabricated concrete element
- Finish:
 - > Acid wash : a light acid etch finish with an even and flat texture across the entire surface
 - > Weatherstone : a sandblast finish exposing rock and giving a subtle texture and weathered look
- Hidden anchoring
- Optional top mounted recycled plastic lumber seating available

Delivery information

- Delivery only on pallets

Project study information

- Specific dimensions in custom manufacturing (only on order): on demand

Shipping fees

- On demand

Accessories for this product



- Recycled plastic lumber seating on stainless steel structure
- Skatestoppers
- Armrests



CENTENAIRE BENCH - LARGE ELEMENTS

ZB.CE.12

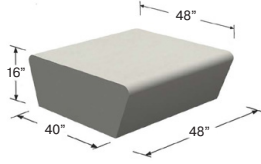

Details - ZB.CE.12

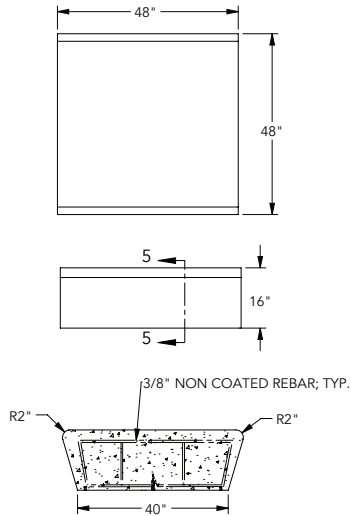

ZB.CE.13

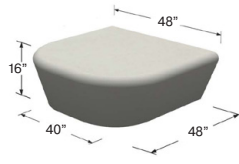

Details - ZB.CE.13

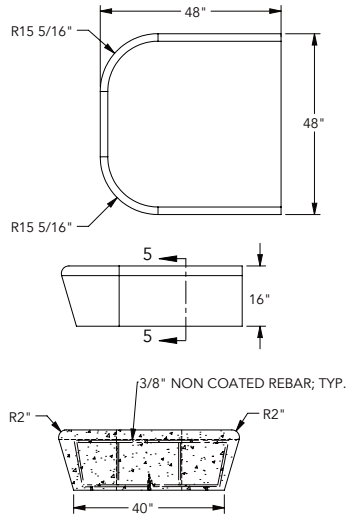

ZB.CE.14

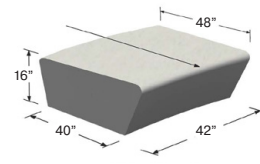

Details - ZB.CE.14

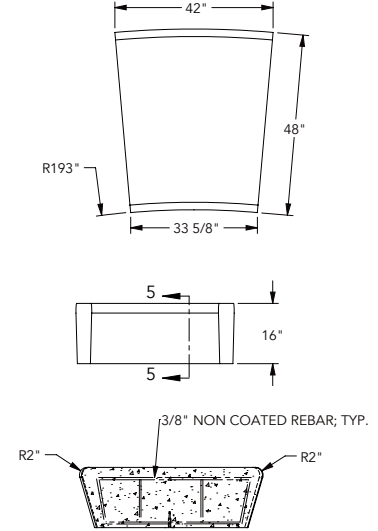

ZB.CE.15

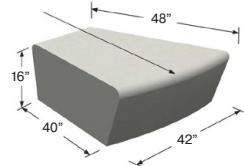

Details - ZB.CE.15

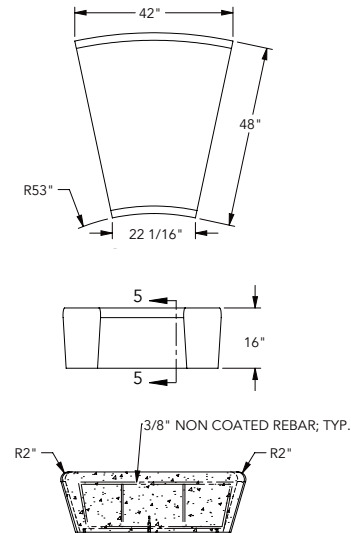

ZB.CE.16

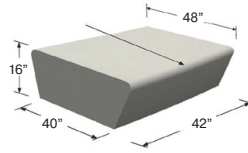

Details - ZB.CE.16

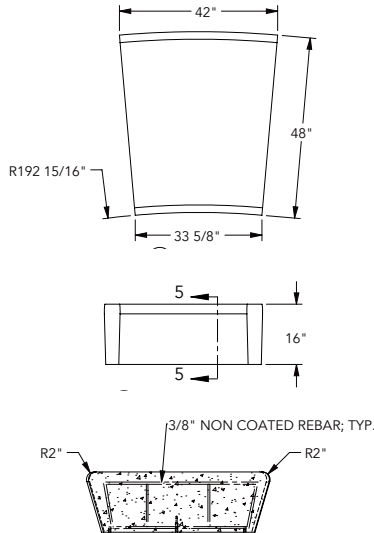

ZB.CE.17

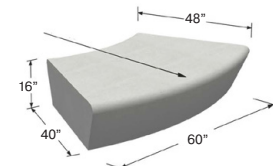

Details - ZB.CE.17

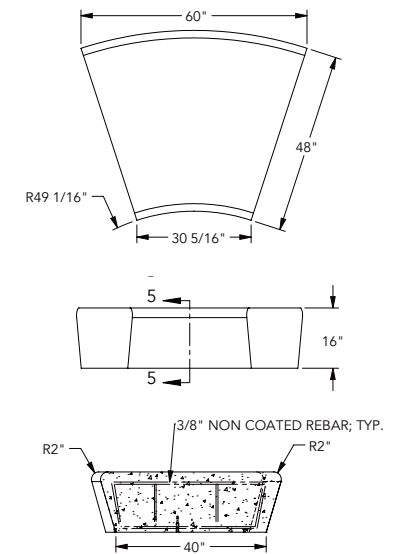

CENTENAIRE BENCH LARGE ELEMENTS

ZB.C.F.18

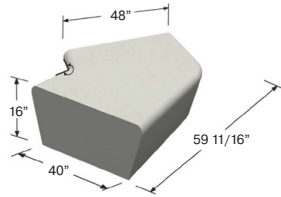

Details - ZB.C.E.18

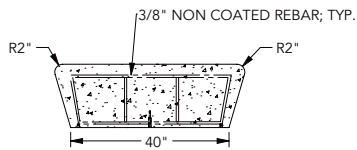
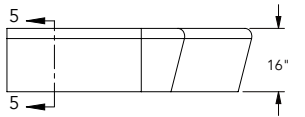
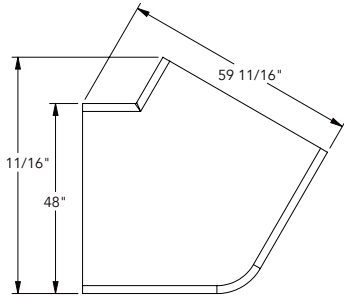

ZB.C.E.19

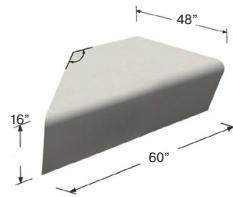

Details - ZB.C.E.19

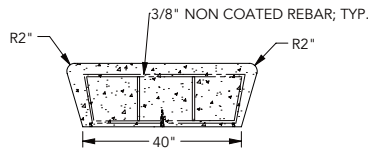
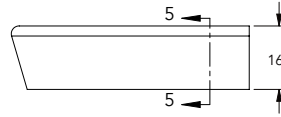
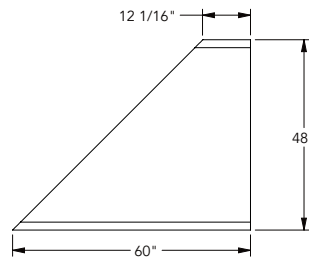

ZB.C.E.20

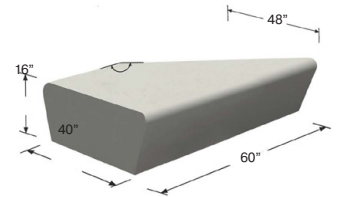

Details - ZB.C.E.20

