

**NYC Department of Education
Building Condition Assessment Survey 2023-2024**

Architectural Inspection

X167

Asset: P.S. 214 - BRONX, 1970 WEST FARMS ROAD, BRONX, NY, 10460

Inspection Id	Inspection Type	Time In	Last Edited
4295	ARCHITECTURAL - ASSOCIATE	2024-03-27 09:20AM	2024-05-01 11:39AM
4304	ARCHITECTURAL - SENIOR	2024-03-27 07:57AM	2024-06-16 06:28PM

Asset Data

Question	Answer
Was the Building Fully Accessible for Inspection?	No
Inspection Inaccessible Comment	Girls and Boys Shower Rooms (sealed w/ storage)
Principal(s) Information	
Principal Name	Melissa DeJesus
Principal Organization	P.S. 214 - Bronx
Meeting with Principal?	Yes
Principal Feedback	The principal provided the following comment: The ventilation in the building, particularly on the 2nd floor/5th grade wing, is malfunctioning with no output and is unhealthy to some of our students with respiratory issues. This must be addressed and resolved.
Principal Name	Michael Abbey
Principal Organization	I.S. 383 - Bronx
Meeting with Principal?	No
Principal Feedback	No Feedback from Principal
Custodian	Manuel Diaz
Was the Custodian Present?	Yes
Fireman	Edwin Cosme
Was the Fireman Present?	No
Building Square Footage	173,000
Comments on the Area (for Athletic Field, Playing Surfaces, Leased Spaces)	None
Comments on the Stories (Floors) plus Basements	3+B+PH
Comments on the Year Built	1973
Student Population	1246
Staff Population	210
Comments on the Number of Classrooms	72
Weather	Fair
Facade Photo	



West Farms Road - Southeast View

**NYC Department of Education
Building Condition Assessment Survey 2023-2024**

Architectural Inspection

X167

Main Entrance Photo



Facade A - West Farms Avenue

Roof Photo

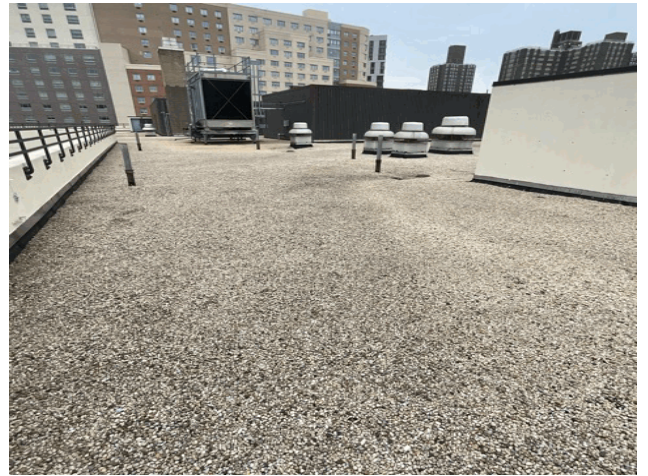

Roof 1 - West View

Do Stormwater Management/Green Infrastructure systems exist?

Yes

Type

Tree Pit/Rain Garden/Infiltration Basin

Have any Systems/Major Building Components been upgraded?

Systems: Complete exterior repairs including masonry repointing, concrete patching and selective flashing/roofing repairs at Exterior Walls, Parapets and Bulkheads. New exterior paint.

Have there been any New Building Additions?

Years: 2023

Tandem

No New Construction

Leased Space?

No Tandem

No

Priority Condition

Exist Last Year?	Priority Category	Condition Description	Component Affected	Location Description	Person(s) Notified	Person(s) Title	Photo Image
Yes	Damaged/Deteriorated Railings	Broken railing has sharp edge projecting.	Railings	Exit 10	Manuel Diaz	Custodian	

Structural Engineer Required

Structural Condition Type	Condition Description	Component Affected	Location Description	Person(s) Notified	Person(s) Title	Photo Image
No condition recorded						

**NYC Department of Education
Building Condition Assessment Survey 2023-2024**

Architectural Inspection

X167

Programmatic Accessibility

Programmatic Accessibility Status Question	Response
Is the Primary or secondary entrance on an accessible route?	Yes
Is the building a multi-story building?	Yes
Are All floors of the building accessible through compliant means?	Yes
Accessible classrooms exists on each floor?	Yes
Boys and Girls or Unisex accessible toilets exist on at least every other floor?	Yes
If the following spaces exist, are they ALL accessible? Art Room, Auditorium, Cafeteria, Computer, Gymnasiums, Library, Multipurpose Room, Science Labs	Yes

Physical Breakdown Structure	Exists	Complies	Required	Deficiency	Assistive Listening System	Fire Alarm Strobe
------------------------------	--------	----------	----------	------------	----------------------------	-------------------

PROGRAMMATIC ACCESSIBILITY

Exterior Routes

Exterior Entrances & Exits		Yes				
Exterior H/C Lifts	No		No			
Exterior Ramps and Railings	No		No			

Interior Routes

Corridor and Lobby H/C Lifts	No		No			
Interior Corridor Doors And Hardware	Yes	Yes				
Interior Corridors & Lobbies		Yes				
Interior Elevators	Yes	Yes				
Interior Lobby Doors And Hardware		Yes				
Interior Ramps	Yes	Yes				

Rooms & Spaces

Art Rooms

Room 257	Yes	Yes				
----------	-----	-----	--	--	--	--

Auditorium

2nd Floor	Yes	Yes		No	Yes	
-----------	-----	-----	--	----	-----	--

Cafeteria

1st Floor - Staff, 1st Floor - Students	Yes	Yes		No	Yes	
--	-----	-----	--	----	-----	--

Classrooms

1st to 3rd Floor	Yes	Yes				
------------------	-----	-----	--	--	--	--

Computer Rooms

	No					
--	----	--	--	--	--	--

Gymnasium

Basement	Yes	Yes		No	Yes	
----------	-----	-----	--	----	-----	--

Library

Room 231	Yes	Yes				
----------	-----	-----	--	--	--	--

Main Office

Rooms 149 (P.S. 214), 354 (I.S. 383) and 154 (DOE Office - District 12)	Yes	Yes				
--	-----	-----	--	--	--	--

Multi-purpose Room

	No					
--	----	--	--	--	--	--

Nurse's Office

Room 146	Yes	Yes				
----------	-----	-----	--	--	--	--

Pool

	No					
--	----	--	--	--	--	--

Science Lab

Rooms 103, 105, 203, 205, 303, 305	Yes	Yes				
---------------------------------------	-----	-----	--	--	--	--

Toilet Rooms (boys)

**NYC Department of Education
Building Condition Assessment Survey 2023-2024**

Architectural Inspection

X167

Physical Breakdown Structure	Exists	Complies	Required	Deficiency	Assistive Listening System	Fire Alarm Strobe
1st and 3rd Floors	Yes	Yes				
Toilet Rooms (girls)						
1st and 3rd Floors	Yes	Yes				
Toilet Rooms (staff)						
1st and 3rd Floors	Yes	Yes				

Building Template

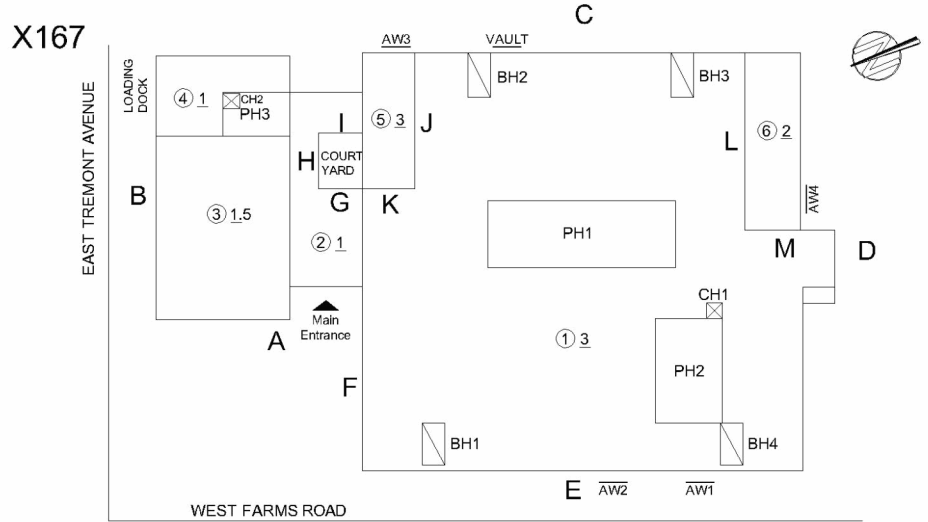

Inspection

Question	Response
Architectural	
EXTERIOR	Inspected
AREAWAY	Inspected
Instance on AW1-AW4	Inspected
Instance Condition	2- Between Good and Fair
Instance Quantity	4
Instance Quantity Uom	EACH
Deficiency	No deficiencies recorded
AWNINGS AND CANOPIES	Inspected
Condition	2- Between Good and Fair
Deficiency	No deficiencies recorded
CHIMNEY	Inspected
Material Type(s)	Masonry
Condition	3- Fair
Deficiency	BRICK:MAJOR / THRU CRACKS
Deficiency Location/Instance	
Deficiency Quantity	50
Quantity Uom	S.F.
Potential Action	REMOVE AND REBUILD
Urgency of Action	PRIORITY 4

**NYC Department of Education
Building Condition Assessment Survey 2023-2024**

Architectural Inspection

X167

Question **Response**

EXTERIOR

CHIMNEY

Purpose of Action
Deficiency Photo 1

LEVEL 2



Chimney CH1

No photo recorded

No violations recorded

Deficiency Photo 2
Violations

COPING

Does not exist

CORNICE

Does not exist

DOORS

Inspected

DOORS AND FRAMES

Inspected

Condition

4- Between Fair and Poor

Deficiency

METAL CLAD:DETERIORATED DOOR AND FRAME - MAJOR DETERIORATION

Deficiency Location/Instance

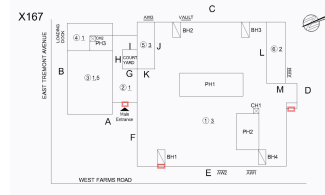

Deficiency Quantity

3

Quantity Uom

EACH

Potential Action

REPLACE

Urgency of Action

PRIORITY 4

Purpose of Action

LEVEL 2

Deficiency Photo 1



Exit 2

No photo recorded

No violations recorded

Deficiency Photo 2

Violations

Deficiency

METAL CLAD:DETERIORATED DOOR AND FRAME - MINOR DETERIORATION

Deficiency Location/Instance

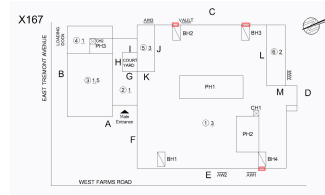

Deficiency Quantity

3

Quantity Uom

EACH

Potential Action

MAINTENANCE



Urgency of Action

PRIORITY 3

**NYC Department of Education
Building Condition Assessment Survey 2023-2024**

Architectural Inspection

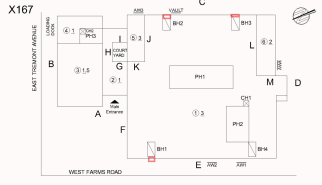
X167

Question	Response
EXTERIOR	
DOORS	
DOORS AND FRAMES	
Purpose of Action	LEVEL 2
Deficiency Photo 1	
Deficiency Photo 2	Exit 4
Violations	No photo recorded No violations recorded
DOOR HARDWARE	Inspected
Condition	3- Fair
Deficiency	No deficiencies recorded
LINTELS	Inspected
Condition	2- Between Good and Fair
Deficiency	No deficiencies recorded
TRANSOM/SIDE LIGHT	Inspected
Condition	4- Between Fair and Poor
Deficiency	METAL:DENTED, MAJOR RUSTING
Deficiency Location/Instance	
Deficiency Quantity	20
Quantity Uom	S.F.
Potential Action	REPLACE
Urgency of Action	PRIORITY 4
Purpose of Action	LEVEL 2
Deficiency Photo 1	
Deficiency Photo 2	Exit 3
Violations	No photo recorded No violations recorded
EXTERIOR WALLS	Inspected
Material Type(s)	Concrete, Masonry
Replacement Quantity	31,000
Replacement Uom	S.F.
Instance on All Facades	Inspected
Instance Condition	2- Between Good and Fair
Instance Quantity	31,000
Instance Quantity Uom	S.F.

**NYC Department of Education
Building Condition Assessment Survey 2023-2024**

Architectural Inspection

X167

Question

Response

EXTERIOR

EXTERIOR WALLS

Deficiency

CAST IN PLACE / PRE-CAST CONCRETE:MINOR
CRACKS/SPALLING

Roof Plan Reference

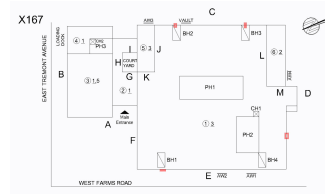

Elevation



Elevation Reference

Facade E, D and C

Deficiency Quantity

15

Quantity Uom

S.F.

Potential Action

REPAIR

Urgency of Action

PRIORITY 3

Purpose of Action

LEVEL 2

Deficiency Photo 1



Deficiency Photo 2

Facade E

No photo recorded

Violations

No violations recorded

EXTERIOR SOFFITS

Inspected

Condition

2- Between Good and Fair

Deficiency

No deficiencies recorded

LOADING DOCK

Inspected

Condition

3- Fair

Deficiency

CHEEK WALL/CRACKS, SPALLING - MAJOR

Deficiency Location/Instance

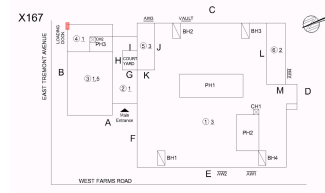

Deficiency Quantity

10

Quantity Uom

S.F.

Potential Action

REPLACE

Urgency of Action

PRIORITY 4



Purpose of Action

LEVEL 2

**NYC Department of Education
Building Condition Assessment Survey 2023-2024**

Architectural Inspection

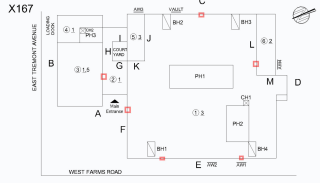

X167

Question	Response
EXTERIOR	
LOADING DOCK	
Deficiency Photo 1	
Deficiency Photo 2	Loading Dock wall
Violations	No photo recorded No violations recorded
LOUVER	Inspected
Condition	2- Between Good and Fair
Deficiency	No deficiencies recorded
PARAPETS	Inspected
Material Type(s)	Concrete
Replacement Quantity	8,000
Replacement Uom	C.F.
Instance on All Facades	Inspected
Instance Condition	2- Between Good and Fair
Instance Quantity	8,000
Instance Quantity Uom	CF
Deficiency	CONCRETE:MINOR CRACKS, SPALLING
Deficiency Location/Instance	
Deficiency Quantity	20
Quantity Uom	S.F.
Potential Action	REPAIR
Urgency of Action	PRIORITY 3
Purpose of Action	LEVEL 2
Deficiency Photo 1	
Deficiency Photo 2	Facade L
Violations	No photo recorded No violations recorded
PLAZA DECK	Does not exist
ROOF	Inspected
ROOFING	Inspected
ROOF HATCH/SMOKE HATCH	Does not exist
LEADERS, GUTTERS, DOWNSPOUTS, SCUPPERS	Does not exist
ROOF BARRIER/FENCE	Inspected
Condition	2- Between Good and Fair
Deficiency	No deficiencies recorded

**NYC Department of Education
Building Condition Assessment Survey 2023-2024**

Architectural Inspection

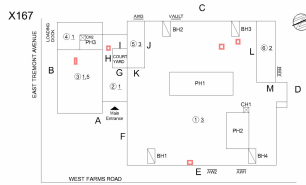
X167

Question	Response
EXTERIOR	
ROOF	
ROOFING	
ROOF CAGE	Does not exist
ROOFING	Inspected
Replacement Quantity	66,000
Replacement Uom	S.F.
Instance on Built-Up:All Roofs	Inspected
Instance Roof Photo	
	Roof 1
Instance Condition	3- Fair
Instance Quantity	66,000
Instance Quantity Uom	S.F.
Does the roof have major mechanical equipment sitting on Dunnage Steel less than 18" above the Roofing?	No
Does this Roof Instance have a Sustainable Roof System?	No
Do solar panels exist on these roofs?	No
Is/Are the roof(s) suitable for Solar Panel installation?	No
Installation Year	2006
Source of Installation Year	Documented
Deficiency	BUILT-UP:ROOFING:LOSS OF GRAVEL
Deficiency Location/Instance	
Deficiency Quantity	50
Quantity Uom	S.F.
Potential Action	INSTALL NEW GRAVEL
Urgency of Action	PRIORITY 3
Purpose of Action	LEVEL 2
Deficiency Photo 1	
Deficiency Photo 2	No photo recorded
Violations	No violations recorded
ROOFING DRAINS	Inspected
Condition	5- Poor
Deficiency	DETERIORATED

**NYC Department of Education
Building Condition Assessment Survey 2023-2024**

Architectural Inspection

X167

Question

Response

EXTERIOR

ROOF

ROOFING

ROOFING DRAINS

Deficiency Location/Instance

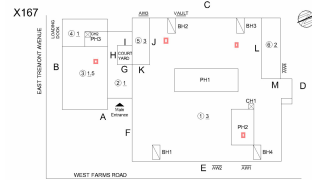

Deficiency Quantity

4

Quantity Uom

EACH

Potential Action

REPLACE

Urgency of Action

PRIORITY 4

Purpose of Action

LEVEL 2

Deficiency Photo 1



Deficiency Photo 2

Roof 1

Violations

No photo recorded

No violations recorded

SPECIALTIES

BULKHEAD/PENTHOUSE

Condition

Inspected

Deficiency

Inspected

Deficiency Location/Instance

3- Fair

**BULKHEAD/PENTHOUSE CEILING:PLASTER
DAMAGED/DETERIORATED**

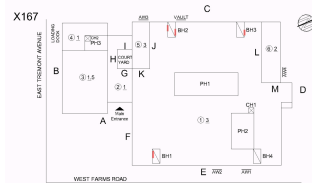

Deficiency Quantity

25

Quantity Uom

S.F.

Potential Action

MAINTENANCE

Urgency of Action

PRIORITY 3

Purpose of Action

LEVEL 2

Deficiency Photo 1



Deficiency Photo 2

Bulkhead BH3

Violations

No photo recorded

No violations recorded

Deficiency

BULKHEAD/PENTHOUSE ROOF:MINOR LEAKAGE

**NYC Department of Education
Building Condition Assessment Survey 2023-2024**

Architectural Inspection

X167

Question

Response

EXTERIOR

ROOF

SPECIALTIES

BULKHEAD/PENTHOUSE

Deficiency Location/Instance

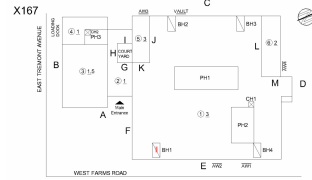

Deficiency Quantity
Quantity Uom
Potential Action
Urgency of Action
Purpose of Action
Deficiency Photo 1

25
S.F.
MAINTENANCE
PRIORITY 5
LEVEL 2



Deficiency Photo 2
Violations

Bulkhead BH1
No photo recorded
No violations recorded

CUPOLA/ SPIRES/ TOWERS

Does not exist

DORMER

Does not exist

DUNNAGE STEEL

Inspected

Condition

2- Between Good and Fair

Deficiency

No deficiencies recorded

SKYLIGHT/ROOF VENT

Does not exist

ROOF/GRAVITY TANK

Does not exist

STAIRS/RAMPS: EXTERIOR

Inspected

BUILDING CHEEK/FLANK WALLS

Inspected

Condition

2- Between Good and Fair

Deficiency

No deficiencies recorded

RAILINGS

Inspected

Condition

4- Between Fair and Poor

Deficiency

DAMAGED

Deficiency Location/Instance

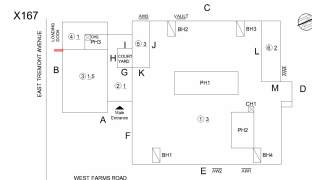

Deficiency Quantity
Quantity Uom
Potential Action
Urgency of Action
Purpose of Action

12
L.F.
REPLACE
PRIORITY 5
LEVEL 6

**NYC Department of Education
Building Condition Assessment Survey 2023-2024**

Architectural Inspection

X167

Question	Response
----------	----------

EXTERIOR

STAIRS/RAMPS: EXTERIOR

RAILINGS

Deficiency Photo 1



Exit 10

Deficiency Photo 2

No photo recorded

Violations

No violations recorded

Deficiency

RUST - MAJOR

Deficiency Location/Instance

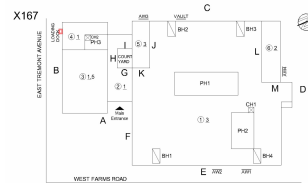

Deficiency Quantity

5

Quantity Uom

L.F.

Potential Action

REPLACE

Urgency of Action

PRIORITY 4

Purpose of Action

LEVEL 2

Deficiency Photo 1



Exit 10

Deficiency Photo 2

No photo recorded

Violations

No violations recorded

STAIRS/RAMPS

Inspected

Condition

2- Between Good and Fair

Deficiency

No deficiencies recorded

WINDOWS

Inspected

Replacement Quantity

7,500

Replacement Uom

S.F.

EXTERIOR GUARDS

Inspected

Condition

3- Fair

Deficiency

RUST - MAJOR

Roof Plan Reference

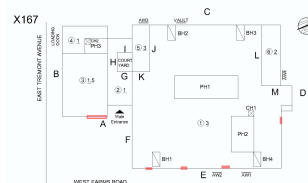

**NYC Department of Education
Building Condition Assessment Survey 2023-2024**

Architectural Inspection

X167

Question	Response
----------	----------

EXTERIOR

WINDOWS

EXTERIOR GUARDS

Elevation



Deficiency Quantity
Quantity Uom
Potential Action
Urgency of Action
Purpose of Action
Deficiency Photo 1

20
S.F.
REPLACE
PRIORITY 3
LEVEL 2



Deficiency Photo 2
Violations

Facade A
No photo recorded
No violations recorded

LINTELS

Condition

Inspected

Deficiency

2- Between Good and Fair

No deficiencies recorded

WINDOWS

Material Type(s)

Inspected

Instance on Aluminum - Other:All Facades

Aluminum

Instance Condition

Inspected

Instance Quantity

3- Fair

Instance Quantity Uom

7,500

Installation Year

S.F.

Source of Installation Year

2006

Are these windows insulated?

Documented

Deficiency

Yes

Roof Plan Reference

ALUMINUM - OTHER: BROKEN PANE

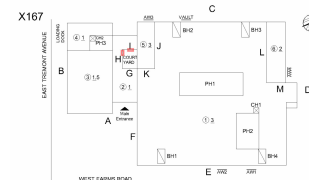

Elevation

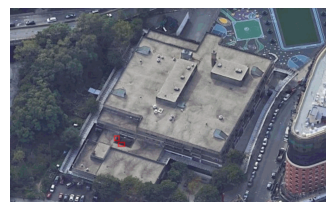

Elevation Reference
Deficiency Quantity
Quantity Uom
Potential Action

Facade H and I
75
S.F.
MAINTENANCE

**NYC Department of Education
Building Condition Assessment Survey 2023-2024**

Architectural Inspection



X167

Question	Response
EXTERIOR	
WINDOWS	
WINDOWS	
Urgency of Action	PRIORITY 5
Purpose of Action	LEVEL 2
Deficiency Photo 1	
Deficiency Photo 2	Staff Cafeteria shown, also Lobby and Corridor to Staff Cafeteria (courtyard facades)
Violations	No photo recorded No violations recorded
INTERIOR	
POOLS	
Does not exist	
STRUCTURAL	
COLUMNS/BEAMS/BEARING WALLS	
Condition	Inspected
Deficiency	3- Fair
Deficiency Location/Instance	MASONRY BEARING WALL:CRACKED/SPALLED
Deficiency Quantity	Basement
Quantity Uom	175
Potential Action	S.F.
Urgency of Action	RESTITCH
Purpose of Action	PRIORITY 3
Deficiency Photo 1	LEVEL 5
Deficiency Photo 2	
Violations	Room C12 shown, also Rooms C1, C3, C15, C18, C22, C31, C33, Custodian Shop, Electrical Room, Stair A/B and Corridor near Room C29 No photo recorded No violations recorded
FLOOR STRUCTURE	
Condition	Inspected
Deficiency	2- Between Good and Fair
Deficiency	No deficiencies recorded
FOUNDATION WALLS	
Material Type(s)	Inspected
Condition	Concrete
Deficiency	2- Between Good and Fair
Deficiency	No deficiencies recorded
ROOF STRUCTURE	
Condition	Inspected
Deficiency	3- Fair
Deficiency Location/Instance	STEEL COLUMNS/BEAMS:DETERIORATED/MISSING
Deficiency Quantity	SPRAY-ON FIREPROOFING
Quantity Uom	Roof
	25
	S.F.

**NYC Department of Education
Building Condition Assessment Survey 2023-2024**

Architectural Inspection



X167

Question	Response
INTERIOR	
STRUCTURAL	
ROOF STRUCTURE	
Potential Action	REPLACE
Urgency of Action	PRIORITY 3
Purpose of Action	LEVEL 5
Deficiency Photo 1	
Deficiency Photo 2	Penthouse PH1
Violations	No photo recorded
	No violations recorded
VAULTS-BUNKERS	
	Inspected
Foundation Walls	Inspected
Condition	3- Fair
Deficiency	CRACKS, SPALLING
Deficiency Location/Instance	Basement vault
Deficiency Quantity	25
Quantity Uom	S.F.
Potential Action	REPAIR
Urgency of Action	PRIORITY 3
Purpose of Action	LEVEL 5
Deficiency Photo 1	
Deficiency Photo 2	Vault Wall
Violations	No photo recorded
	No violations recorded
Slab Structure	
	Inspected
Condition	3- Fair
Deficiency	CONCRETE BEAMS:CRACKS/SPALLED/REINFORCEMENT EXPOSED
Deficiency Location/Instance	Basement vault
Deficiency Quantity	25
Quantity Uom	S.F.
Potential Action	REPAIR
Urgency of Action	PRIORITY 3
Purpose of Action	LEVEL 5
Deficiency Photo 1	

**NYC Department of Education
Building Condition Assessment Survey 2023-2024**

Architectural Inspection

X167

Question	Response
INTERIOR	
STRUCTURAL	
VAULTS-BUNKERS	
Slab Structure	
Deficiency Photo 2	Vault slab
Violations	No photo recorded No violations recorded
Vault/Ash Hoist Doors and Framing	Inspected
Condition	5- Poor
Deficiency	DETERIORATED/DAMAGED VAULT/ASH HOIST DOORS AND FRAMING
Deficiency Location/Instance	Basement
Deficiency Quantity	2
Quantity Uom	EACH
Potential Action	REPLACE
Urgency of Action	PRIORITY 3
Purpose of Action	LEVEL 2
Deficiency Photo 1	
Deficiency Photo 2	Vault doors
Violations	No photo recorded No violations recorded
Deficiency	WATER INFILTRATION
Deficiency Location/Instance	Basement
Deficiency Quantity	10
Quantity Uom	S.F.
Potential Action	REPAIR
Urgency of Action	PRIORITY 5
Purpose of Action	LEVEL 2
Deficiency Photo 1	
Deficiency Photo 2	Vault Doors
Violations	No photo recorded No violations recorded
AUDITORIUM	
Instance on 2nd Floor (603 Seats)	Inspected
Ceiling	Inspected
Instance on 2nd Floor (603 Seats)	Inspected
Instance Condition	2- Between Good and Fair
Deficiency	No deficiencies recorded
Door(s)	Inspected
Instance on 2nd Floor (603 Seats)	Inspected
Instance Condition	2- Between Good and Fair

**NYC Department of Education
Building Condition Assessment Survey 2023-2024**

Architectural Inspection



X167

Question	Response
INTERIOR	
AUDITORIUM	
Door(s)	
Deficiency	No deficiencies recorded
Fixed H/C Lift	
Instance on 2nd Floor (603 Seats)	Inspected
Instance Condition	2- Between Good and Fair
Deficiency	No deficiencies recorded
Fixed Seating	
Instance on 2nd Floor (603 Seats)	Inspected
Instance Condition	3- Fair
Deficiency	DAMAGED/BROKEN/INOPERABLE
Deficiency Location/Instance	Seats A/2,101, B/105,107,109, and others
Deficiency Quantity	25
Quantity Uom	EACH
Potential Action	REPLACE
Urgency of Action	PRIORITY 3
Purpose of Action	LEVEL 2
Deficiency Photo 1	
Deficiency Photo 2	Seat B/109
Violations	No photo recorded No violations recorded
Floor Finish	
Instance on 2nd Floor (603 Seats)	Inspected
Instance Condition	2- Between Good and Fair
Deficiency	VINYL TILES:DETERIORATED SUBSTRATE
Deficiency Location/Instance	Near SFP Tracks
Deficiency Quantity	30
Quantity Uom	S.F.
Potential Action	REPLACE
Urgency of Action	PRIORITY 3
Purpose of Action	LEVEL 2
Deficiency Photo 1	
Deficiency Photo 2	Near SFP Tracks
Violations	No photo recorded No violations recorded
Sliding-folding Partition	
Instance on 2nd Floor (603 Seats)	Does not exist
Stage	
Instance on 2nd Floor (603 Seats)	Inspected
Stage	

**NYC Department of Education
Building Condition Assessment Survey 2023-2024**

Architectural Inspection

X167

Question	Response
INTERIOR	
AUDITORIUM	
Stage	
Stage	
Instance on 2nd Floor (603 Seats)	Inspected
Instance Condition	2- Between Good and Fair
Deficiency	DAMAGED STEPS
Deficiency Location/Instance	Stage Left
Deficiency Quantity	10
Quantity Uom	S.F.
Potential Action	REPLACE
Urgency of Action	PRIORITY 3
Purpose of Action	LEVEL 2
Deficiency Photo 1	
Deficiency Photo 2	Stage Left
Violations	No photo recorded
	No violations recorded
Stage Curtain Rigging	
Instance on 2nd Floor (603 Seats)	Inspected
Instance Condition	2- Between Good and Fair
Deficiency	No deficiencies recorded
Stage Curtains	
Instance on 2nd Floor (603 Seats)	Inspected
Instance Condition	2- Between Good and Fair
Deficiency	No deficiencies recorded
Walls	
Instance on 2nd Floor (603 Seats)	Inspected
Instance Condition	2- Between Good and Fair
Deficiency	MASONRY:CRACKS/SPALLING
Deficiency Location/Instance	Near Dressing Room
Deficiency Quantity	10
Quantity Uom	S.F.
Potential Action	REPLACE
Urgency of Action	PRIORITY 3
Purpose of Action	LEVEL 2
Deficiency Photo 1	
Deficiency Photo 2	Near Dressing Room
Violations	No photo recorded
	No violations recorded
Deficiency	PLASTER:CRACKS/SPALLING
Deficiency Location/Instance	Middle Left, Right Exit Vestibule

**NYC Department of Education
Building Condition Assessment Survey 2023-2024**

Architectural Inspection

X167

Question	Response
INTERIOR	
AUDITORIUM	
Walls	
Deficiency Quantity	20
Quantity Uom	S.F.
Potential Action	REPLACE
Urgency of Action	PRIORITY 3
Purpose of Action	LEVEL 2
Deficiency Photo 1	
Deficiency Photo 2	Middle Left Exit Vestibule
Violations	No photo recorded No violations recorded
Window Curtains/Shades/Blinds	
Instance on 2nd Floor (603 Seats)	Does not exist
CAFETERIA	Inspected
Instance on 1st Floor - Students	Inspected
Instance on 1st Floor - Staff (600 SF)	Inspected
Ceiling	
Instance on 1st Floor - Students	Inspected
Instance Condition	2- Between Good and Fair
Deficiency	No deficiencies recorded
Instance on 1st Floor - Staff (600 SF)	Inspected
Instance Condition	3- Fair
Deficiency	ACOUSTIC TILES:DAMAGED/MISSING
Deficiency Location/Instance	Near Entrance, rear
Deficiency Quantity	20
Quantity Uom	S.F.
Potential Action	REPLACE
Urgency of Action	PRIORITY 3
Purpose of Action	LEVEL 2
Deficiency Photo 1	
Deficiency Photo 2	Rear
Violations	No photo recorded No violations recorded
Door(s)	
Instance on 1st Floor - Students	Inspected
Instance Condition	2- Between Good and Fair
Deficiency	No deficiencies recorded
Instance on 1st Floor - Staff (600 SF)	Inspected
Instance Condition	3- Fair
Deficiency	WOOD:DETERIORATED DOOR

**NYC Department of Education
Building Condition Assessment Survey 2023-2024**

Architectural Inspection

X167

Question	Response
INTERIOR	
CAFETERIA	
Door(s)	
Deficiency Location/Instance	Entrance
Deficiency Quantity	1
Quantity Uom	EACH
Potential Action	MAINTENANCE
Urgency of Action	PRIORITY 3
Purpose of Action	LEVEL 2
Deficiency Photo 1	
Deficiency Photo 2	Entrance
Violations	No photo recorded No violations recorded
Fixed Equipment	
Instance on 1st Floor - Students	Does not exist
Instance on 1st Floor - Staff (600 SF)	Does not exist
Floor Finish	
Instance on 1st Floor - Students	Inspected
Instance Condition	2- Between Good and Fair
Deficiency	No deficiencies recorded
Instance on 1st Floor - Staff (600 SF)	Inspected
Instance Condition	2- Between Good and Fair
Deficiency	VINYL TILES:BROKEN/DETERIORATED/MISSING TILES
Deficiency Location/Instance	Near Entrance
Deficiency Quantity	10
Quantity Uom	S.F.
Potential Action	REPLACE
Urgency of Action	PRIORITY 3
Purpose of Action	LEVEL 2
Deficiency Photo 1	
Deficiency Photo 2	Near Entrance
Violations	No photo recorded No violations recorded
Sliding-folding Partition	
Instance on 1st Floor - Students	Does not exist
Instance on 1st Floor - Staff (600 SF)	Does not exist
Stage	
Instance on 1st Floor - Students	Does not exist
Instance on 1st Floor - Staff (600 SF)	Does not exist
Walls	
Instance on 1st Floor - Students	Inspected

**NYC Department of Education
Building Condition Assessment Survey 2023-2024**

Architectural Inspection



X167

Question	Response
INTERIOR	
CAFETERIA	
Walls	
Instance Condition	2- Between Good and Fair
Deficiency	No deficiencies recorded
Instance on 1st Floor - Staff (600 SF)	Inspected
Instance Condition	2- Between Good and Fair
Deficiency	PLASTER:CRACKS/SPALLING
Deficiency Location/Instance	Rear
Deficiency Quantity	10
Quantity Uom	S.F.
Potential Action	REPLACE
Urgency of Action	PRIORITY 3
Purpose of Action	LEVEL 2
Deficiency Photo 1	
Deficiency Photo 2	No photo recorded
Violations	No violations recorded
Window Curtains/Shades/Blinds	
Instance on 1st Floor - Students	Does not exist
Instance on 1st Floor - Staff (600 SF)	Does not exist
CLASSROOMS/CORRIDORS/ADMIN SPACES	
Ceiling	Inspected
Condition	2- Between Good and Fair
Deficiency	ACOUSTIC TILES:DAMAGED/MISSING
Deficiency Location/Instance	Rooms 100, 103, 105, Corridor near Rooms 109, 146, and others
Deficiency Quantity	200
Quantity Uom	S.F.
Potential Action	REPLACE
Urgency of Action	PRIORITY 3
Purpose of Action	LEVEL 2
Deficiency Photo 1	
Deficiency Photo 2	Room 105
Violations	No photo recorded
Violations	No violations recorded
Deficiency	ACOUSTIC TILES ON PLASTER:DAMAGED/MISSING
Deficiency Location/Instance	Room 146
Deficiency Quantity	10
Quantity Uom	S.F.
Potential Action	REPLACE
Urgency of Action	PRIORITY 3
Purpose of Action	LEVEL 2

**NYC Department of Education
Building Condition Assessment Survey 2023-2024**

Architectural Inspection

X167

Question	Response
INTERIOR	
CLASSROOMS/CORRIDORS/ADMIN SPACES	
Ceiling	
Deficiency Photo 1	
Deficiency Photo 2	Room 146
Violations	No photo recorded No violations recorded
Door(s)	Inspected
Condition	5- Poor
Deficiency	WOOD:DETERIORATED DOOR
Deficiency Location/Instance	Rooms 212, 262, 304, 341, 342, and others
Deficiency Quantity	10
Quantity Uom	EACH
Potential Action	MAINTENANCE
Urgency of Action	PRIORITY 3
Purpose of Action	LEVEL 2
Deficiency Photo 1	
Deficiency Photo 2	Room 304
Violations	No photo recorded No violations recorded
Deficiency	METAL:DETERIORATED DOOR
Deficiency Location/Instance	Room 311
Deficiency Quantity	1
Quantity Uom	EACH
Potential Action	MAINTENANCE
Urgency of Action	PRIORITY 3
Purpose of Action	LEVEL 2
Deficiency Photo 1	
Deficiency Photo 2	Room 311
Violations	No photo recorded No violations recorded
Floor Finish	Inspected
Condition	2- Between Good and Fair
Deficiency	VINYL TILES:DETERIORATED SUBSTRATE

**NYC Department of Education
Building Condition Assessment Survey 2023-2024**

Architectural Inspection

X167

Question	Response
----------	----------

INTERIOR

CLASSROOMS/CORRIDORS/ADMIN SPACES

Floor Finish

Deficiency Location/Instance	Corridor near Rooms C17, C18, 106, 163, Near Staff Cafeteria, and others
Deficiency Quantity	200
Quantity Uom	S.F.
Potential Action	REPLACE
Urgency of Action	PRIORITY 3
Purpose of Action	LEVEL 2
Deficiency Photo 1	

Deficiency Photo 2	Corridor near Room 163
Violations	No photo recorded No violations recorded

Deficiency	QUARRY TILE:BROKEN/MISSING TILES
Deficiency Location/Instance	Main Entrance Lobby
Deficiency Quantity	10
Quantity Uom	S.F.
Potential Action	REPLACE
Urgency of Action	PRIORITY 3
Purpose of Action	LEVEL 2
Deficiency Photo 1	

Deficiency Photo 2	Main Entrance Lobby
Violations	No photo recorded No violations recorded

Walls

Condition	Inspected
	2- Between Good and Fair

Deficiency	PLASTER:CRACKS/SPALLING
Deficiency Location/Instance	Corridor near Stair AB/2
Deficiency Quantity	10
Quantity Uom	S.F.
Potential Action	REPLACE
Urgency of Action	PRIORITY 3
Purpose of Action	LEVEL 2
Deficiency Photo 1	

**NYC Department of Education
Building Condition Assessment Survey 2023-2024**

Architectural Inspection



X167

Question	Response
INTERIOR	
CLASSROOMS/CORRIDORS/ADMIN SPACES	
Walls	
Corridor near Stair AB/2	Corridor near Stair AB/2
Deficiency Photo 2	No photo recorded
Violations	No violations recorded
Deficiency	MIRRORS:BROKEN/DAMAGED
Deficiency Location/Instance	Dance Room
Deficiency Quantity	20
Quantity Uom	S.F.
Potential Action	REPLACE
Urgency of Action	PRIORITY 3
Purpose of Action	LEVEL 2
Deficiency Photo 1	
Deficiency Photo 2	Dance Room
Violations	No photo recorded
	No violations recorded
Specialties	Inspected
Classroom Locker(s)	Inspected
Condition	2- Between Good and Fair
Deficiency	DAMAGED UNITS
Deficiency Location/Instance	Near Staff Cafeteria
Deficiency Quantity	2
Quantity Uom	EACH
Potential Action	REPLACE
Urgency of Action	PRIORITY 3
Purpose of Action	LEVEL 2
Deficiency Photo 1	
Deficiency Photo 2	Near Staff Cafeteria
Violations	No photo recorded
	No violations recorded
Fixed Seating	Does not exist
GYMNASIUM	Inspected
Instance on Basement	Inspected
Ceiling	Inspected
Instance on Basement	Inspected
Instance Condition	2- Between Good and Fair
Deficiency	TECTUM:DAMAGED/MISSING
Deficiency Location/Instance	Center
Deficiency Quantity	50
Quantity Uom	S.F.
Potential Action	REPLACE

**NYC Department of Education
Building Condition Assessment Survey 2023-2024**

Architectural Inspection

X167

Question	Response
INTERIOR	
GYMNASIUM	
Ceiling	
Urgency of Action	PRIORITY 3
Purpose of Action	LEVEL 2
Deficiency Photo 1	
Deficiency Photo 2	Center
Violations	No photo recorded No violations recorded
Door(s)	
Instance on Basement	Inspected
Instance Condition	2- Between Good and Fair
Deficiency	No deficiencies recorded
Fixed Equipment	
Instance on Basement	Inspected
Instance Condition	2- Between Good and Fair
Deficiency	No deficiencies recorded
Floor Finish	
Instance on Basement	Inspected
Instance Condition	2- Between Good and Fair
Deficiency	WOOD:DAMAGED/DETERIORATED
Deficiency Location/Instance	Near Drinking Fountain
Deficiency Quantity	20
Quantity Uom	S.F.
Potential Action	REPLACE
Urgency of Action	PRIORITY 3
Purpose of Action	LEVEL 2
Deficiency Photo 1	
Deficiency Photo 2	Near Drinking Fountain
Violations	No photo recorded No violations recorded
Seating	
Instance on Basement	Inspected
Instance Condition	5- Poor
Deficiency	INOPERABLE BLEACHERS
Deficiency Location/Instance	North Side
Deficiency Quantity	500
Quantity Uom	S.F.
Potential Action	REPLACE
Urgency of Action	PRIORITY 3
Purpose of Action	LEVEL 2

**NYC Department of Education
Building Condition Assessment Survey 2023-2024**

Architectural Inspection



X167

Question	Response
INTERIOR	
GYMNASIUM	
Seating	
Deficiency Photo 2	No photo recorded
Violations	No violations recorded
Sliding-folding Partition	
Instance on Basement	Inspected
Instance Condition	3- Fair
Deficiency	MOVABLE PANELS:DAMAGED
Deficiency Location/Instance	Center
Deficiency Quantity	40
Quantity Uom	S.F.
Potential Action	REPLACE
Urgency of Action	PRIORITY 3
Purpose of Action	LEVEL 2
Deficiency Photo 2	No photo recorded
Violations	No violations recorded
Stage	
Instance on Basement	Does not exist
Walls	
Instance on Basement	Inspected
Instance Condition	2- Between Good and Fair
Deficiency	MASONRY:CRACKS/SPALLING
Deficiency Location/Instance	East, West Side
Deficiency Quantity	80
Quantity Uom	S.F.
Potential Action	REPLACE
Urgency of Action	PRIORITY 3
Purpose of Action	LEVEL 2
Deficiency Photo 1	
	East Side
Deficiency Photo 2	No photo recorded
Violations	No violations recorded
Window Curtains/Shades/Blinds	
Instance on Basement	Does not exist
INTERIOR DOOR HARDWARE	
Condition	Inspected
Deficiency	3- Fair
Deficiency	No deficiencies recorded
INTERIOR GUARDS	
Condition	Inspected
Deficiency	2- Between Good and Fair
Deficiency	DETERIORATED/TORN-OUT/MISSING
Deficiency Location/Instance	Boys Locker Room
Deficiency Quantity	20
Quantity Uom	S.F.
Potential Action	REPLACE
Urgency of Action	PRIORITY 3
Purpose of Action	LEVEL 2

**NYC Department of Education
Building Condition Assessment Survey 2023-2024**

Architectural Inspection

X167

Question	Response
INTERIOR	
INTERIOR GUARDS	
Deficiency Photo 1	
Deficiency Photo 2	Boys Locker Room
Violations	No photo recorded No violations recorded
KITCHEN	
Instance on 1st Floor	Inspected
Ceiling	Inspected
Instance on 1st Floor	Inspected
Instance Condition	2- Between Good and Fair
Deficiency	METAL PAN:DAMAGED/MISSING
Deficiency Location/Instance	Prep Area
Deficiency Quantity	10
Quantity Uom	S.F.
Potential Action	REPLACE
Urgency of Action	PRIORITY 3
Purpose of Action	LEVEL 2
Deficiency Photo 1	
Deficiency Photo 2	Prep Area
Violations	No photo recorded No violations recorded
Door(s)	
Instance on 1st Floor	Inspected
Instance Condition	2- Between Good and Fair
Deficiency	No deficiencies recorded
Floor Finish	
Instance on 1st Floor	Inspected
Instance Condition	2- Between Good and Fair
Deficiency	QUARRY TILE:BROKEN/MISSING TILES
Deficiency Location/Instance	Prep Area
Deficiency Quantity	10
Quantity Uom	S.F.
Potential Action	REPLACE
Urgency of Action	PRIORITY 3
Purpose of Action	LEVEL 2

**NYC Department of Education
Building Condition Assessment Survey 2023-2024**

Architectural Inspection

X167

Question	Response
INTERIOR	
KITCHEN	
Floor Finish	
Deficiency Photo 1	
	Prep Area
Deficiency Photo 2	No photo recorded
Violations	No violations recorded
Deficiency	CONCRETE:CRACKS
Deficiency Location/Instance	Storage Room
Deficiency Quantity	10
Quantity Uom	S.F.
Potential Action	REPLACE
Urgency of Action	PRIORITY 3
Purpose of Action	LEVEL 2
Deficiency Photo 1	
	Storage Room
Deficiency Photo 2	No photo recorded
Violations	No violations recorded
Walls	
Instance on 1st Floor	Inspected
Instance Condition	2- Between Good and Fair
Deficiency	CERAMIC TILE:BROKEN/ MISSING
Deficiency Location/Instance	Near Windows
Deficiency Quantity	10
Quantity Uom	S.F.
Potential Action	REPLACE
Urgency of Action	PRIORITY 3
Purpose of Action	LEVEL 2
Deficiency Photo 1	
	Near Windows
Deficiency Photo 2	No photo recorded
Violations	No violations recorded
LIBRARY	
Instance on Room 231	Inspected
	Inspected
Built-in Furnishing	

**NYC Department of Education
Building Condition Assessment Survey 2023-2024**

Architectural Inspection

X167

Question	Response
INTERIOR	
LIBRARY	
Built-in Furnishing	
Instance on Room 231	Inspected
Instance Condition	2- Between Good and Fair
Deficiency	No deficiencies recorded
Ceiling	
Instance on Room 231	Inspected
Instance Condition	2- Between Good and Fair
Deficiency	No deficiencies recorded
Door(s)	
Instance on Room 231	Inspected
Instance Condition	2- Between Good and Fair
Deficiency	No deficiencies recorded
Floor Finish	
Instance on Room 231	Inspected
Instance Condition	2- Between Good and Fair
Deficiency	No deficiencies recorded
Walls	
Instance on Room 231	Inspected
Instance Condition	2- Between Good and Fair
Deficiency	No deficiencies recorded
LOCKER ROOM	
Instance on Basement - Girls (908 Lockers)	Inspected
Alternative Use	No
Instance on Basement - Boys (142 Lockers)	Inspected
Alternative Use	No
Ceiling	
Instance on Basement - Girls (908 Lockers)	Inspected
Instance Condition	2- Between Good and Fair
Deficiency	No deficiencies recorded
Instance on Basement - Boys (142 Lockers)	Inspected
Instance Condition	2- Between Good and Fair
Deficiency	No deficiencies recorded
Door(s)	
Instance on Basement - Girls (908 Lockers)	Inspected
Instance Condition	3- Fair
Deficiency	WOOD:DETERIORATED DOOR
Deficiency Location/Instance	Entrance
Deficiency Quantity	1
Quantity Uom	EACH
Potential Action	MAINTENANCE
Urgency of Action	PRIORITY 3
Purpose of Action	LEVEL 2
Deficiency Photo 1	
Deficiency Photo 2	Entrance No photo recorded

**NYC Department of Education
Building Condition Assessment Survey 2023-2024**

Architectural Inspection

X167

Question	Response
INTERIOR	
LOCKER ROOM	
Door(s)	
Violations	No violations recorded
Instance on Basement - Boys (142 Lockers)	Inspected
Instance Condition	3- Fair
Deficiency	WOOD:DETERIORATED DOOR
Deficiency Location/Instance	Entrance
Deficiency Quantity	1
Quantity Uom	EACH
Potential Action	MAINTENANCE
Urgency of Action	PRIORITY 3
Purpose of Action	LEVEL 2
Deficiency Photo 1	
Deficiency Photo 2	No photo recorded
Violations	No violations recorded
Floor Finish	
Instance on Basement - Girls (908 Lockers)	Inspected
Instance Condition	2- Between Good and Fair
Deficiency	No deficiencies recorded
Instance on Basement - Boys (142 Lockers)	Inspected
Instance Condition	2- Between Good and Fair
Deficiency	No deficiencies recorded
Locker Room Lockers	
Instance on Basement - Girls (908 Lockers)	Inspected
Instance Condition	3- Fair
Deficiency	DAMAGED UNITS
Deficiency Location/Instance	Lockers 360,496,504,882,888, and others
Deficiency Quantity	30
Quantity Uom	EACH
Potential Action	REPLACE
Urgency of Action	PRIORITY 3
Purpose of Action	LEVEL 2
Deficiency Photo 1	
Deficiency Photo 2	Locker 504
Violations	No photo recorded
Violations	No violations recorded
Instance on Basement - Boys (142 Lockers)	Inspected
Instance Condition	5- Poor
Deficiency	DAMAGED UNITS

**NYC Department of Education
Building Condition Assessment Survey 2023-2024**

Architectural Inspection

X167

Question	Response
INTERIOR	
LOCKER ROOM	
Locker Room Lockers	
Deficiency Location/Instance	Lockers 281, 795, 802, 856, 904
Deficiency Quantity	20
Quantity Uom	EACH
Potential Action	REPLACE
Urgency of Action	PRIORITY 3
Purpose of Action	LEVEL 2
Deficiency Photo 1	
	Locker 802
Deficiency Photo 2	No photo recorded
Violations	No violations recorded
Walls	
Instance on Basement - Girls (908 Lockers)	Inspected
Instance Condition	2- Between Good and Fair
Deficiency	No deficiencies recorded
Instance on Basement - Boys (142 Lockers)	Inspected
Instance Condition	2- Between Good and Fair
Deficiency	MASONRY:CRACKS/SPALLING
Deficiency Location/Instance	Near Toilet
Deficiency Quantity	10
Quantity Uom	S.F.
Potential Action	REPLACE
Urgency of Action	PRIORITY 3
Purpose of Action	LEVEL 2
Deficiency Photo 1	
	Near Toilet
Deficiency Photo 2	No photo recorded
Violations	No violations recorded
MULTI-PURPOSE ROOM	Does not exist
SCIENCE DEMO ROOM	Inspected
Instance on Room 254	Inspected
Alternative Use	No
Fixed Equipment	
Instance on Room 254	Inspected
Instance Condition	2- Between Good and Fair
Deficiency	CABINERY:MISSING/DAMAGED
Deficiency Location/Instance	Room 254
Deficiency Quantity	2
Quantity Uom	L.F.

**NYC Department of Education
Building Condition Assessment Survey 2023-2024**

Architectural Inspection

X167

Question	Response
INTERIOR	
SCIENCE DEMO ROOM	
Fixed Equipment	
Potential Action	REPLACE
Urgency of Action	PRIORITY 3
Purpose of Action	LEVEL 2
Deficiency Photo 1	
Deficiency Photo 2	Room 254 No photo recorded
Violations	No violations recorded
SCIENCE LAB	
Instance on Rooms 103, 105, 203, 205, 303, 305	Inspected
Alternative Use	Yes
Fixed Equipment	
Instance on Rooms 103, 105, 203, 205, 303, 305	Inspected
Instance Condition	3- Fair
Deficiency	CABINETRY:MISSING/DAMAGED
Deficiency Location/Instance	Rooms 103, 105, 203, 205, 303, 305
Deficiency Quantity	80
Quantity Uom	L.F.
Potential Action	REPLACE
Urgency of Action	PRIORITY 3
Purpose of Action	LEVEL 2
Deficiency Photo 2	No photo recorded
Violations	No violations recorded
SCIENCE PREP ROOM	
Instance on Room 254A	Inspected
Alternative Use	No
Fixed Equipment	
Instance on Room 254A	Inspected
Instance Condition	2- Between Good and Fair
Deficiency	No deficiencies recorded
SHOWER ROOM	
Instance on Basement - Boys	Inaccessible
Instance on Basement - Girls	Inaccessible
STAIRS/RAMPS: INTERIOR	
Do Letter Stair Signs Exist?	Inspected Yes
Ceiling	
Condition	Inspected 2- Between Good and Fair
Deficiency	No deficiencies recorded
Door(s)	
Condition	Inspected 2- Between Good and Fair
Deficiency	No deficiencies recorded
Partition	
Condition	Does not exist
Railings	
Condition	Inspected 2- Between Good and Fair
Deficiency	No deficiencies recorded
Stairs and Landings	
Condition	Inspected

**NYC Department of Education
Building Condition Assessment Survey 2023-2024**

Architectural Inspection



X167

Question	Response
INTERIOR	
STAIRS/RAMPS: INTERIOR	
Stairs and Landings	
Condition	2- Between Good and Fair
Deficiency	VINYL TILES:DETERIORATED SUBSTRATE
Deficiency Location/Instance	Stairs AB/1,2, C/1, D/1, EF/2
Deficiency Quantity	60
Quantity Uom	S.F.
Potential Action	REPLACE
Urgency of Action	PRIORITY 3
Purpose of Action	LEVEL 2
Deficiency Photo 1	
Deficiency Photo 2	Stair AB/2 No photo recorded
Violations	No violations recorded
Deficiency	STONE:BROKEN/MISSING
Deficiency Location/Instance	Stair AB/1
Deficiency Quantity	10
Quantity Uom	S.F.
Potential Action	REPLACE
Urgency of Action	PRIORITY 3
Purpose of Action	LEVEL 2
Deficiency Photo 1	
Deficiency Photo 2	Stair AB/1 No photo recorded
Violations	No violations recorded
Walls	Inspected
Condition	2- Between Good and Fair
Deficiency	No deficiencies recorded
TOILET ROOMS - STAFF	Inspected
Ceiling	Inspected
Condition	2- Between Good and Fair
Deficiency	No deficiencies recorded
Door(s)	Inspected
Condition	5- Poor
Deficiency	WOOD:DETERIORATED DOOR
Deficiency Location/Instance	Rooms 258, 260, Kitchen Staff Men, Women
Deficiency Quantity	4
Quantity Uom	EACH
Potential Action	MAINTENANCE
Urgency of Action	PRIORITY 3
Purpose of Action	LEVEL 2

**NYC Department of Education
Building Condition Assessment Survey 2023-2024**

Architectural Inspection



X167

Question	Response
INTERIOR	
TOILET ROOMS - STAFF	
Door(s)	
Deficiency Photo 1	
Deficiency Photo 2	Room 258
Violations	No photo recorded No violations recorded
Floor Finish	Inspected
Condition	2- Between Good and Fair
Deficiency	No deficiencies recorded
Stalls	Inspected
Condition	5- Poor
Deficiency	RUST - MAJOR
Deficiency Location/Instance	Rooms 258, 260, Kitchen Staff Men, Women
Deficiency Quantity	4
Quantity Uom	EACH
Potential Action	REPLACE
Urgency of Action	PRIORITY 3
Purpose of Action	LEVEL 2
Deficiency Photo 1	
Deficiency Photo 2	Room 258
Violations	No photo recorded No violations recorded
Walls	Inspected
Condition	2- Between Good and Fair
Deficiency	CERAMIC TILE:BROKEN/ MISSING
Deficiency Location/Instance	Room 258
Deficiency Quantity	10
Quantity Uom	S.F.
Potential Action	REPLACE
Urgency of Action	PRIORITY 3
Purpose of Action	LEVEL 2
Deficiency Photo 1	
	Room 258

**NYC Department of Education
Building Condition Assessment Survey 2023-2024**

Architectural Inspection



X167

Question	Response
INTERIOR	
TOILET ROOMS - STAFF	
Walls	
Deficiency Photo 2	No photo recorded
Violations	No violations recorded
TOILET ROOMS - STUDENTS	
Ceiling	Inspected
Condition	2- Between Good and Fair
Deficiency	No deficiencies recorded
Door(s)	Inspected
Condition	5- Poor
Deficiency	WOOD:DETERIORATED DOOR
Deficiency Location/Instance	3rd Floor Boys
Deficiency Quantity	1
Quantity Uom	EACH
Potential Action	MAINTENANCE
Urgency of Action	PRIORITY 3
Purpose of Action	LEVEL 2
Deficiency Photo 1	
Deficiency Photo 2	3rd Floor Boys
Violations	No photo recorded
Violations	No violations recorded
Deficiency	WOOD:DAMAGED LOUVER
Deficiency Location/Instance	Room 202
Deficiency Quantity	1
Quantity Uom	EACH
Potential Action	MAINTENANCE
Urgency of Action	PRIORITY 3
Purpose of Action	LEVEL 2
Deficiency Photo 1	
Deficiency Photo 2	Room 202
Violations	No photo recorded
Violations	No violations recorded
Floor Finish	Inspected
Condition	2- Between Good and Fair
Deficiency	CERAMIC TILE:BROKEN/MISSING TILES
Deficiency Location/Instance	Boys Locker Room, Girls Locker Room
Deficiency Quantity	10
Quantity Uom	S.F.
Potential Action	REPLACE
Urgency of Action	PRIORITY 3
Purpose of Action	LEVEL 2

**NYC Department of Education
Building Condition Assessment Survey 2023-2024**

Architectural Inspection

X167

Question	Response
INTERIOR	
TOILET ROOMS - STUDENTS	
Floor Finish	
Deficiency Photo 1	
Deficiency Photo 2	Boys Locker Room
Violations	No photo recorded No violations recorded
Stalls	Inspected
Condition	2- Between Good and Fair
Deficiency	No deficiencies recorded
Walls	Inspected
Condition	2- Between Good and Fair
Deficiency	CERAMIC TILE:BROKEN/ MISSING
Deficiency Location/Instance	Girls Locker Room
Deficiency Quantity	10
Quantity Uom	S.F.
Potential Action	REPLACE
Urgency of Action	PRIORITY 3
Purpose of Action	LEVEL 2
Deficiency Photo 1	
Deficiency Photo 2	Girls Locker Room
Violations	No photo recorded No violations recorded
LIFE SAFETY	Inspected
F.D. HOLDING AREA	Does not exist
STEEL STAIRS	Does not exist
SITE	Inspected
CONTAINERIZATION	Inspected
Condition	5- Poor
Deficiency	CONTAINER DAMAGED
Deficiency Location/Instance	Parking Lot
Deficiency Quantity	5
Quantity Uom	EACH
Potential Action	REPLACE
Urgency of Action	PRIORITY 3
Purpose of Action	LEVEL 2

**NYC Department of Education
Building Condition Assessment Survey 2023-2024**

Architectural Inspection



X167

Question	Response
SITE	
CONTAINERIZATION	
Deficiency Photo 1	
Deficiency Photo 2	Parking Lot
Violations	No photo recorded
Deficiency	No violations recorded
Deficiency Location/Instance	CONCRETE PAD MISSING
Deficiency Quantity	Parking Lot
Quantity Uom	500
Potential Action	S.F.
Urgency of Action	INSTALL NEW
Purpose of Action	PRIORITY 3
Deficiency Photo 2	LEVEL 2
Violations	No photo recorded
	No violations recorded
DRAINAGE SYSTEM FOR ASPHALT	Inspected
Catch Basins/Manhole - Surrounded by Asphalt	Inspected
Condition	2- Between Good and Fair
Deficiency	No deficiencies recorded
Culverts - Asphalt Covering	Does not exist
DRAINAGE SYSTEM FOR CONCRETE	Inspected
Catch Basins/Manhole - Surrounded by Concrete	Inspected
Condition	2- Between Good and Fair
Deficiency	No deficiencies recorded
Culverts - Concrete Covering	Does not exist
DRAINAGE SYSTEM FOR SOIL	Does not exist
DRINKING FOUNTAINS	Does not exist
FENCES	Inspected
Condition	3- Fair
Deficiency	CONCRETE CURB:DAMAGED/DETERIORATED
Deficiency Location/Instance	Parking Lot
Deficiency Quantity	20
Quantity Uom	S.F.
Potential Action	REPLACE
Urgency of Action	PRIORITY 3
Purpose of Action	LEVEL 2
Deficiency Photo 1	
Deficiency Photo 2	Parking Lot
Violations	No photo recorded
Deficiency	No violations recorded
Deficiency	WROUGHT IRON:DAMAGED/DETERIORATED
Deficiency Location/Instance	Along East Tremont Avenue

**NYC Department of Education
Building Condition Assessment Survey 2023-2024**

Architectural Inspection



X167

Question	Response
SITE	
FENCES	
Deficiency Quantity	160
Quantity Uom	S.F.
Potential Action	REPLACE
Urgency of Action	PRIORITY 3
Purpose of Action	LEVEL 2
Deficiency Photo 1	
	Along East Tremont Avenue
Deficiency Photo 2	No photo recorded
Violations	No violations recorded
Deficiency	CHAIN LINK:DAMAGED/DETERIORATED
Deficiency Location/Instance	Schoolyard
Deficiency Quantity	50
Quantity Uom	S.F.
Potential Action	REPLACE
Urgency of Action	PRIORITY 3
Purpose of Action	LEVEL 2
Deficiency Photo 1	
	Schoolyard
Deficiency Photo 2	No photo recorded
Violations	No violations recorded
IRRIGATION SYSTEM	Does not exist
PAVING	Inspected
Student Non-Use	Inspected
Gravel Exists?	No
Asphalt	Inspected
Condition	4- Between Fair and Poor
Deficiency	CRACKS - MAJOR
Deficiency Location/Instance	Parking Lot
Deficiency Quantity	800
Quantity Uom	S.F.
Potential Action	REPLACE
Urgency of Action	PRIORITY 3
Purpose of Action	LEVEL 2

**NYC Department of Education
Building Condition Assessment Survey 2023-2024**

Architectural Inspection

X167

Question	Response
SITE	
PAVING	
Student Non-Use	
Asphalt	
Deficiency Photo 1	
Deficiency Photo 2	Parking Lot
Violations	No photo recorded No violations recorded
Concrete	Inspected
Condition	2- Between Good and Fair
Deficiency	No deficiencies recorded
Pavers	Does not exist
Student Use	Inspected
Gravel Exists?	No
Asphalt	Inspected
Condition	4- Between Fair and Poor
Deficiency	CRACKS - MAJOR
Deficiency Location/Instance	Schoolyard
Deficiency Quantity	1,000
Quantity Uom	S.F.
Potential Action	REPLACE
Urgency of Action	PRIORITY 3
Purpose of Action	LEVEL 2
Deficiency Photo 1	
Deficiency Photo 2	Schoolyard
Violations	No photo recorded No violations recorded
Concrete	Inspected
Condition	3- Fair
Deficiency	CRACKS - MAJOR
Deficiency Location/Instance	Near Main Entrance
Deficiency Quantity	50
Quantity Uom	S.F.
Potential Action	REPLACE
Urgency of Action	PRIORITY 3
Purpose of Action	LEVEL 2

**NYC Department of Education
Building Condition Assessment Survey 2023-2024**

Architectural Inspection

X167

Question **Response**

SITE

PAVING

Student Use

Concrete

Deficiency Photo 1



Near Main Entrance

Deficiency Photo 2

No photo recorded

Violations

No violations recorded

Deficiency

HEAVING

Deficiency Location/Instance

Near Main Entrance

Deficiency Quantity

150

Quantity Uom

S.F.

Potential Action

REPLACE

Urgency of Action

PRIORITY 3

Purpose of Action

LEVEL 2

Deficiency Photo 1



Near Main Entrance

Deficiency Photo 2

No photo recorded

Violations

No violations recorded

Pavers

Does not exist

Site Sidewalks & Walkways

Inspected

Asphalt

Does not exist

Concrete

Inspected

Condition

3- Fair

Deficiency

CRACKS - MAJOR

Deficiency Location/Instance

Near Schoolyard

Deficiency Quantity

250

Quantity Uom

S.F.

Potential Action

REPLACE

Urgency of Action

PRIORITY 3

Purpose of Action

LEVEL 2

Deficiency Photo 1



Near Schoolyard



Deficiency Photo 2

No photo recorded

**NYC Department of Education
Building Condition Assessment Survey 2023-2024**

Architectural Inspection



X167

Question	Response
SITE	
PAVING	
Site Sidewalks & Walkways	
Concrete	
Violations	No violations recorded
Pavers	Does not exist
DOT Sidewalk	Inspected
Asphalt	Does not exist
Concrete	Inspected
Condition	4- Between Fair and Poor
Deficiency	DAMAGED/DETERIORATED/MISSING SECTIONS
Deficiency Location/Instance	Along East Tremont Avenue, West Farms Road
Deficiency Quantity	500
Quantity Uom	S.F.
Potential Action	REPLACE
Urgency of Action	PRIORITY 3
Purpose of Action	LEVEL 2
Deficiency Photo 1	
Deficiency Photo 2	Along West Farms Road
Violations	No photo recorded
Violations	No violations recorded
Deficiency	HEAVING
Deficiency Location/Instance	Along West Farms Road
Deficiency Quantity	200
Quantity Uom	S.F.
Potential Action	REPLACE
Urgency of Action	PRIORITY 3
Purpose of Action	LEVEL 2
Deficiency Photo 1	
Deficiency Photo 2	Along West Farms Road
Violations	No photo recorded
Violations	No violations recorded
Pavers	Does not exist
PLAYGROUNDS	Inspected
Instance on Schoolyard	Inspected
Benches	
Instance on Schoolyard	Does not exist
Fence	
Instance on Schoolyard	Inspected
Instance Condition	3- Fair
Deficiency	CHAIN LINK:DAMAGED/DETERIORATED

**NYC Department of Education
Building Condition Assessment Survey 2023-2024**

Architectural Inspection

X167

Question	Response
SITE	
PLAYGROUNDS	
Fence	
Deficiency Location/Instance	Near Entrance
Deficiency Quantity	50
Quantity Uom	S.F.
Potential Action	REPLACE
Urgency of Action	PRIORITY 3
Purpose of Action	LEVEL 2
Deficiency Photo 1	
Deficiency Photo 2	Near Entrance No photo recorded
Violations	No violations recorded
Pavement	
Instance on Schoolyard	Inspected
Instance Condition	3- Fair
Deficiency	ASPHALT:CRACKS - MAJOR
Deficiency Location/Instance	Near Entrance, Around Safety Surfacing
Deficiency Quantity	100
Quantity Uom	S.F.
Potential Action	REPLACE
Urgency of Action	PRIORITY 3
Purpose of Action	LEVEL 2
Deficiency Photo 1	
Deficiency Photo 2	Near Entrance No photo recorded
Violations	No violations recorded
Play Equipment	
Instance on Schoolyard	Inspected
Instance Condition	2- Between Good and Fair
Deficiency	No deficiencies recorded
Safety Surfacing	
Instance on Schoolyard	Inspected
Instance Condition	3- Fair
Deficiency	DETERIORATED/MISSING
Deficiency Location/Instance	Center
Deficiency Quantity	100
Quantity Uom	S.F.
Potential Action	REPLACE
Urgency of Action	PRIORITY 3
Purpose of Action	LEVEL 2

**NYC Department of Education
Building Condition Assessment Survey 2023-2024**

Architectural Inspection



X167

Question	Response
SITE	
PLAYGROUNDS	
Safety Surfacing	
Deficiency Photo 1	
	Center
Deficiency Photo 2	No photo recorded
Violations	No violations recorded
Unpaved Area	
Instance on Schoolyard	Does not exist
PLAYING SURFACE	Inspected
Playing Field	Inspected
Instance on Schoolyard	Inspected
Instance Condition	2- Between Good and Fair
Deficiency	No deficiencies recorded
Running Track	Does not exist
RETAINING WALLS	Inspected
Condition	2- Between Good and Fair
Are there any Retaining Walls 6' OR higher facing public street/sidewalk?	No
Deficiency	CAST IN PLACE CONCRETE:CRACKS/SPALLING - MAJOR
Deficiency Location/Instance	Near Main Entrance
Deficiency Quantity	10
Quantity Uom	S.F.
Potential Action	REPLACE
Urgency of Action	PRIORITY 3
Purpose of Action	LEVEL 2
Deficiency Photo 1	
	Near Main Entrance
Deficiency Photo 2	No photo recorded
Violations	No violations recorded
SEATING	Inspected
Benches	Inspected
Concrete	Does not exist
Metal/Wood/Plastic	Inspected
Condition	3- Fair
Deficiency	DAMAGED/DETERIORATED
Deficiency Location/Instance	Schoolyard
Deficiency Quantity	1
Quantity Uom	EACH
Potential Action	REPLACE
Urgency of Action	PRIORITY 3
Purpose of Action	LEVEL 2

**NYC Department of Education
Building Condition Assessment Survey 2023-2024**

Architectural Inspection

X167

Question	Response
SITE	
SEATING	
Benches	
Metal/Wood/Plastic	
Deficiency Photo 1	
Deficiency Photo 2	Schoolyard
Violations	No photo recorded No violations recorded
Bleachers	Does not exist
SITE WALLS (NOT RETAINING WALLS)	Inspected
Condition	2- Between Good and Fair
Deficiency	No deficiencies recorded
STAIRS/RAMPS: EXTERIOR	Inspected
Site Check/flank Walls	Inspected
Condition	2- Between Good and Fair
Deficiency	No deficiencies recorded
Railings	Inspected
Condition	2- Between Good and Fair
Deficiency	No deficiencies recorded
Stairs/ramps	Inspected
Condition	2- Between Good and Fair
Deficiency	CAST IN PLACE CONCRETE:CRACKS/SPALLING - MAJOR
Deficiency Location/Instance	Ramp Near Main Entrance
Deficiency Quantity	20
Quantity Uom	S.F.
Potential Action	REPLACE
Urgency of Action	PRIORITY 3
Purpose of Action	LEVEL 2
Deficiency Photo 1	
Deficiency Photo 2	Ramp Near Main Entrance
Violations	No photo recorded No violations recorded

NYC Department of Education
Building Condition Assessment Survey 2023-2024

Architectural Inspection

X167

Does the SCA expect asset to have artwork?

Yes

Accession No.

11637

Comments

No

Artwork exist at stated location?

Yes



Accession No.

30040

Comments

No

Artwork exist at stated location?

No

Accession No.

71440

Comments

No

Artwork exist at stated location?

No

Accession No.

71442

Comments

No

Artwork exist at stated location?

No

Accession No.

71446

Comments

No

Artwork exist at stated location?

No