

NYC Department of Education
Building Condition Assessment Survey 2023 - 2024

Architectural Inspection

Q223

Asset: P.S. 223 - QUEENS, 125-20 SUTPHIN BLVD, New York, 11436

Inspection Id	Inspection Type	Time In	Last Edited
SA : Q223	Architectural - Senior	2024-01-17 7:33 AM	2024-06-17 9:07 AM
AA : Q223	Architectural - Associate	2024-01-17 9:06 AM	2024-01-26 5:20 PM

Asset Data

Question	Answer
Was the building fully accessible for inspection	No
Inspection Access Comment	Catch basis/manhole surrounded by soil, student use paving, safety surfacing, playing field (snow cover)
Building Square Footage	102,000
Comments on the Area (for Athletic Field, Playing Surfaces, Leased Spaces)	None
Comments on the Stories (Floors) plus Basements	3+B
Comments on the Number of Classrooms	53
Comments on the Year Built	1974
Student Population	706
Staff Population	115
Weather	Fair
Principal(s) Information	
Principal Name	Tekesha Babb
Organization	P.S. 233 - Queens
Did you meet with this Principal?	Yes
Did this Principal provide feedback?	Yes
Summary of Principal's Feedback	The Principal's comments are as follows: 1. The 1st Floor Staff Toilet fixtures back up and need repairs. 2. The building HVAC system needs balancing.
Principal Name	James Thorbs
Organization	P75Q @ 223 (District 75) - Queens
Did you meet with this Principal?	No
Did this Principal provide feedback?	No
Custodian	Eric Guzman
Fireman	Franklin Duran
Facade Photo	



Sutphin Boulevard - Northwest view

NYC Department of Education
Building Condition Assessment Survey 2023 - 2024

Architectural Inspection

Q223

Main Entrance Photo



Facade A - Sutphin Boulevard

Roof Photo



Roof 1 - East view

Have any Systems/Major Building Components been upgraded?

Yes

Systems: Partial Coping repairs.

Year: 2023

Systems: 1st Floor Staff and Student toilet rooms upgraded to HC compliance

Year: 2020

Systems: Roof Barrier, Exterior Guards, Window Lintels, Windows - replacement; Exterior Walls, Roofing - repairs

Year: 2016

Systems: Coping - repairs

Year: 2011

Systems: Exterior Doors and Frames - repairs

Year: 2010

Systems: Staff and Student toilet room upgrades to HC compliance

Year: 2008

Systems: Roofing - replacement

Year: 1995

Have there been any Building Additions?

No

Tandem Schools?

No

Leased Space?

No

NYC Department of Education
Building Condition Assessment Survey 2023 - 2024

Architectural Inspection

Q223

Priority Condition

Priority Condition Exist Last Year?	Priority Category	Condition Description	Component Affected	Location Description	Person(s) Notified	Person(s) Title	PhotoImage
No condition recorded							

Structural Engineer Required

Structural Condition Type	Condition Description	Component Affected	Location Description	Person(s) Notified	Person(s) Title	PhotoImage
No condition recorded						

Programmatic Accessibility

Programmatic Accessibility Status Question	Response
Is the primary or secondary entrance on an accessible route?	Yes
Is the building a multi-story building?	Yes
Are all floors of the building accessible through compliant means?	Yes
Accessible classrooms exists on each floor?	Yes
Boys and Girls or Unisex accessible toilets exist on at least every other floor?	Yes
If the following spaces exist, are they ALL accessible? Art Room, Auditorium, Cafeteria, Computer, Gymnasiums, Library, Multipurpose Room, Science Labs	Yes

Physical Breakdown Structure	Exists	Required	Complies	Deficiency	Assistive Fire Listening System	Fire Alarm Strobe
------------------------------	--------	----------	----------	------------	---------------------------------	-------------------

PROGRAMMATIC ACCESSIBILITY						
Exterior Routes						
Exterior Entrances & Exits			Yes			
Exterior H/C Lifts	No	No				
Exterior Ramps and Railings	Yes		Yes			
Interior Routes						
Corridor and Lobby H/C Lifts	No	No				
Interior Corridor Doors and Hardware	Yes		Yes			
Interior Corridors and Lobbies			Yes			
Interior Elevators	Yes		Yes			
Interior Lobby Doors and Hardware			Yes			
Interior Ramps	Yes		Yes			
Rooms & Spaces						
Art Rooms	Room 206	Yes	Yes			
Auditorium	1st Floor	Yes	Yes		FM System	Yes
Cafeteria	1st Floor - Students, 1st Floor - Staff	Yes	Yes		FM System	Yes
Classrooms	1st-3rd Floor	Yes	Yes			
Computer Rooms		No				
Gymnasium	1st Floor	Yes	Yes		FM System	Yes
Library	Room 207	Yes	Yes			
Main Office	Room 101 (P.S. 223); Room 211 (P75Q @ 223 - District 75)	Yes	Yes			
Multi-purpose Room		No				
Nurse's Room	Rooms 103, 204	Yes	Yes			
Pool		No				

NYC Department of Education
Building Condition Assessment Survey 2023 - 2024

Architectural Inspection

Q223

Physical Breakdown Structure	Exists	Required	Complies	Deficiency	Assistive Listening System	Fire Alarm Strobe
Rooms & Spaces						
Science Lab	No					
Toilet Rooms (Boys)	Yes		Yes			
Toilet Rooms (Girls)	Yes		Yes			
Toilet Rooms (Staff)	Yes		Yes			

Building Template

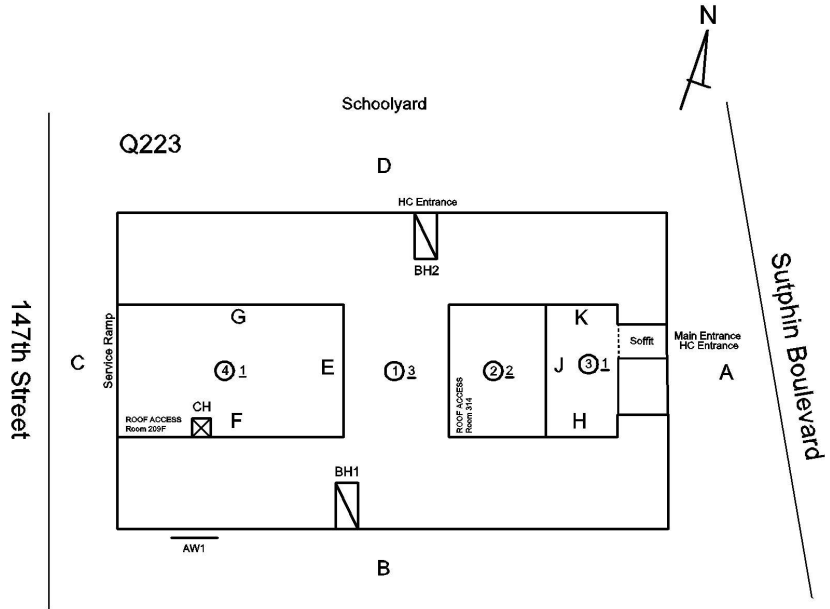

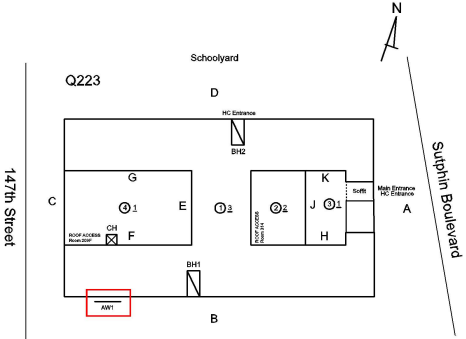

Inspection

Question	Response
Architectural	
EXTERIOR	Inspected
AREAWAY	Inspected
Instance on AW1	Inspected
Instance Condition	3 - Fair
Instance Quantity	1
Instance Quantity Uom	EACH
Deficiency	AREAWAY WALLS: CRACKS AND SPALLING
Roof Plan reference	
	
Deficiency Quantity	10
Quantity Uom	S.F.
Potential Action	REPLACE

**NYC Department of Education
Building Condition Assessment Survey 2023 - 2024**

Architectural Inspection

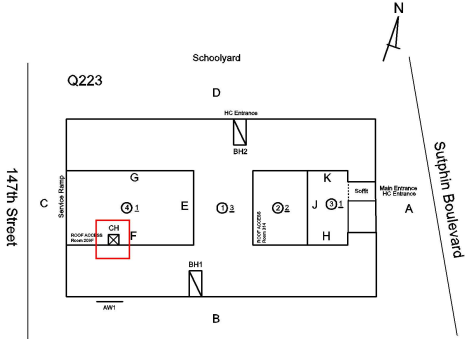
Q223

Question	Response
EXTERIOR	
AREAWAY	
Urgency of Action	PRIORITY 4
Purpose of Action	LEVEL 2
Deficiency Photo1	
Violations	Facade B - AW1 No violations recorded.
AWNINGS AND CANOPIES	
Condition	Inspected 2 - Between Good and Fair
Deficiency	No deficiencies recorded
CHIMNEY	
Material Type(s)	Inspected Masonry
Condition	2 - Between Good and Fair
Deficiency	BRICK: DETERIORATED CAP
Roof Plan reference	
Deficiency Quantity	10
Quantity Uom	L.F.
Potential Action	REPLACE
Urgency of Action	PRIORITY 3
Purpose of Action	LEVEL 2
Deficiency Photo1	
Violations	Roof 1 No violations recorded.
COPING	
Condition	Inspected 3 - Fair

NYC Department of Education
Building Condition Assessment Survey 2023 - 2024

Architectural Inspection

Q223

Question **Response**

EXTERIOR

COPING

Deficiency
 Roof Plan reference

CAST STONE: CRACKED/BROKEN PIECES

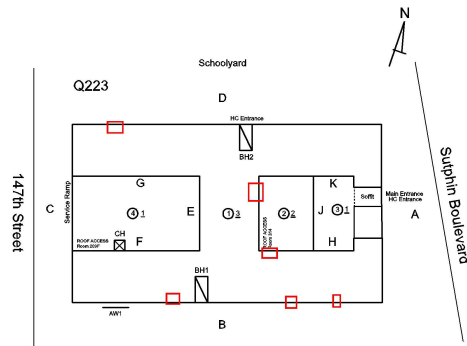

Deficiency Quantity
 Quantity Uom
 Potential Action
 Urgency of Action
 Purpose of Action
 Deficiency Photo1

30
 L.F.
 REPLACE-IN-KIND
 PRIORITY 4
 LEVEL 2



Roof 1
 No violations recorded.

Violations

CORNICE

Does not Exist

DOORS

Inspected

DOORS AND FRAMES

Inspected

Condition

4 - Between Fair and Poor

Deficiency

METAL CLAD: DETERIORATED DOOR AND FRAME - MAJOR DETERIORATION

Roof Plan reference

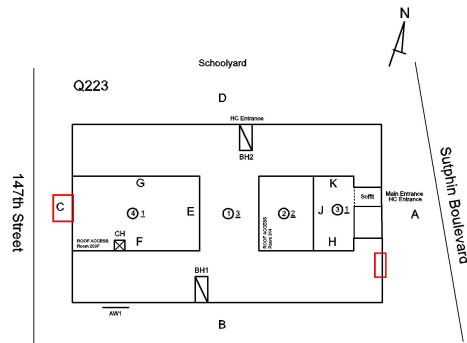

Deficiency Quantity
 Quantity Uom
 Potential Action
 Urgency of Action
 Purpose of Action

3
 EACH
 REPLACE
 PRIORITY 4
 LEVEL 2

**NYC Department of Education
Building Condition Assessment Survey 2023 - 2024**

Architectural Inspection

Q223

Question	Response
----------	----------

EXTERIOR

DOORS

DOORS AND FRAMES

Deficiency Photo1

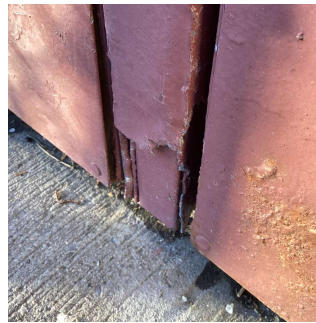

Facade A

Violations

No violations recorded.

DOOR HARDWARE

Inspected

Condition

3 - Fair

Deficiency

No deficiencies recorded

LINTELS

Inspected

Condition

2 - Between Good and Fair

Deficiency

No deficiencies recorded

TRANSOM/SIDE LIGHT

Inspected

Condition

4 - Between Fair and Poor

Deficiency

METAL: DENTED, MAJOR RUSTING

Roof Plan reference

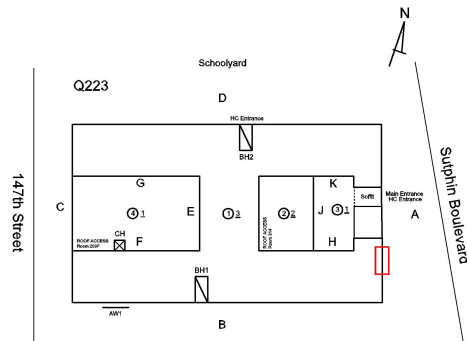

Deficiency Quantity

20

Quantity Uom

S.F.

Potential Action

REPLACE

Urgency of Action

PRIORITY 4

Purpose of Action

LEVEL 2

Deficiency Photo1



Facade A

Violations

No violations recorded.

EXTERIOR WALLS

Inspected

**NYC Department of Education
Building Condition Assessment Survey 2023 - 2024**

Architectural Inspection

Q223

Question	Response
----------	----------

EXTERIOR

EXTERIOR WALLS

Material Type(s)	Concrete, Masonry
Replacement Quantity	24,000
Replacement Uom	S.F.
Instance on All Facades	Inspected
Instance Condition	3 - Fair
Instance Quantity	24,000
Instance Quantity Uom	S.F.
Deficiency	BRICK: MINOR CRACKS AND SPALLING
Roof Plan reference	

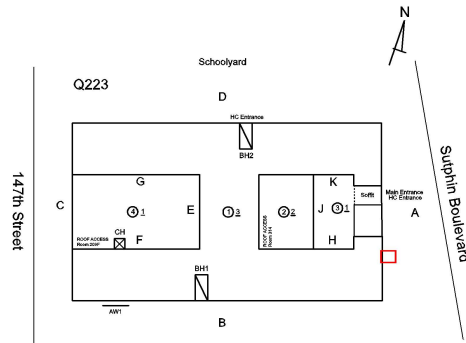

Elevation

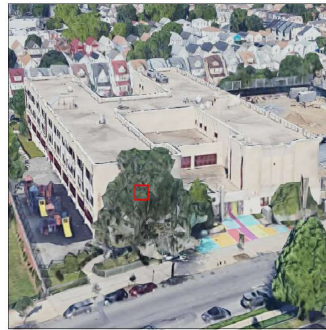

Deficiency Quantity	10
Quantity Uom	S.F.
Potential Action	RESTITCH
Urgency of Action	PRIORITY 3
Purpose of Action	LEVEL 2
Deficiency Photo1	



Facade A



Violations	No violations recorded.
------------	-------------------------

EXTERIOR SOFFITS	Inspected
Condition	2 - Between Good and Fair
Deficiency	No deficiencies recorded
LOADING DOCK	Does not Exist
LOUVER	Inspected

**NYC Department of Education
Building Condition Assessment Survey 2023 - 2024**

Architectural Inspection

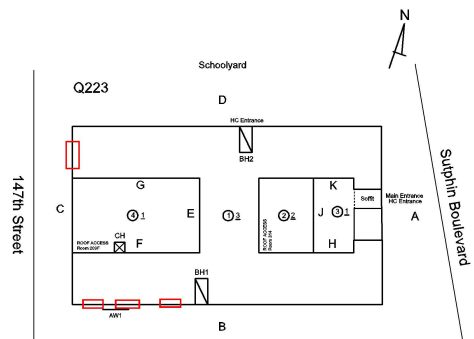
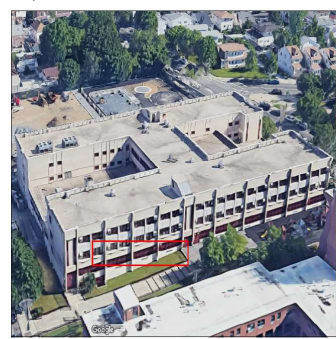
Q223

Question	Response
EXTERIOR	
LOUVER	
Condition	3 - Fair
Deficiency	BROKEN/ DENTED BLADES
Roof Plan reference	
Elevation	
Deficiency Quantity	30
Quantity Uom	S.F.
Potential Action	REPLACE
Urgency of Action	PRIORITY 4
Purpose of Action	LEVEL 2
Deficiency Photo1	
Violations	Facade B No violations recorded.
PARAPETS	
Material Type(s)	Inspected Masonry
Replacement Quantity	7,000
Replacement Uom	C.F.
Instance on All Facades	Inspected
Instance Condition	3 - Fair
Instance Quantity	7,000
Instance Quantity Uom	C.F.
Deficiency	BRICK: MAJOR DETERIORATION/CRACKS

**NYC Department of Education
Building Condition Assessment Survey 2023 - 2024**

Architectural Inspection

Q223

Question

Response

EXTERIOR

PARAPETS

Roof Plan reference

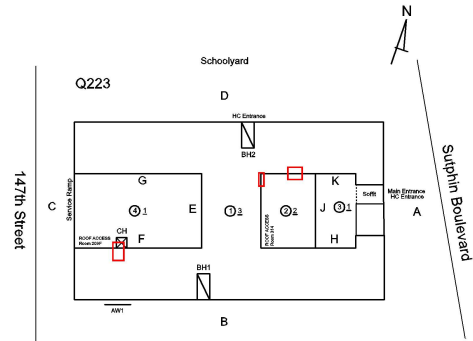

Deficiency Quantity

30

Quantity Uom

S.F.

Potential Action

REMOVE AND REBUILD

Urgency of Action

PRIORITY 4

Purpose of Action

LEVEL 2

Deficiency Photo1



Roof 1

Violations

No violations recorded.

Deficiency

BRICK: MINOR CRACKS, SPALLING

Roof Plan reference

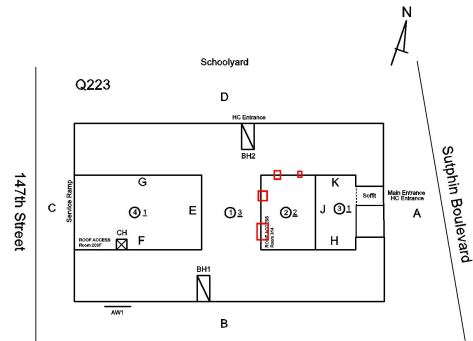

Deficiency Quantity

40

Quantity Uom

S.F.

Potential Action

REPAIR

Urgency of Action

PRIORITY 3

Purpose of Action

LEVEL 2

NYC Department of Education
Building Condition Assessment Survey 2023 - 2024

Architectural Inspection

Q223

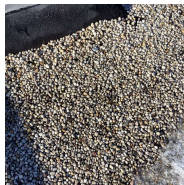
Question	Response
EXTERIOR	
PARAPETS	
Deficiency Photo1	
Violations	Roof 1 No violations recorded.
PLAZA DECK	Does not Exist
ROOF	Inspected
Roofing	Inspected
Replacement Quantity	42,000
Replacement Uom	S.F.
ROOF HATCH/SMOKE HATCH	Does not Exist
LEADERS, GUTTERS, DOWNSPOUTS, SCUPPERS	Inspected
Condition	2 - Between Good and Fair
Deficiency	No deficiencies recorded
ROOF BARRIER/FENCE	Inspected
Condition	2 - Between Good and Fair
Deficiency	No deficiencies recorded
ROOF CAGE	Does not Exist
ROOFING	Inspected
Instance on Built-Up: All Roofs	Inspected
Instance Condition	3 - Fair
Instance Photo	
	Roof 1
Instance Quantity	42,000
Instance Quantity Uom	S.F.
Does the roof have major mechanical equipment sitting on Dunnage Steel less than 18" above the Roofing?	Yes
Does this roof instance have a Sustainable Roof System?	No
Do solar panels exist on these roofs?	No
Is/Are the roof(s) suitable for Solar Panel installation?	Yes
Installation Year	1995
Source of Installation	Custodial Staff
Deficiency	No deficiencies recorded
ROOFING DRAINS	Inspected
Condition	2 - Between Good and Fair
Deficiency	No deficiencies recorded
Specialties	Inspected

**NYC Department of Education
Building Condition Assessment Survey 2023 - 2024**

Architectural Inspection

Q223

Question	Response
----------	----------

EXTERIOR

ROOF

Specialties

BULKHEAD/PENTHOUSE

Inspected

Condition

3 - Fair

Deficiency

BULKHEAD/PENTHOUSE WALLS/EXTERIOR: DETERIORATED JOINTS

Roof Plan reference

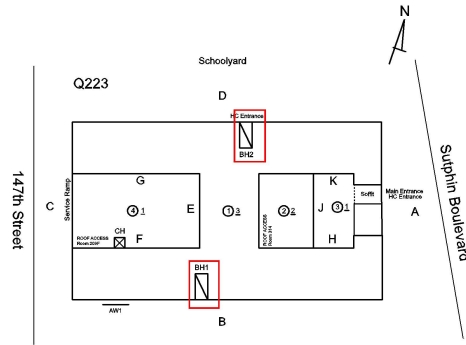

Deficiency Quantity

100

Quantity Uom

S.F.

Potential Action

REPOINT

Urgency of Action

PRIORITY 3

Purpose of Action

LEVEL 2

Deficiency Photo1

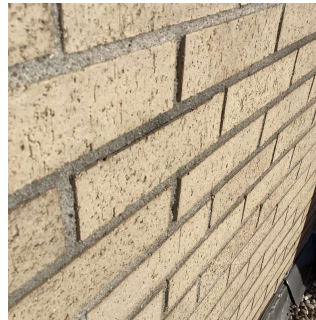

Roof 1 - Bulkhead 2

Violations

No violations recorded.

CUPOLA/ SPIRES/ TOWERS

Does not Exist

DORMER

Does not Exist

DUNNAGE STEEL

Inspected

Condition

3 - Fair

Deficiency

HEIGHT LESS THAN 18"

Roof Plan reference

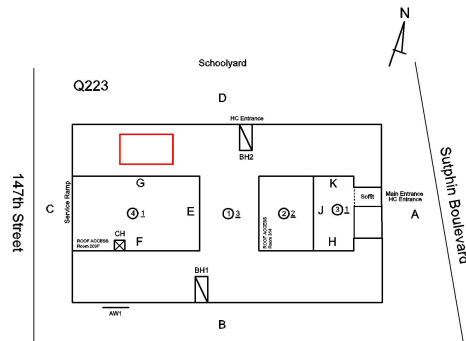

Deficiency Quantity

50

Quantity Uom

L.F.

Potential Action

REPLACE

**NYC Department of Education
Building Condition Assessment Survey 2023 - 2024**

Architectural Inspection

Q223

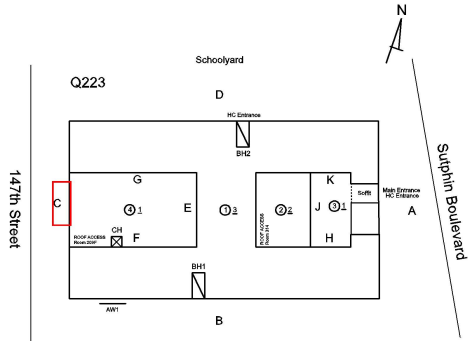
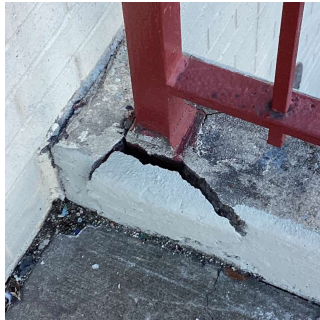
Question	Response
EXTERIOR	
ROOF	
Specialties	
DUNNAGE STEEL	
Urgency of Action	PRIORITY 3
Purpose of Action	LEVEL 2
Deficiency Photo1	
	Roof 1
Violations	No violations recorded.
SKYLIGHT/ROOF VENT	Does not Exist
ROOF/GRAVITY TANK	Does not Exist
STAIRS/RAMPS: EXTERIOR	Inspected
BUILDING CHEEK/FLANK WALLS	Inspected
Condition	3 - Fair
Deficiency	CAST IN PLACE CONCRETE: CRACKS/SPALLING - MAJOR
Roof Plan reference	
Deficiency Quantity	10
Quantity Uom	S.F.
Potential Action	REPLACE
Urgency of Action	PRIORITY 4
Purpose of Action	LEVEL 2
Deficiency Photo1	
	Facade C
Violations	No violations recorded.
RAILINGS	Inspected

**NYC Department of Education
Building Condition Assessment Survey 2023 - 2024**

Architectural Inspection

Q223

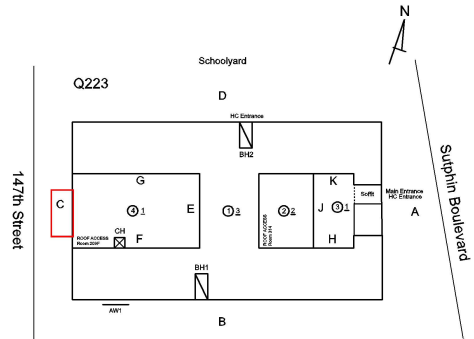
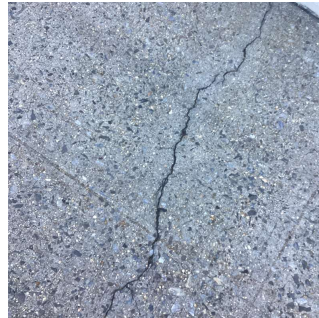
Question	Response
EXTERIOR	
STAIRS/RAMPS: EXTERIOR	
RAILINGS	Inspected
Condition	2 - Between Good and Fair
Deficiency	No deficiencies recorded
STAIRS/RAMPS	Inspected
Condition	3 - Fair
Deficiency	CONCRETE: CRACKS/SPALLING - MINOR
Roof Plan reference	
Deficiency Quantity	20
Quantity Uom	S.F.
Potential Action	REPAIR
Urgency of Action	PRIORITY 3
Purpose of Action	LEVEL 2
Deficiency Photo1	
Violations	Facade C No violations recorded.
WINDOWS	Inspected
Replacement Quantity	8,000
Replacement Uom	S.F.
EXTERIOR GUARDS	Inspected
Condition	2 - Between Good and Fair
Deficiency	No deficiencies recorded
LINTELS	Inspected
Condition	2 - Between Good and Fair
Deficiency	No deficiencies recorded
WINDOWS	Inspected
Material Type(s)	Aluminum
Instance on Aluminum - Double Hung: All Facades except Facade J	Inspected
Instance Condition	1 - Good
Instance Quantity	7,600
Instance Quantity Uom	S.F.
Are these windows insulated	Yes

NYC Department of Education
Building Condition Assessment Survey 2023 - 2024

Architectural Inspection

Q223

Question	Response
EXTERIOR	
WINDOWS	
WINDOWS	
Installation Year	2016
Source of Installation	Custodial Staff
Deficiency	No deficiencies recorded
Instance on Aluminum - Other: Facades B, J	Inspected
Instance Condition	1 - Good
Instance Quantity	400
Instance Quantity Uom	S.F.
Are these windows insulated	No
Installation Year	2016
Source of Installation	Custodial Staff
Deficiency	No deficiencies recorded
INTERIOR	Inspected
POOLS	Does not Exist
STRUCTURAL	Inspected
COLUMNS/BEAMS/BEARING WALLS	Inspected
Condition	2 - Between Good and Fair
Deficiency	No deficiencies recorded
FLOOR STRUCTURE	Inspected
Condition	2 - Between Good and Fair
Deficiency	No deficiencies recorded
FOUNDATION WALLS	Inspected
Material Type(s)	Concrete
Condition	2 - Between Good and Fair
Deficiency	No deficiencies recorded
ROOF STRUCTURE	Inspected
Condition	2 - Between Good and Fair
Deficiency	No deficiencies recorded
VAULTS-BUNKERS	Does not Exist
AUDITORIUM	Inspected
Instance on 1st Floor (225 Seats)	Inspected
Ceiling	
Instance on 1st Floor (225 Seats)	Inspected
Condition	2 - Between Good and Fair
Deficiency	No deficiencies recorded
Door(s)	
Instance on 1st Floor (225 Seats)	Inspected
Condition	2 - Between Good and Fair
Deficiency	No deficiencies recorded
Fixed H/C Lift	
Instance on 1st Floor (225 Seats)	Does not Exist
Fixed Seating	
Instance on 1st Floor (225 Seats)	Inspected
Condition	2 - Between Good and Fair
Deficiency	No deficiencies recorded
Floor Finish	
Instance on 1st Floor (225 Seats)	Inspected
Condition	2 - Between Good and Fair

NYC Department of Education
Building Condition Assessment Survey 2023 - 2024

Architectural Inspection

Q223

Question	Response
INTERIOR	
AUDITORIUM	
Floor Finish	
Deficiency	No deficiencies recorded
Sliding-folding Partition	
Instance on 1st Floor (225 Seats)	Inspected
Condition	5 - Poor
Deficiency	MOTOR: INOPERABLE
Deficiency Location/Instance	Rear
Deficiency Quantity	1
Quantity Uom	EACH
Potential Action	REPLACE
Urgency of Action	PRIORITY 3
Purpose of Action	LEVEL 2
Deficiency Photo1	No photo recorded
Violations	No violations recorded.
Stage	
Instance on 1st Floor (225 Seats)	Inspected
Stage	Inspected
Instance on 1st Floor (225 Seats)	Inspected
Condition	2 - Between Good and Fair
Deficiency	DAMAGED FLOOR
Deficiency Location/Instance	Right Side
Deficiency Quantity	10
Quantity Uom	S.F.
Potential Action	REPLACE
Urgency of Action	PRIORITY 3
Purpose of Action	LEVEL 2
Deficiency Photo1	
Violations	Right Side No violations recorded.
Stage Curtain Rigging	
Instance on 1st Floor (225 Seats)	Inspected
Condition	2 - Between Good and Fair
Deficiency	No deficiencies recorded
Stage Curtains	
Instance on 1st Floor (225 Seats)	Inspected
Condition	3 - Fair
Deficiency	WORN/DETERIORATED
Deficiency Location/Instance	Right Side Main Curtain
Deficiency Quantity	100
Quantity Uom	S.F.

**NYC Department of Education
Building Condition Assessment Survey 2023 - 2024**

Architectural Inspection

Q223

Question	Response
INTERIOR	
AUDITORIUM	
Stage	
Stage Curtains	
Potential Action	REPLACE
Urgency of Action	PRIORITY 3
Purpose of Action	LEVEL 2
Deficiency Photo1	
	Right Side Main Curtain
Violations	No violations recorded.
Walls	
Instance on 1st Floor (225 Seats)	Inspected
Condition	2 - Between Good and Fair
Deficiency	WOOD PANELING: DETERIORATED
Deficiency Location/Instance	Right Side
Deficiency Quantity	10
Quantity Uom	S.F.
Potential Action	REPLACE
Urgency of Action	PRIORITY 3
Purpose of Action	LEVEL 2
Deficiency Photo1	
	Right Side
Violations	No violations recorded.
Window Curtains/Shades/Blinds	
Instance on 1st Floor (225 Seats)	Does not Exist
CAFETERIA	
Instance on 1st Floor - Staff (750 SF)	Inspected
Instance on 1st Floor - Students	Inspected
Ceiling	
Instance on 1st Floor - Staff (750 SF)	Inspected
Condition	2 - Between Good and Fair
Deficiency	PLASTER: CRACKS/SPALLING
Deficiency Location/Instance	Near Entrance from Corridor
Deficiency Quantity	10

NYC Department of Education
Building Condition Assessment Survey 2023 - 2024

Architectural Inspection



Q223

Question	Response
INTERIOR	
CAFETERIA	
Ceiling	
Quantity Uom	S.F.
Potential Action	REPLACE
Urgency of Action	PRIORITY 3
Purpose of Action	LEVEL 2
Deficiency Photo1	
Violations	Near Entrance from Corridor No violations recorded.
Door(s)	
Instance on 1st Floor - Staff (750 SF)	Inspected
Condition	3 - Fair
Deficiency	WOOD: DETERIORATED DOOR
Deficiency Location/Instance	Entrance from Corridor
Deficiency Quantity	1
Quantity Uom	EACH
Potential Action	MAINTENANCE
Urgency of Action	PRIORITY 3
Purpose of Action	LEVEL 2
Deficiency Photo1	
Violations	Entrance from Corridor No violations recorded.
Fixed Equipment	
Instance on 1st Floor - Staff (750 SF)	Does not Exist
Instance on 1st Floor - Students	Does not Exist
Floor Finish	
Instance on 1st Floor - Students	Inspected
Condition	2 - Between Good and Fair
Deficiency	VINYL TILES: BROKEN/DETERIORATED/MISSING TILES
Deficiency Location/Instance	Near Kitchen
Deficiency Quantity	10
Quantity Uom	S.F.
Potential Action	REPLACE

NYC Department of Education
Building Condition Assessment Survey 2023 - 2024

Architectural Inspection

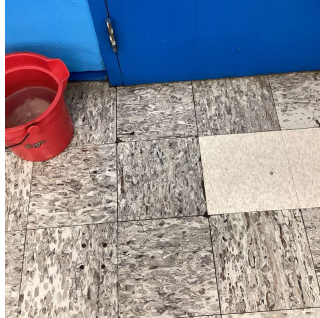
Q223

Question	Response
INTERIOR	
CAFETERIA	
Floor Finish	
Urgency of Action	PRIORITY 3
Purpose of Action	LEVEL 2
Deficiency Photo1	
	Near Kitchen
Violations	No violations recorded.
Instance on 1st Floor - Staff (750 SF)	Inspected
Condition	2 - Between Good and Fair
Deficiency	VINYL TILES: BROKEN/DETERIORATED/MISSING TILES
Deficiency Location/Instance	Near Drinking Fountain, Near Windows
Deficiency Quantity	15
Quantity Uom	S.F.
Potential Action	REPLACE
Urgency of Action	PRIORITY 3
Purpose of Action	LEVEL 2
Deficiency Photo1	
	Near Drinking Fountain
Violations	No violations recorded.
Sliding-folding Partition	
Instance on 1st Floor - Students	Not Required
Instance on 1st Floor - Staff (750 SF)	Does not Exist
Stage	
Instance on 1st Floor - Students	Does not Exist
Instance on 1st Floor - Staff (750 SF)	Does not Exist
Walls	
Instance on 1st Floor - Students	Inspected
Condition	2 - Between Good and Fair
Deficiency	MASONRY: CRACKS/SPALLING
Deficiency Location/Instance	Storage Room
Deficiency Quantity	10
Quantity Uom	S.F.
Potential Action	REPLACE

**NYC Department of Education
Building Condition Assessment Survey 2023 - 2024**

Architectural Inspection

Q223

Question	Response
-----------------	-----------------

INTERIOR

CAFETERIA

Walls

Urgency of Action
Purpose of Action
Deficiency Photo1

PRIORITY 3
LEVEL 2



Storage Room

Violations

No violations recorded.

Deficiency
Deficiency Location/Instance
Deficiency Quantity
Quantity Uom
Potential Action
Urgency of Action
Purpose of Action
Deficiency Photo1

WOOD PANELING: DETERIORATED
Near Drinking Fountain, Near Kitchen
20
S.F.
REPLACE
PRIORITY 3
LEVEL 2

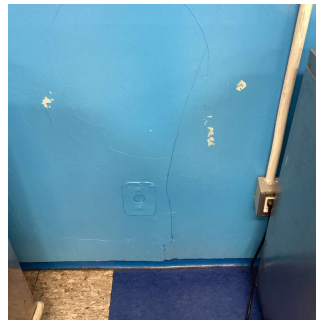

Near Kitchen

Violations

No violations recorded.

Deficiency
Deficiency Location/Instance
Deficiency Quantity
Quantity Uom
Potential Action
Urgency of Action
Purpose of Action
Deficiency Photo1



CERAMIC TILE: BROKEN/ MISSING
Columns at Center
10
S.F.
REPLACE
PRIORITY 3
LEVEL 2



NYC Department of Education
Building Condition Assessment Survey 2023 - 2024

Architectural Inspection



Q223

Question	Response
INTERIOR	
CAFETERIA	
Walls	
Violations	Columns at Center No violations recorded.
Instance on 1st Floor - Staff (750 SF)	Inspected
Condition	2 - Between Good and Fair
Deficiency	PLASTER: CRACKS/SPALLING
Deficiency Location/Instance	Near Entrance from Kitchen, Near Windows
Deficiency Quantity	20
Quantity Uom	S.F.
Potential Action	REPLACE
Urgency of Action	PRIORITY 3
Purpose of Action	LEVEL 2
Deficiency Photo1	
Violations	Near Entrance from Kitchen No violations recorded.
Window Curtains/Shades/Blinds	
Instance on 1st Floor - Students	Does not Exist
Instance on 1st Floor - Staff (750 SF)	Does not Exist
CLASSROOMS/CORRIDORS/ADMIN SPACES	
Condition	Inspected
Ceiling	
Condition	Inspected
Condition	2 - Between Good and Fair
Deficiency	PLASTER: CRACKS/SPALLING
Deficiency Location/Instance	Corridor near Rooms 203D, 203E, 300H
Deficiency Quantity	30
Quantity Uom	S.F.
Potential Action	REPLACE
Urgency of Action	PRIORITY 3
Purpose of Action	LEVEL 2
Deficiency Photo1	
Violations	Corridor near Room 300H No violations recorded.

NYC Department of Education
Building Condition Assessment Survey 2023 - 2024

Architectural Inspection

Q223

Question	Response
INTERIOR	
CLASSROOMS/CORRIDORS/ADMIN SPACES	
Ceiling	
Deficiency	ACOUSTIC TILES ON PLASTER: DAMAGED/MISSING
Deficiency Location/Instance	Corridor near Rooms 115, 130, 207, 312, 318, and others
Deficiency Quantity	180
Quantity Uom	S.F.
Potential Action	REPLACE
Urgency of Action	PRIORITY 3
Purpose of Action	LEVEL 2
Deficiency Photo1	
Violations	Corridor near Room 115 No violations recorded.
Door(s)	Inspected
Condition	5 - Poor
Deficiency	WOOD: DETERIORATED DOOR
Deficiency Location/Instance	Rooms 115, 123, 300A, 300D, 304, 313A
Deficiency Quantity	6
Quantity Uom	EACH
Potential Action	MAINTENANCE
Urgency of Action	PRIORITY 3
Purpose of Action	LEVEL 2
Deficiency Photo1	
Violations	Room 300D No violations recorded.
Deficiency	METAL: DETERIORATED DOOR
Deficiency Location/Instance	Rooms 203, 300
Deficiency Quantity	2
Quantity Uom	EACH
Potential Action	MAINTENANCE
Urgency of Action	PRIORITY 3
Purpose of Action	LEVEL 2

**NYC Department of Education
Building Condition Assessment Survey 2023 - 2024**

Architectural Inspection

Q223

Question	Response
INTERIOR	
CLASSROOMS/CORRIDORS/ADMIN SPACES	
Door(s)	
Deficiency Photo1	
Violations	Room 300 No violations recorded.
Floor Finish	Inspected
Condition	2 - Between Good and Fair
Deficiency	VINYL TILES: BROKEN/DETERIORATED/MISSING TILES
Deficiency Location/Instance	Rooms 114, 200, 300D, 305, 309, and others
Deficiency Quantity	140
Quantity Uom	S.F.
Potential Action	REPLACE
Urgency of Action	PRIORITY 3
Purpose of Action	LEVEL 2
Deficiency Photo1	
Violations	Room 300D No violations recorded.
Deficiency	VINYL TILES: DETERIORATED SUBSTRATE
Deficiency Location/Instance	Corridor near Stairs A/2, C/3, F/3, Corridor near Rooms 103, 218, and others
Deficiency Quantity	70
Quantity Uom	S.F.
Potential Action	REPLACE
Urgency of Action	PRIORITY 3
Purpose of Action	LEVEL 2

NYC Department of Education
Building Condition Assessment Survey 2023 - 2024

Architectural Inspection



Q223

Question	Response
INTERIOR	
CLASSROOMS/CORRIDORS/ADMIN SPACES	
Floor Finish	Inspected
Deficiency Photo1	
Violations	Corridor near Stair C/3 No violations recorded.
Walls	Inspected
Condition	2 - Between Good and Fair
Deficiency	GLAZED BLOCK: CRACKS/SPALLING
Deficiency Location/Instance	Corridor near Stairs D/1, E/2
Deficiency Quantity	20
Quantity Uom	S.F.
Potential Action	REPLACE
Urgency of Action	PRIORITY 3
Purpose of Action	LEVEL 2
Deficiency Photo1	
Violations	Corridor near Stair E/2 No violations recorded.
Specialties	Does not Exist
GYMNASIUM	Inspected
Instance on 1st Floor	Inspected
Ceiling	
Instance on 1st Floor	Inspected
Condition	2 - Between Good and Fair
Deficiency	No deficiencies recorded
Door(s)	
Instance on 1st Floor	Inspected
Condition	2 - Between Good and Fair
Deficiency	No deficiencies recorded
Fixed Equipment	
Instance on 1st Floor	Inspected
Condition	2 - Between Good and Fair
Deficiency	No deficiencies recorded
Floor Finish	

NYC Department of Education
Building Condition Assessment Survey 2023 - 2024

Architectural Inspection

Q223

Question	Response
INTERIOR	
GYMNASIUM	
Floor Finish	
Instance on 1st Floor	Inspected
Condition	2 - Between Good and Fair
Deficiency	VINYL TILES: BROKEN/DETERIORATED/MISSING TILES
Deficiency Location/Instance	Near Drinking Fountain, Left Side
Deficiency Quantity	20
Quantity Uom	S.F.
Potential Action	REPLACE
Urgency of Action	PRIORITY 3
Purpose of Action	LEVEL 2
Deficiency Photo1	
Violations	Near Drinking Fountain No violations recorded.
Seating	
Instance on 1st Floor	Does not Exist
Sliding-folding Partition	
Instance on 1st Floor	Does not Exist
Stage	
Instance on 1st Floor	Does not Exist
Walls	
Instance on 1st Floor	Inspected
Condition	2 - Between Good and Fair
Deficiency	GLAZED BLOCK: CRACKS/SPALLING
Deficiency Location/Instance	Right Side
Deficiency Quantity	10
Quantity Uom	S.F.
Potential Action	REPLACE
Urgency of Action	PRIORITY 3
Purpose of Action	LEVEL 2
Deficiency Photo1	
Violations	Right Side No violations recorded.

**NYC Department of Education
Building Condition Assessment Survey 2023 - 2024**

Architectural Inspection

Q223

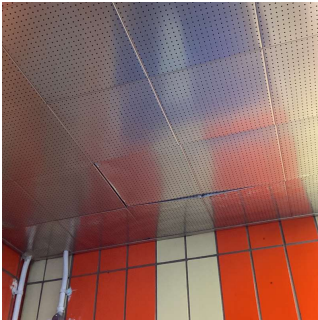
Question	Response
INTERIOR	
GYMNASIUM	Inspected
Window Curtains/Shades/Blinds	
Instance on 1st Floor	Does not Exist
INTERIOR DOOR HARDWARE	Inspected
Condition	3 - Fair
Deficiency	No deficiencies recorded
INTERIOR GUARDS	Inspected
Condition	2 - Between Good and Fair
Deficiency	No deficiencies recorded
KITCHEN	Inspected
Instance on 1st Floor	Inspected
Ceiling	
Instance on 1st Floor	Inspected
Condition	2 - Between Good and Fair
Deficiency	METAL PAN: DAMAGED/MISSING
Deficiency Location/Instance	Near Walk-in Cooler, Near Entrance from Student Cafeteria
Deficiency Quantity	20
Quantity Uom	S.F.
Potential Action	REPLACE
Urgency of Action	PRIORITY 3
Purpose of Action	LEVEL 2
Deficiency Photo1	
Violations	Near Entrance from Student Cafeteria No violations recorded.
Door(s)	
Instance on 1st Floor	Inspected
Condition	3 - Fair
Deficiency	WOOD: DETERIORATED DOOR
Deficiency Location/Instance	Exit 7 Vestibule
Deficiency Quantity	1
Quantity Uom	EACH
Potential Action	MAINTENANCE
Urgency of Action	PRIORITY 3
Purpose of Action	LEVEL 2

**NYC Department of Education
Building Condition Assessment Survey 2023 - 2024**

Architectural Inspection

Q223

Question	Response
----------	----------

INTERIOR

KITCHEN

Door(s)

Deficiency Photo1



Exit 7 Vestibule

Violations

No violations recorded.

Floor Finish

Instance on 1st Floor	Inspected
-----------------------	-----------

Condition	3 - Fair
-----------	----------

Deficiency TERRAZZO: CRACKS

Deficiency Location/Instance Exit 7 Vestibule

Deficiency Quantity 10

Quantity Uom S.F.

Potential Action REPLACE

Urgency of Action PRIORITY 3

Purpose of Action LEVEL 2

Deficiency Photo1



Exit 7 Vestibule

Violations

No violations recorded.

Deficiency VINYL TILES: BROKEN/DETERIORATED/MISSING TILES

Deficiency Location/Instance Office

Deficiency Quantity 10

Quantity Uom S.F.

Potential Action REPLACE

Urgency of Action PRIORITY 3

Purpose of Action LEVEL 2

NYC Department of Education
Building Condition Assessment Survey 2023 - 2024

Architectural Inspection

Q223

Question

Response

INTERIOR

KITCHEN

Floor Finish

Deficiency Photo1



Office

Violations

No violations recorded.

Deficiency

CONCRETE: CRACKS

Deficiency Location/Instance

Storage Room

Deficiency Quantity

15

Quantity Uom

S.F.

Potential Action

REPLACE

Urgency of Action

PRIORITY 3

Purpose of Action

LEVEL 2

Deficiency Photo1



Storage Room

Violations

No violations recorded.

Deficiency

QUARRY TILE: BROKEN/MISSING TILES

Deficiency Location/Instance

Near Staff Servery, Near Windows

Deficiency Quantity

20

Quantity Uom

S.F.

Potential Action

REPLACE

Urgency of Action

PRIORITY 3

Purpose of Action

LEVEL 2

Deficiency Photo1

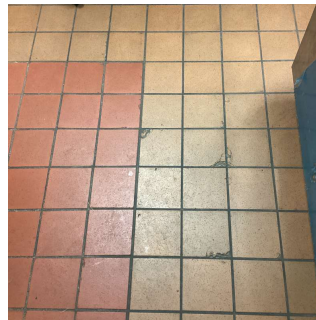

Near Staff Servery



Violations

No violations recorded.

NYC Department of Education
Building Condition Assessment Survey 2023 - 2024

Architectural Inspection

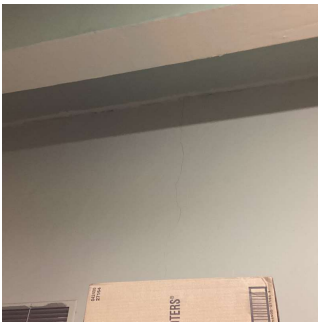
Q223

Question	Response
INTERIOR	
KITCHEN	
Walls	
Instance on 1st Floor	Inspected
Condition	2 - Between Good and Fair
Deficiency	PLASTER: CRACKS/SPALLING
Deficiency Location/Instance	Storage Room
Deficiency Quantity	10
Quantity Uom	S.F.
Potential Action	REPLACE
Urgency of Action	PRIORITY 3
Purpose of Action	LEVEL 2
Deficiency Photo1	
Violations	Storage Room No violations recorded.
LIBRARY	
Instance on Room 207	Inspected
Condition	2 - Between Good and Fair
Deficiency	SINK/STORAGE CABINET - DAMAGED/DETERIORATED
Deficiency Location/Instance	Near Entrance
Deficiency Quantity	10
Quantity Uom	L.F.
Potential Action	REPLACE
Urgency of Action	PRIORITY 3
Purpose of Action	LEVEL 2
Deficiency Photo1	
Violations	Near Entrance No violations recorded.
Ceiling	
Instance on Room 207	Inspected
Condition	2 - Between Good and Fair
Deficiency	No deficiencies recorded

NYC Department of Education
Building Condition Assessment Survey 2023 - 2024

Architectural Inspection

Q223

Question	Response
INTERIOR	
LIBRARY	
Door(s)	
Instance on Room 207	Inspected
Condition	2 - Between Good and Fair
Deficiency	No deficiencies recorded
Floor Finish	
Instance on Room 207	Inspected
Condition	2 - Between Good and Fair
Deficiency	VINYL TILES: BROKEN/DETERIORATED/MISSING TILES
Deficiency Location/Instance	Near Windows
Deficiency Quantity	10
Quantity Uom	S.F.
Potential Action	REPLACE
Urgency of Action	PRIORITY 3
Purpose of Action	LEVEL 2
Deficiency Photo1	
	Near Windows
Violations	No violations recorded.
Walls	
Instance on Room 207	Inspected
Condition	2 - Between Good and Fair
Deficiency	No deficiencies recorded
LOCKER ROOM	Does not Exist
MULTI-PURPOSE ROOM	Does not Exist
SCIENCE DEMO ROOM	Does not Exist
SCIENCE LAB	Does not Exist
SCIENCE PREP ROOM	Does not Exist
SHOWER ROOM	Does not Exist
STAIRS/RAMPS: INTERIOR	Inspected
Do Letter Stair Signs Exist?	Yes
Ceiling	
Condition	2 - Between Good and Fair
Deficiency	PLASTER: CRACKS/SPALLING
Deficiency Location/Instance	Stair D/1 Vestibule
Deficiency Quantity	10
Quantity Uom	S.F.
Potential Action	REPLACE
Urgency of Action	PRIORITY 3
Purpose of Action	LEVEL 2

**NYC Department of Education
Building Condition Assessment Survey 2023 - 2024**

Architectural Inspection

Q223

Question	Response
INTERIOR	
STAIRS/RAMPS: INTERIOR	
Ceiling	
Deficiency Photo1	
Violations	Stair D/1 Vestibule No violations recorded.
Door(s)	Inspected
Condition	2 - Between Good and Fair
Deficiency	No deficiencies recorded
Partition	Does not Exist
Railings	Inspected
Condition	2 - Between Good and Fair
Deficiency	No deficiencies recorded
Stairs and Landings	Inspected
Condition	3 - Fair
Deficiency	TERRAZZO: CRACKS
Deficiency Location/Instance	Stairs B/1 Vestibule, C/1 Vestibule, E/1 Vestibule
Deficiency Quantity	30
Quantity Uom	S.F.
Potential Action	REPLACE
Urgency of Action	PRIORITY 3
Purpose of Action	LEVEL 2
Deficiency Photo1	
Violations	Stair B/1 Vestibule No violations recorded.
Deficiency	STONE: BROKEN/MISSING
Deficiency Location/Instance	Stair A/1
Deficiency Quantity	10
Quantity Uom	S.F.
Potential Action	REPLACE
Urgency of Action	PRIORITY 3
Purpose of Action	LEVEL 2

**NYC Department of Education
Building Condition Assessment Survey 2023 - 2024**

Architectural Inspection

Q223

Question

Response

INTERIOR

STAIRS/RAMPS: INTERIOR

Stairs and Landings

Deficiency Photo1



Stair A/1

Violations

No violations recorded.

Deficiency

VINYL TILES: DETERIORATED SUBSTRATE

Deficiency Location/Instance

Stairs A/3, E/3, F/1,2

Deficiency Quantity

40

Quantity Uom

S.F.

Potential Action

REPLACE

Urgency of Action

PRIORITY 3

Purpose of Action

LEVEL 2

Deficiency Photo1

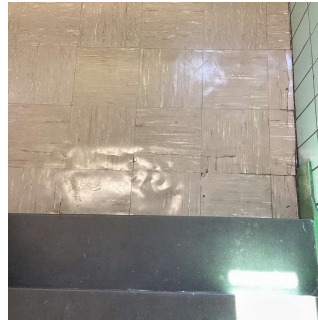

Stair E/3

Violations

No violations recorded.

Deficiency

VINYL TILES: BROKEN/DETERIORATED/MISSING TILES

Deficiency Location/Instance

Stair B/1,2,3,Bulkhead, F/1, and others

Deficiency Quantity

80

Quantity Uom

S.F.

Potential Action

REPLACE

Urgency of Action

PRIORITY 3

Purpose of Action

LEVEL 2

Deficiency Photo1

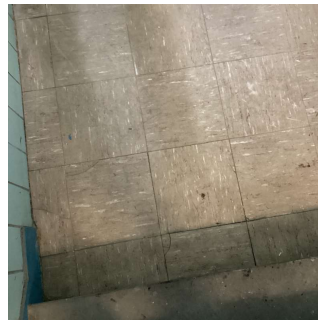

Stair B/Bulkhead

Violations

No violations recorded.

**NYC Department of Education
Building Condition Assessment Survey 2023 - 2024**

Architectural Inspection

Q223

Question	Response
INTERIOR	
STAIRS/RAMPS: INTERIOR	
Walls	Inspected
Condition	2 - Between Good and Fair
Deficiency	GLAZED BLOCK: CRACKS/SPALLING
Deficiency Location/Instance	Stairs A/1,3, F/3
Deficiency Quantity	30
Quantity Uom	S.F.
Potential Action	REPLACE
Urgency of Action	PRIORITY 3
Purpose of Action	LEVEL 2
Deficiency Photo1	
Violations	Stair A/3 No violations recorded.
TOILET ROOMS - STAFF	
Ceiling	Inspected
Condition	2 - Between Good and Fair
Deficiency	No deficiencies recorded
Door(s)	Inspected
Condition	5 - Poor
Deficiency	METAL: DETERIORATED DOOR AND FRAME
Deficiency Location/Instance	Room 105
Deficiency Quantity	1
Quantity Uom	EACH
Potential Action	MAINTENANCE
Urgency of Action	PRIORITY 3
Purpose of Action	LEVEL 2
Deficiency Photo1	
Violations	Room 105 No violations recorded.
Deficiency	WOOD: DAMAGED LOUVER
Deficiency Location/Instance	Room 217
Deficiency Quantity	1
Quantity Uom	EACH

**NYC Department of Education
Building Condition Assessment Survey 2023 - 2024**

Architectural Inspection

Q223

Question	Response
INTERIOR	
TOILET ROOMS - STAFF	
Door(s)	
Potential Action	MAINTENANCE
Urgency of Action	PRIORITY 3
Purpose of Action	LEVEL 2
Deficiency Photo1	
	Room 217
Violations	No violations recorded.
Deficiency	WOOD: DETERIORATED DOOR
Deficiency Location/Instance	Kitchen Office, Rooms 216, 219, 317, 319, In Room 115
Deficiency Quantity	6
Quantity Uom	EACH
Potential Action	MAINTENANCE
Urgency of Action	PRIORITY 3
Purpose of Action	LEVEL 2
Deficiency Photo1	
	Kitchen Office
Violations	No violations recorded.
Floor Finish	Inspected
Condition	2 - Between Good and Fair
Deficiency	No deficiencies recorded
Stalls	Inspected
Condition	5 - Poor
Deficiency	RUST - MAJOR
Deficiency Location/Instance	Rooms 217, 219
Deficiency Quantity	2
Quantity Uom	EACH
Potential Action	REPLACE
Urgency of Action	PRIORITY 3
Purpose of Action	LEVEL 2

**NYC Department of Education
Building Condition Assessment Survey 2023 - 2024**

Architectural Inspection

Q223

Question	Response
----------	----------

INTERIOR

TOILET ROOMS - STAFF

Stalls

Deficiency Photo1



Room 217

Violations

No violations recorded.

Walls

Inspected

Condition

2 - Between Good and Fair

Deficiency

CERAMIC TILE: BROKEN/ MISSING

Deficiency Location/Instance

Rooms 317, 319

Deficiency Quantity

20

Quantity Uom

S.F.

Potential Action

REPLACE

Urgency of Action

PRIORITY 3

Purpose of Action

LEVEL 2

Deficiency Photo1



Room 319

Violations

No violations recorded.

Deficiency

PLASTER: CRACKS/SPALLING

Deficiency Location/Instance

Kitchen Office, Room 219

Deficiency Quantity

20

Quantity Uom

S.F.

Potential Action

REPLACE

Urgency of Action

PRIORITY 3

Purpose of Action

LEVEL 2

Deficiency Photo1

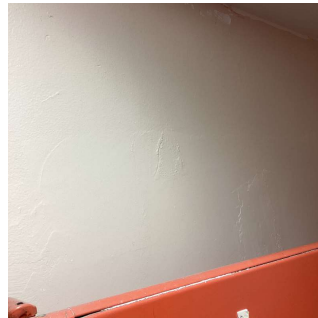

NYC Department of Education
Building Condition Assessment Survey 2023 - 2024

Architectural Inspection

Q223

Question	Response
INTERIOR	
TOILET ROOMS - STAFF	Inspected
Walls	Inspected
Violations	Kitchen Office No violations recorded.
TOILET ROOMS - STUDENTS	Inspected
Ceiling	Inspected
Condition	2 - Between Good and Fair
Deficiency	No deficiencies recorded
Door(s)	Inspected
Condition	5 - Poor
Deficiency	METAL: DETERIORATED DOOR AND FRAME
Deficiency Location/Instance	In Room 129/130
Deficiency Quantity	1
Quantity Uom	EACH
Potential Action	MAINTENANCE
Urgency of Action	PRIORITY 3
Purpose of Action	LEVEL 2
Deficiency Photo1	No photo recorded
Violations	No violations recorded.
Deficiency	WOOD: DETERIORATED DOOR
Deficiency Location/Instance	Rooms 200 Boys, 203 Girls, 213 Boys, 303 Boys, 316, and others
Deficiency Quantity	14
Quantity Uom	EACH
Potential Action	MAINTENANCE
Urgency of Action	PRIORITY 3
Purpose of Action	LEVEL 2
Deficiency Photo1	
Violations	Room 303 Boys No violations recorded.
Floor Finish	Inspected
Condition	2 - Between Good and Fair
Deficiency	CERAMIC TILE: DETERIORATED SUBSTRATE
Deficiency Location/Instance	Room 309 Boys
Deficiency Quantity	10
Quantity Uom	S.F.
Potential Action	REPLACE
Urgency of Action	PRIORITY 3
Purpose of Action	LEVEL 2

**NYC Department of Education
Building Condition Assessment Survey 2023 - 2024**

Architectural Inspection

Q223

Question	Response
----------	----------

INTERIOR

TOILET ROOMS - STUDENTS	Inspected
--------------------------------	-----------

Floor Finish

Deficiency Photo1

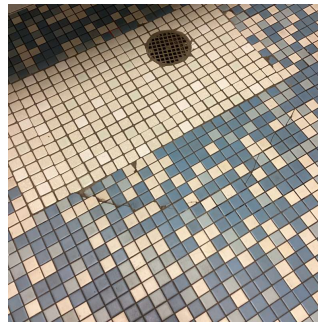

Room 309 Boys

Violations

No violations recorded.

Deficiency	CERAMIC TILE: BROKEN/MISSING TILES
Deficiency Location/Instance	Rooms 209 Boys, 213 Boys, 300 Boys, In Room 120
Deficiency Quantity	40
Quantity Uom	S.F.
Potential Action	REPLACE
Urgency of Action	PRIORITY 3
Purpose of Action	LEVEL 2
Deficiency Photo1	

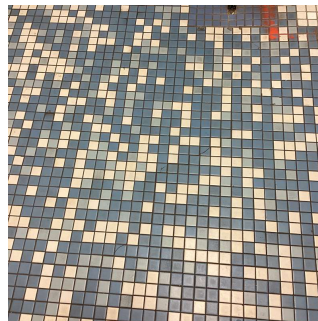

Room 300 Boys

Violations

No violations recorded.

Stalls	Inspected
---------------	-----------

Condition	3 - Fair
-----------	----------

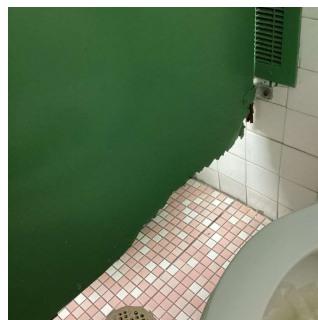

Deficiency	RUST - MAJOR
Deficiency Location/Instance	Rooms 200 Girls, 203 Girls, 313 Boys, 313 Girls
Deficiency Quantity	6
Quantity Uom	EACH
Potential Action	REPLACE
Urgency of Action	PRIORITY 3
Purpose of Action	LEVEL 2
Deficiency Photo1	



**NYC Department of Education
Building Condition Assessment Survey 2023 - 2024**

Architectural Inspection

Q223

Question	Response
INTERIOR	
TOILET ROOMS - STUDENTS	
Stalls	Inspected
	Room 200 Girls
Violations	No violations recorded.
Walls	Inspected
Condition	2 - Between Good and Fair
Deficiency	CERAMIC TILE: BROKEN/ MISSING
Deficiency Location/Instance	Rooms 200 Boys, 203 Girls, 209 Boys, 313 Girls, 318, and others
Deficiency Quantity	120
Quantity Uom	S.F.
Potential Action	REPLACE
Urgency of Action	PRIORITY 3
Purpose of Action	LEVEL 2
Deficiency Photo1	
	Room 318
Violations	No violations recorded.
LIFE SAFETY	
F.D. HOLDING AREA	Inspected
Condition	2 - Between Good and Fair
Deficiency	No deficiencies recorded
STEEL STAIRS	
	Does not Exist
SITE	
CONTAINERIZATION	Inspected
Condition	4 - Between Fair and Poor
Deficiency	CONCRETE PAD DAMAGED
Deficiency Location/Instance	147th Street
Deficiency Quantity	100
Quantity Uom	S.F.
Potential Action	REPAIR
Urgency of Action	PRIORITY 3
Purpose of Action	LEVEL 2
Deficiency Photo1	
	147th Street

**NYC Department of Education
Building Condition Assessment Survey 2023 - 2024**

Architectural Inspection

Q223

Question	Response
SITE	
CONTAINERIZATION	
Violations	No violations recorded.
Deficiency	CONTAINER DAMAGED
Deficiency Location/Instance	147th Street
Deficiency Quantity	1
Quantity Uom	EACH
Potential Action	REPLACE
Urgency of Action	PRIORITY 3
Purpose of Action	LEVEL 2
Deficiency Photo1	
Violations	No violations recorded.
Drainage System for Asphalt	Inspected
Catch Basins/Manhole - Surrounded by asphalt	Inspected
Condition	2 - Between Good and Fair
Deficiency	No deficiencies recorded
Culverts - Asphalt Covering	Does not Exist
Drainage System for Concrete	Inspected
Catch Basins/Manhole - Surrounded by concrete	Inspected
Condition	2 - Between Good and Fair
Deficiency	No deficiencies recorded
Culverts - Concrete Covering	Does not Exist
Drainage System for Soil	Inspected
Catch Basins/Manhole - Surrounded by Soil	Inaccessible
Culverts - Soil Covering	Does not Exist
DRINKING FOUNTAINS	Inspected
Condition	1 - Good
Deficiency	No deficiencies recorded
FENCES	Inspected
Condition	4 - Between Fair and Poor
Deficiency	ALUMINUM: DAMAGED/DETERIORATED
Deficiency Location/Instance	Schoolyard near 147th Street
Deficiency Quantity	40
Quantity Uom	S.F.
Potential Action	REPLACE
Urgency of Action	PRIORITY 3
Purpose of Action	LEVEL 2

**NYC Department of Education
Building Condition Assessment Survey 2023 - 2024**

Architectural Inspection

Q223

Question

Response

SITE

FENCES

Deficiency Photo1

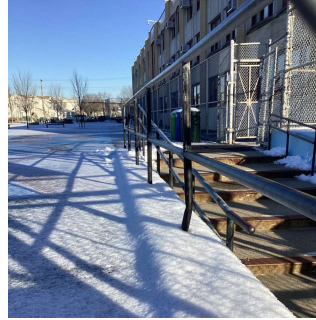

Schoolyard Near 147th Street
No violations recorded.

Violations

Deficiency

CHAIN LINK: DAMAGED/DETERIORATED

Deficiency Location/Instance

Sutphin Boulevard

Deficiency Quantity

100

Quantity Uom

S.F.

Potential Action

REPLACE

Urgency of Action

PRIORITY 3

Purpose of Action

LEVEL 2

Deficiency Photo1



Sutphin Boulevard
No violations recorded.

Violations

Deficiency

CHAIN LINK: DAMAGED POST/RAIL

Deficiency Location/Instance

Sutphin Boulevard

Deficiency Quantity

10

Quantity Uom

L.F.

Potential Action

REPLACE

Urgency of Action

PRIORITY 3

Purpose of Action

LEVEL 2

Deficiency Photo1



Sutphin Boulevard
No violations recorded.

Violations

Deficiency

CONCRETE CURB: DAMAGED/DETERIORATED

NYC Department of Education
Building Condition Assessment Survey 2023 - 2024

Architectural Inspection

Q223

Question	Response
SITE	
FENCES	
Deficiency Location/Instance	147th Street, Sutphin Boulevard
Deficiency Quantity	45
Quantity Uom	S.F.
Potential Action	REPLACE
Urgency of Action	PRIORITY 3
Purpose of Action	LEVEL 2
Deficiency Photo1	
Violations	147th Street No violations recorded.
Deficiency	WROUGHT IRON: DAMAGED/DETERIORATED
Deficiency Location/Instance	South Side of Building, 147th Street
Deficiency Quantity	360
Quantity Uom	S.F.
Potential Action	REPLACE
Urgency of Action	PRIORITY 3
Purpose of Action	LEVEL 2
Deficiency Photo1	
Violations	South Side of Building No violations recorded.
IRRIGATION SYSTEM	Does not Exist
PAVING	Inspected
Student Non-Use	Inspected
Gravel Exists?	No
Asphalt	Does not Exist
Concrete	Inspected
Condition	3 - Fair
Deficiency	DAMAGED/DETERIORATED/MISSING SECTIONS
Deficiency Location/Instance	147th Street
Deficiency Quantity	200
Quantity Uom	S.F.
Potential Action	REPLACE
Urgency of Action	PRIORITY 3

**NYC Department of Education
Building Condition Assessment Survey 2023 - 2024**

Architectural Inspection

Q223

Question	Response
SITE	
PAVING	
Student Non-Use	
Concrete	
Purpose of Action	LEVEL 2
Deficiency Photo1	
	147th Street
Violations	No violations recorded.
Pavers	Does not Exist
Student Use	Inaccessible
Site Sidewalks & Walkways	Inspected
Asphalt	Inspected
Condition	2 - Between Good and Fair
Deficiency	No deficiencies recorded
Concrete	Inspected
Condition	4 - Between Fair and Poor
Deficiency	HEAVING
Deficiency Location/Instance	Near Schoolyard, Sutphin Boulevard
Deficiency Quantity	100
Quantity Uom	S.F.
Potential Action	REPLACE
Urgency of Action	PRIORITY 3
Purpose of Action	LEVEL 2
Deficiency Photo1	
	Near Schoolyard
Violations	No violations recorded.
Deficiency	DAMAGED/DETERIORATED/MISSING SECTIONS
Deficiency Location/Instance	South side of Building, 147th Street, Sutphin Boulevard
Deficiency Quantity	925
Quantity Uom	S.F.
Potential Action	REPLACE
Urgency of Action	PRIORITY 3
Purpose of Action	LEVEL 2

**NYC Department of Education
Building Condition Assessment Survey 2023 - 2024**

Architectural Inspection



Q223

Question	Response
SITE	
PAVING	
Site Sidewalks & Walkways	
Concrete	
Deficiency Photo1	
Violations	South side of Building No violations recorded.
Pavers	Does not Exist
DOT Sidewalk	Inspected
Asphalt	Does not Exist
Concrete	Inspected
Condition	4 - Between Fair and Poor
Deficiency	DAMAGED/DETERIORATED/MISSING SECTIONS
Deficiency Location/Instance	147th Street, Sutphin Boulevard
Deficiency Quantity	550
Quantity Uom	S.F.
Potential Action	REPLACE
Urgency of Action	PRIORITY 3
Purpose of Action	LEVEL 2
Deficiency Photo1	
Violations	147th Street No violations recorded.
Pavers	Does not Exist
PLAYGROUNDS	Inspected
Instance on Schoolyard	Inspected
Instance on South Side of Building	Inspected
Benches	
Instance on Schoolyard	Inspected
Condition	1 - Good
Deficiency	No deficiencies recorded
Instance on South Side of Building	Inspected
Condition	2 - Between Good and Fair
Deficiency	No deficiencies recorded

NYC Department of Education
Building Condition Assessment Survey 2023 - 2024

Architectural Inspection

Q223

Question	Response
SITE	
PLAYGROUNDS	
Fence	
Instance on South Side of Building	Inspected
Condition	2 - Between Good and Fair
Deficiency	WROUGHT IRON: MISSING SECTIONS
Deficiency Location/Instance	Entrance from Sutphin Boulevard
Deficiency Quantity	40
Quantity Uom	S.F.
Potential Action	REPLACE
Urgency of Action	PRIORITY 3
Purpose of Action	LEVEL 2
Deficiency Photo1	
Violations	Entrance from Sutphin Boulevard No violations recorded.
Pavement	
Instance on South Side of Building	Inspected
Condition	3 - Fair
Deficiency	ASPHALT: CRACKS - MAJOR
Deficiency Location/Instance	Near Exit 5
Deficiency Quantity	200
Quantity Uom	S.F.
Potential Action	REPLACE
Urgency of Action	PRIORITY 3
Purpose of Action	LEVEL 2
Deficiency Photo1	
Violations	Near Exit 5 No violations recorded.
Play Equipment	
Instance on Schoolyard	Inspected
Condition	1 - Good
Deficiency	No deficiencies recorded
Instance on South Side of Building	Inspected
Condition	2 - Between Good and Fair

NYC Department of Education
Building Condition Assessment Survey 2023 - 2024

Architectural Inspection

Q223

Question	Response
SITE	
PLAYGROUNDS	
Play Equipment	
Deficiency	No deficiencies recorded
Safety Surfacing	
Instance on Schoolyard	Inaccessible
Instance on South Side of Building	Inaccessible
Unpaved Area	
Instance on Schoolyard	Does not Exist
Instance on South Side of Building	Does not Exist
PLAYING SURFACE	
Playing Field	Inspected
Instance on Schoolyard	Inaccessible
Running Track	
	Does not Exist
RETAINING WALLS	
Are there any Retaining Walls 6' OR higher facing public street/sidewalk?	Inspected
	No
Condition	3 - Fair
Deficiency	CAST IN PLACE CONCRETE: DETERIORATED CONTROL/EXPANSION JOINT
Deficiency Location/Instance	147th Street, Sutphin Boulevard
Deficiency Quantity	20
Quantity Uom	L.F.
Potential Action	REPLACE
Urgency of Action	PRIORITY 3
Purpose of Action	LEVEL 2
Deficiency Photo1	
	147th Street
Violations	No violations recorded.
Deficiency	CAST IN PLACE CONCRETE: CRACKS/SPALLING - MAJOR
Deficiency Location/Instance	147th Street, Sutphin Boulevard
Deficiency Quantity	30
Quantity Uom	S.F.
Potential Action	REPLACE
Urgency of Action	PRIORITY 3
Purpose of Action	LEVEL 2

NYC Department of Education
Building Condition Assessment Survey 2023 - 2024

Architectural Inspection



Q223

Question	Response
SITE	
RETAINING WALLS	
Deficiency Photo1	
Violations	147th Street No violations recorded.
Deficiency	CAST IN PLACE CONCRETE: CRACKS/SPALLING - MINOR
Deficiency Location/Instance	147th Street
Deficiency Quantity	20
Quantity Uom	S.F.
Potential Action	REPAIR
Urgency of Action	PRIORITY 3
Purpose of Action	LEVEL 2
Deficiency Photo1	No photo recorded
Violations	No violations recorded.
SEATING	Inspected
Benches	Inspected
Concrete	Does not Exist
Metal/Wood/Plastic	Inspected
Condition	1 - Good
Deficiency	No deficiencies recorded
Bleachers	Does not Exist
SITE WALLS (NOT RETAINING WALLS)	Does not Exist
STAIRS/RAMPS: EXTERIOR	Inspected
Railings	Inspected
Condition	2 - Between Good and Fair
Deficiency	No deficiencies recorded
Site Cheek/flank Walls	Inspected
Condition	2 - Between Good and Fair
Deficiency	CAST IN PLACE CONCRETE: CRACKS/SPALLING - MAJOR
Deficiency Location/Instance	South side of Building
Deficiency Quantity	10
Quantity Uom	S.F.
Potential Action	REPLACE
Urgency of Action	PRIORITY 3
Purpose of Action	LEVEL 2

**NYC Department of Education
Building Condition Assessment Survey 2023 - 2024**

Architectural Inspection

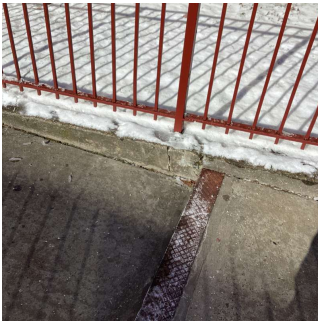
Q223

Question	Response
SITE	
STAIRS/RAMPS: EXTERIOR	
Site Cheek/flank Walls	
Deficiency Photo1	
Violations	South side of Building No violations recorded.
Stairs/ramps	Inspected
Condition	3 - Fair
Deficiency	CAST IN PLACE CONCRETE: CRACKS/SPALLING - MAJOR
Deficiency Location/Instance	South side of Building
Deficiency Quantity	50
Quantity Uom	S.F.
Potential Action	REPLACE
Urgency of Action	PRIORITY 3
Purpose of Action	LEVEL 2
Deficiency Photo1	
Violations	South side of Building No violations recorded.
ARTWORK	Inspected
Instance	Interior - Lobby - 11124
Instance Photo	
	Lobby
Instance ID	11124
Artwork exist at stated location?	Yes