

NYC Department of Education
Building Condition Assessment Survey 2023 - 2024

Architectural Inspection

Q150

Asset: P.S. 150 - QUEENS, 40-01 43 AVENUE, New York, 11104

Inspection Id	Inspection Type	Time In	Last Edited
SA : Q150	Architectural - Senior	2023-11-14 8:29 AM	2024-06-16 7:47 PM
AA : Q150	Architectural - Associate	2023-11-14 7:38 AM	2024-01-03 3:58 PM

Asset Data

Question	Answer
Was the building fully accessible for inspection	No
Inspection Access Comment	Retaining wall, Exterior Walls above 1st Floor, Window lintels, Exterior Guards due to scaffolding and fence.
Building Square Footage	87,000
Comments on the Area (for Athletic Field, Playing Surfaces, Leased Spaces)	None
Comments on the Stories (Floors) plus Basements	4+B
Comments on the Number of Classrooms	60
Comments on the Year Built	1931
Student Population	820
Staff Population	95
Weather	Fair
Principal(s) Information	
Principal Name	Carmen Parache
Organization	P.S. 150 - Queens
Did you meet with this Principal?	No
Did this Principal provide feedback?	Yes
Summary of Principal's Feedback	Assistant Principal Efrain Cordero spoke on behalf of the Principal and had no comments regarding the physical condition of the building at this time.
Custodian	Joseph Mont'etna
Fireman	Mark Weiss
Facade Photo	



Corner of 43rd Avenue and 41st Street - Southeast View

NYC Department of Education
Building Condition Assessment Survey 2023 - 2024

Main Entrance Photo

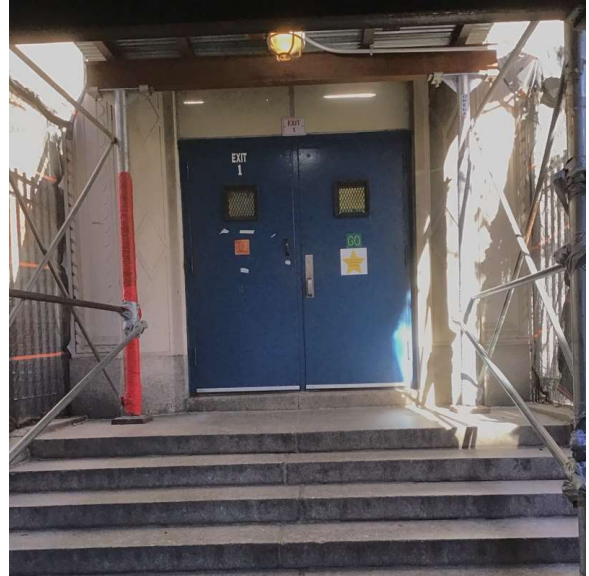

Facade A - 43rd Avenue

Roof Photo



Roof 7 - Southeast View

Have any Systems/Major Building Components been upgraded?

Yes

Systems: Areaways, Bulkheads, Chimney, Coping (Partially - other than Roof 7), Cornice, Exterior Walls (Selective locations at all facades), Parapets (Partially - other than Roof 7), Window Lintels (Selective locations at all facades), Leaders, Gutters, Downspouts, Scuppers, Roof Barriers (Partially - other than Roof 7), Roof hatch, Roof Drains, Roofing (Partially - other than Roof 7), Skylight

Year: Under construction

Systems: Floor Structure, Foundation Walls (waterproofing) - repairs

Year: 2022

Systems: Roofing, Roof Drains (Roof 1) - repairs

Year: 2019

Systems: 1st Floor Student Toilet Rooms HC compliance - upgrade

Year: 2017

Systems: Exterior Doors - repairs

Year: 2012

Systems: (Original Building) Bulkhead, Roofing - repairs; Chimney, Coping, Cornice, Parapets, Exterior Guards, Windows (except Wood) - replacement

Year: 1998

NYC Department of Education
Building Condition Assessment Survey 2023 - 2024

Architectural Inspection

Q150

Have there been any Building Additions?
 Comments on Building Additions
 Tandem Schools?
 Leased Space?

Systems: Roofing (Built-Up) - replacement
 Year: 1980
 Yes
 1998 (+24,000 S.F.)
 No
 No

Priority Condition

Priority Condition Exist Last Year?	Priority Category	Condition Description	Component Affected	Location Description	Person(s) Notified	Person(s) Title	PhotoImage
No	Potential Falling Debris	Deteriorated concrete beam is a potential falling debris hazard.	INTERIOR STRUCTURAL COLUMNS/BEARING WALLS	Basement - Electrical Room	Joseph Mont'etna	Custodian	
No	Potential Falling Debris	Loose ceiling Metal Pan tile is a potential safety hazard.	INTERIOR KITCHEN Ceiling	Near Room A106	Joseph Mont'etna	Custodian	
No	Tripping Hazard	Severely heaving Concrete is a potential tripping hazard.	SITE PAVING DOT Sidewalk Concrete	40th Street	Joseph Mont'etna	Custodian	
Yes	Other	Broken bracket at Exit 5-6 exterior stairs is a potential safety hazard.	EXTERIOR STAIRS/RAMP S: EXTERIOR RAILINGS	Exit 5-6 exterior stairs	Joseph Mont'etna	Custodian	
Yes	Potential Falling Debris	Deteriorated ash hoist door framing is a potential falling debris hazard.	INTERIOR STRUCTURAL VAULTS-BUNKERS Vault/Ash Hoist Doors and Framing	Basement - Electrical Room Vault	Joseph Mont'etna	Custodian	

Structural Engineer Required

Structural Condition Type	Condition Description	Component Affected	Location Description	Person(s) Notified	Person(s) Title	PhotoImage
No condition recorded						

Programmatic Accessibility

Programmatic Accessibility Status Question	Response
Is the primary or secondary entrance on an accessible route?	Yes
Is the building a multi-story building?	Yes
Are all floors of the building accessible through compliant means?	No
Are SOME floors other than the 1st floor and basement accessible through compliant	Yes

NYC Department of Education
Building Condition Assessment Survey 2023 - 2024

Architectural Inspection

Q150

Programmatic Accessibility Status Question	Response
means?	
Is there at least one classroom accessible in the building?	Yes
Is there at least one Boys and Girls or Unisex toilet accessible in the building?	Yes
If the following spaces exist, are SOME accessible? Art Room, Auditorium, Cafeteria, Computer, Gymnasiums, Library, Multipurpose Room, Science Labs	Yes

Physical Breakdown Structure	Exists	Required	Complies	Deficiency	Assistive Listening System	Fire Alarm Strobe
------------------------------	--------	----------	----------	------------	----------------------------------	-------------------------

PROGRAMMATIC ACCESSIBILITY

Exterior Routes

Exterior Entrances & Exits			Yes			
Exterior H/C Lifts	No	No				
Exterior Ramps and Railings	Yes		Yes			

Interior Routes

Corridor and Lobby H/C Lifts	No	Yes				
Interior Corridor Doors and Hardware	Yes		Yes			
Interior Corridors and Lobbies			No	Change in Elevation		
Interior Elevators	Yes		Yes			
Interior Lobby Doors and Hardware			Yes			
Interior Ramps	No					

Rooms & Spaces

Art Rooms		No					
Auditorium	1st Floor	Yes		No	No Stage Access	Induction Loop	Yes
Cafeteria	1st Floor	Yes		Yes		Induction Loop	Yes
Classrooms	1st - 3rd Floors	Yes		Yes			
Computer Rooms	Room 202	Yes		Yes			
Gymnasium	3rd Floor	Yes		No	Not on Accessible Route	Induction Loop	Yes
Library	Room 309	Yes		Yes			
Main Office	Room 201	Yes		Yes			
Multi-purpose Room	1st Floor	Yes		Yes		No	Yes
Nurse's Room	Room 162	Yes		Yes			
Pool		No					
Science Lab		No					
Toilet Rooms (Boys)	1st - 3rd Floors	Yes		Yes			
Toilet Rooms (Girls)	1st - 3rd Floors	Yes		Yes			
Toilet Rooms (Staff)	1st Floor	Yes		Yes			

**NYC Department of Education
Building Condition Assessment Survey 2023 - 2024**

Architectural Inspection

Q150

Building Template

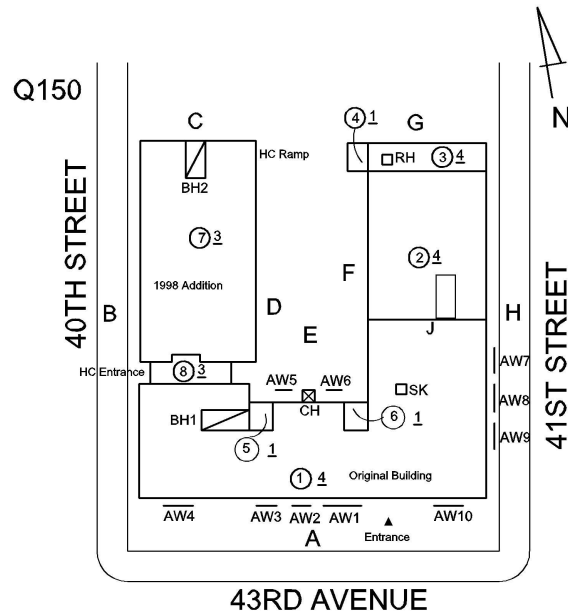

Inspection

Question	Response
Architectural	
EXTERIOR	Inspected
AREAWAY	Inspected
Instance on AW1 - AW11	Under Construction
Instance Quantity	11
Instance Quantity Uom	EACH
AWNINGS AND CANOPIES	Does not Exist
CHIMNEY	Under Construction
COPING	Inspected
Condition	2 - Between Good and Fair
Deficiency	No deficiencies recorded
CORNICE	Under Construction
DOORS	Inspected
DOORS AND FRAMES	Inspected
Condition	2 - Between Good and Fair
Deficiency	No deficiencies recorded
DOOR HARDWARE	Inspected
Condition	3 - Fair
Deficiency	No deficiencies recorded
LINTELS	Inspected
Condition	2 - Between Good and Fair
Deficiency	No deficiencies recorded
TRANSOM/SIDE LIGHT	Inspected
Condition	2 - Between Good and Fair
Deficiency	No deficiencies recorded
EXTERIOR WALLS	Inspected
Material Type(s)	Masonry
Replacement Quantity	47,000
Replacement Uom	S.F.
Instance on All Facades	Under Construction

NYC Department of Education
Building Condition Assessment Survey 2023 - 2024

Architectural Inspection

Q150

Question	Response
EXTERIOR	
EXTERIOR WALLS	
Instance Quantity	47,000
Instance Quantity Uom	S.F.
EXTERIOR SOFFITS	Does not Exist
LOADING DOCK	Does not Exist
LOUVER	Inspected
Condition	2 - Between Good and Fair
Deficiency	No deficiencies recorded
PARAPETS	Inspected
Material Type(s)	Masonry
Replacement Quantity	9,600
Replacement Uom	C.F.
Instance on All Facades	Under Construction
Instance Quantity	9,600
Instance Quantity Uom	C.F.
PLAZA DECK	Does not Exist
ROOF	Inspected
Roofing	Inspected
Replacement Quantity	25,000
Replacement Uom	S.F.
ROOF HATCH/SMOKE HATCH	Under Construction
LEADERS, GUTTERS, DOWNSPOUTS, SCUPPERS	Under Construction
ROOF BARRIER/FENCE	Under Construction
ROOF CAGE	Does not Exist
ROOFING	Inspected
Instance on Built-Up: Roofs 1-6	Under Construction
Instance Quantity	17,000
Instance Quantity Uom	S.F.
Instance on Modified Bitumen: Roofs 7, 8	Under Construction
Instance Quantity	8,000
Instance Quantity Uom	S.F.
ROOFING DRAINS	Under Construction
Specialties	Inspected
BULKHEAD/PENTHOUSE	Inspected
Condition	3 - Fair
Deficiency	BULKHEAD/PENTHOUSE WALLS/EXTERIOR: CRACKS/SPALLING - MINOR
Roof Plan reference	

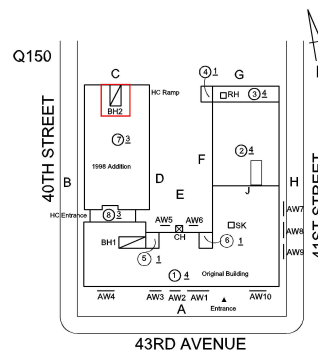

Deficiency Quantity

30

NYC Department of Education
Building Condition Assessment Survey 2023 - 2024

Architectural Inspection

Q150

Question	Response
----------	----------

EXTERIOR

ROOF

Specialties

BULKHEAD/PENTHOUSE

Quantity Uom	S.F.
Potential Action	REPAIR
Urgency of Action	PRIORITY 3
Purpose of Action	LEVEL 2
Deficiency Photo1	



BH2
No violations recorded.

Violations

CUPOLA/ SPIRES/ TOWERS Does not Exist

DORMER Does not Exist

DUNNAGE STEEL Does not Exist

SKYLIGHT/ROOF VENT Under Construction

ROOF/GRAVITY TANK Does not Exist

STAIRS/RAMPS: EXTERIOR Inspected

BUILDING CHEEK/FLANK WALLS Inspected

Condition 2 - Between Good and Fair

Deficiency No deficiencies recorded

RAILINGS Inspected

Condition 3 - Fair

Deficiency RUST - MAJOR

Roof Plan reference

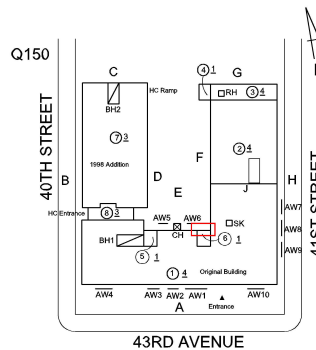

Deficiency Quantity	10
Quantity Uom	L.F.
Potential Action	REPLACE
Urgency of Action	PRIORITY 5
Purpose of Action	LEVEL 2

**NYC Department of Education
Building Condition Assessment Survey 2023 - 2024**

Architectural Inspection

Q150

Question

Response

EXTERIOR

STAIRS/RAMPS: EXTERIOR

RAILINGS

Deficiency Photo1

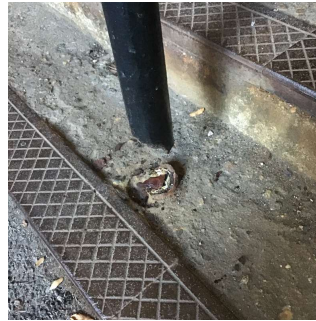

Facade E

Violations

No violations recorded.

Deficiency

BROKEN BRACKET

Roof Plan reference

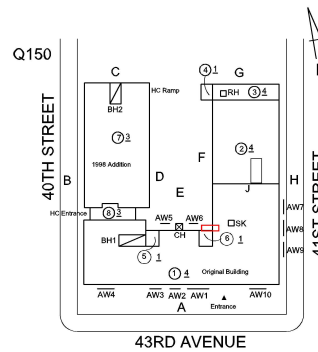

Deficiency Quantity

1

Quantity Uom

EACH

Potential Action

REPLACE

Urgency of Action

PRIORITY 5

Purpose of Action

LEVEL 6

Deficiency Photo1

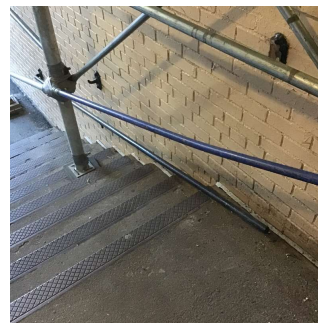

Exit 5-6 Stairs

Violations

No violations recorded.

STAIRS/RAMPS

Inspected

Condition

5 - Poor

Deficiency

CONCRETE: CRACKS/SPALLING - MAJOR

**NYC Department of Education
Building Condition Assessment Survey 2023 - 2024**

Architectural Inspection

Q150

Question

Response

EXTERIOR

STAIRS/RAMPS: EXTERIOR

STAIRS/RAMPS

Roof Plan reference

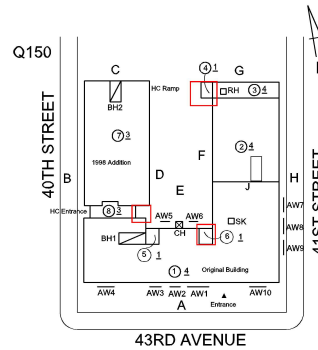

Deficiency Quantity
Quantity Uom
Potential Action
Urgency of Action
Purpose of Action
Deficiency Photo1

30
S.F.
REPLACE
PRIORITY 4
LEVEL 2

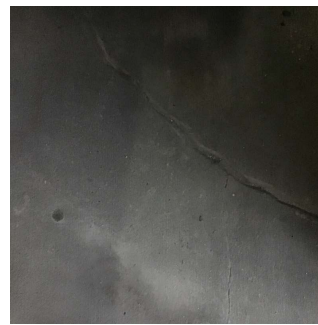

Facade D

No violations recorded.

Violations

Deficiency

CONCRETE: WORN-OUT TREAD/RISER/NOSING

Roof Plan reference

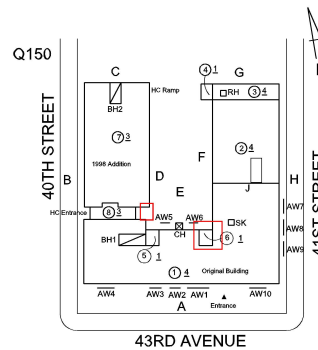

Deficiency Quantity
Quantity Uom
Potential Action
Urgency of Action
Purpose of Action

20
S.F.
REPLACE
PRIORITY 4
LEVEL 2

**NYC Department of Education
Building Condition Assessment Survey 2023 - 2024**

Architectural Inspection

Q150

Question

Response

EXTERIOR

STAIRS/RAMPS: EXTERIOR

STAIRS/RAMPS

Deficiency Photo1



Facade D

No violations recorded.

Violations

Deficiency

CONCRETE: CRACKS/SPALLING - MINOR

Roof Plan reference

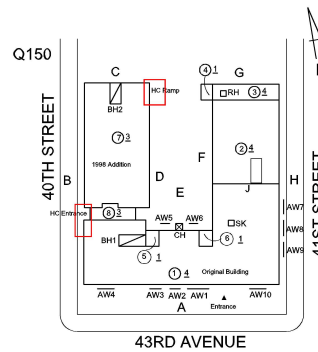

Deficiency Quantity

30

Quantity Uom

S.F.

Potential Action

REPAIR

Urgency of Action

PRIORITY 3

Purpose of Action

LEVEL 2

Deficiency Photo1



Facade B

No violations recorded.

Violations

Deficiency

STONE: DETERIORATED JOINTS

**NYC Department of Education
Building Condition Assessment Survey 2023 - 2024**

Architectural Inspection

Q150

Question

Response

EXTERIOR

STAIRS/RAMPS: EXTERIOR

STAIRS/RAMPS

Roof Plan reference

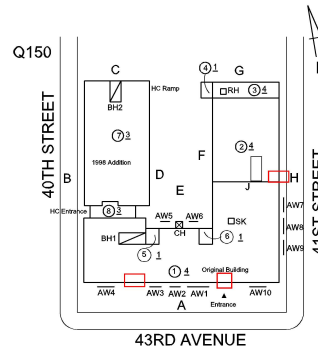

Deficiency Quantity
Quantity Uom
Potential Action
Urgency of Action
Purpose of Action
Deficiency Photo1

25
L.F.
REPOINT
PRIORITY 3
LEVEL 2

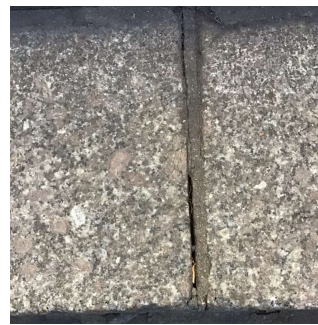

Facade A

No violations recorded.

Violations

Deficiency

STONE: CRACKS/SPALLING - MAJOR

Roof Plan reference

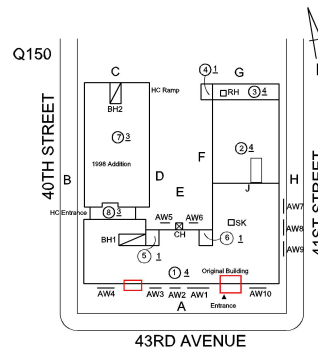

Deficiency Quantity
Quantity Uom
Potential Action
Urgency of Action
Purpose of Action

15
S.F.
REPLACE
PRIORITY 4
LEVEL 2

NYC Department of Education
Building Condition Assessment Survey 2023 - 2024

Architectural Inspection

Q150

Question	Response
----------	----------

EXTERIOR

STAIRS/RAMPS: EXTERIOR

STAIRS/RAMPS

Deficiency Photo1



Facade A

Violations

No violations recorded.

WINDOWS

Inspected

Replacement Quantity

16,000

Replacement Uom

S.F.

EXTERIOR GUARDS

Inaccessible

LINTELS

Inaccessible

WINDOWS

Inspected

Material Type(s)

Aluminum, Solid Wood

Instance on Aluminum - Double Hung: All Facades

Inspected

Instance Condition

3 - Fair

Instance Quantity

15,900

Instance Quantity Uom

S.F.

Are these windows insulated

No

Installation Year

1998

Source of Installation

Custodial Staff

Deficiency

No deficiencies recorded

Instance on Wood: Ash Hoist Vault

Inspected

Instance Condition

5 - Poor

Instance Quantity

100

Instance Quantity Uom

S.F.

Are these windows insulated

No

Installation Year

1931

Source of Installation

Custodial Staff

Deficiency

WOOD: DETERIORATED

Roof Plan reference

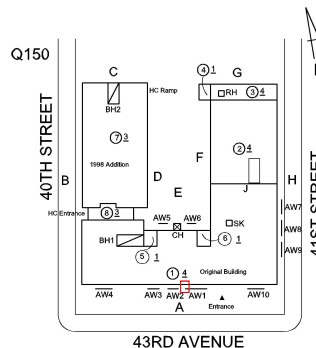

**NYC Department of Education
Building Condition Assessment Survey 2023 - 2024**

Architectural Inspection

Q150

Question	Response
-----------------	-----------------

EXTERIOR

WINDOWS

WINDOWS

Elevation

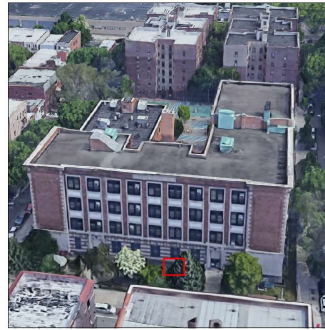

Deficiency Quantity
Quantity Uom
Potential Action
Urgency of Action
Purpose of Action
Deficiency Photo1

30
S.F.
REPLACE WINDOW
PRIORITY 4
LEVEL 2



Basement - Ash Hoist Vault
No violations recorded.

Violations

INTERIOR

Inspected

POOLS

Does not Exist

STRUCTURAL

Inspected

COLUMNS/BEAMS/BEARING WALLS

Inspected

Condition

4 - Between Fair and Poor

Deficiency

CONCRETE COLUMNS/BEAMS:
CRACKED/SPALLED/REINFORCEMENT EXPOSED

Deficiency Location/Instance

Basement - Ash Hoist Vault

Deficiency Quantity

25

Quantity Uom

S.F.

Potential Action

REPLACE

Urgency of Action

PRIORITY 4

Purpose of Action

LEVEL 5



Deficiency Photo1



NYC Department of Education
Building Condition Assessment Survey 2023 - 2024

Architectural Inspection

Q150

Question	Response
INTERIOR	
STRUCTURAL	
COLUMNS/BEAMS/BEARING WALLS	
Violations	Basement - Ash Hoist Vault No violations recorded.
Deficiency	STEEL COLUMNS/BEAMS: DETERIORATED CONCRETE FIREPROOFING
Deficiency Location/Instance	Basement - Workshop
Deficiency Quantity	60
Quantity Uom	S.F.
Potential Action	REPLACE
Urgency of Action	PRIORITY 4
Purpose of Action	LEVEL 5
Deficiency Photo1	
Violations	Basement - Paint Storage Room, Storage Room No violations recorded.
Deficiency	CONCRETE COLUMNS/BEAMS: CRACKED/SPALLED/REINFORCEMENT EXPOSED
Deficiency Location/Instance	Basement - Electrical Room
Deficiency Quantity	20
Quantity Uom	S.F.
Potential Action	REPLACE
Urgency of Action	PRIORITY 5
Purpose of Action	LEVEL 6
Deficiency Photo1	
Violations	Basement - Electrical Room No violations recorded.
FLOOR STRUCTURE	
Condition	Inspected
Deficiency	CONCRETE: CRACKS/SPALLED/REINFORCEMENT EXPOSED
Deficiency Location/Instance	Basement - Ash Hoist Vault
Deficiency Quantity	20
Quantity Uom	S.F.
Potential Action	REPAIR

**NYC Department of Education
Building Condition Assessment Survey 2023 - 2024**

Architectural Inspection

Q150

Question	Response
INTERIOR	
STRUCTURAL	
FLOOR STRUCTURE	
Urgency of Action	PRIORITY 4
Purpose of Action	LEVEL 5
Deficiency Photo1	
	Basement - Vault
Violations	No violations recorded.
Deficiency	CONCRETE SLAB ON GRADE: THRU CRACKS
Deficiency Location/Instance	Basement - Electrical Room
Deficiency Quantity	20
Quantity Uom	S.F.
Potential Action	REPLACE
Urgency of Action	PRIORITY 4
Purpose of Action	LEVEL 5
Deficiency Photo1	
	Basement - Electrical Room
Violations	No violations recorded.
FOUNDATION WALLS	
Material Type(s)	Inspected
	Concrete
Condition	5 - Poor
Deficiency	CONCRETE: WATER INFILTRATION IN ELECTRICAL PANEL ROOM
Deficiency Location/Instance	Basement - Electrical Room
Deficiency Quantity	300
Quantity Uom	S.F.
Potential Action	INSTALL WATERPROOFING
Urgency of Action	PRIORITY 5
Purpose of Action	LEVEL 6

**NYC Department of Education
Building Condition Assessment Survey 2023 - 2024**

Architectural Inspection

Q150

Question

Response

INTERIOR

STRUCTURAL

FOUNDATION WALLS

Deficiency Photo1



Basement - Electrical Room

Violations

No violations recorded.

Deficiency

CONCRETE: CRACKED/SPALLED/REINFORCEMENT EXPOSED

Deficiency Location/Instance

Basement - Oil Tank Room

Deficiency Quantity

50

Quantity Uom

S.F.

Potential Action

REPAIR

Urgency of Action

PRIORITY 4

Purpose of Action

LEVEL 5

Deficiency Photo1



Basement - Oil Tank Room, Boiler Room, Workshop Room

Violations

No violations recorded.

Deficiency

CONCRETE: WATER INFILTRATION IN NON- INSTRUCTIONAL SPACE

Deficiency Location/Instance

Basement - Gas Meter Room, Oil Tank Room, Crawl Space

Deficiency Quantity

300

Quantity Uom

S.F.

Potential Action

INSTALL WATERPROOFING

Urgency of Action

PRIORITY 5

Purpose of Action

LEVEL 5

Deficiency Photo1





K

**NYC Department of Education
Building Condition Assessment Survey 2023 - 2024**

Architectural Inspection

Q150

Question	Response
INTERIOR	
STRUCTURAL	
FOUNDATION WALLS	Inspected
Violations	No violations recorded.
ROOF STRUCTURE	Inspected
Condition	2 - Between Good and Fair
Deficiency	No deficiencies recorded
VAULTS-BUNKERS	Inspected
Foundation Walls	Inspected
Condition	3 - Fair
Deficiency	CRACKS, SPALLING
Deficiency Location/Instance	Basement - Vault Bunker
Deficiency Quantity	20
Quantity Uom	S.F.
Potential Action	REPAIR
Urgency of Action	PRIORITY 4
Purpose of Action	LEVEL 5
Deficiency Photo1	
Violations	Basement - Vault Bunker No violations recorded.
Slab Structure	Inspected
Condition	3 - Fair
Deficiency	CONCRETE SLAB ON GRADE: THRU CRACKS
Deficiency Location/Instance	Basement - Electrical Room Vault
Deficiency Quantity	25
Quantity Uom	S.F.
Potential Action	REPLACE
Urgency of Action	PRIORITY 4
Purpose of Action	LEVEL 5
Deficiency Photo1	
Violations	Basement - Electrical Room Vault No violations recorded.
Vault/Ash Hoist Doors and Framing	Inspected
Condition	5 - Poor

**NYC Department of Education
Building Condition Assessment Survey 2023 - 2024**

Architectural Inspection

Q150

Question	Response
INTERIOR	
STRUCTURAL	
VAULTS-BUNKERS	
Vault/Ash Hoist Doors and Framing	
Deficiency	WATER INFILTRATION
Deficiency Location/Instance	Basement - Electrical Room Vault
Deficiency Quantity	10
Quantity Uom	S.F.
Potential Action	REPAIR
Urgency of Action	PRIORITY 5
Purpose of Action	LEVEL 2
Deficiency Photo1	
Violations	Basement - Electrical Room Vault No violations recorded.
Deficiency	DETERIORATED/DAMAGED VAULT/ASH HOIST DOORS AND FRAMING
Deficiency Location/Instance	Basement - Electrical Room Vault
Deficiency Quantity	2
Quantity Uom	EACH
Potential Action	REPLACE
Urgency of Action	PRIORITY 5
Purpose of Action	LEVEL 6
Deficiency Photo1	
Violations	Basement - Electrical Room Vault No violations recorded.
AUDITORIUM	
	Inspected
Instance on 1st Floor (559 Seats)	Inspected
Ceiling	
Instance on 1st Floor (559 Seats)	Inspected
Condition	2 - Between Good and Fair
Deficiency	PLASTER: CRACKS/SPALLING
Deficiency Location/Instance	Near Windows
Deficiency Quantity	10
Quantity Uom	S.F.

**NYC Department of Education
Building Condition Assessment Survey 2023 - 2024**

Architectural Inspection

Q150

Question	Response
----------	----------

INTERIOR

AUDITORIUM

Ceiling

Potential Action	REPLACE
Urgency of Action	PRIORITY 3
Purpose of Action	LEVEL 2
Deficiency Photo1	



Near Windows

Violations	No violations recorded.
------------	-------------------------

Door(s)

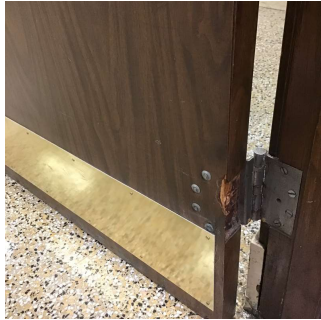
Instance on 1st Floor (559 Seats)	Inspected
Condition	5 - Poor
Deficiency	WOOD: DETERIORATED DOOR
Deficiency Location/Instance	Entrances
Deficiency Quantity	4
Quantity Uom	EACH
Potential Action	MAINTENANCE
Urgency of Action	PRIORITY 3
Purpose of Action	LEVEL 2
Deficiency Photo1	

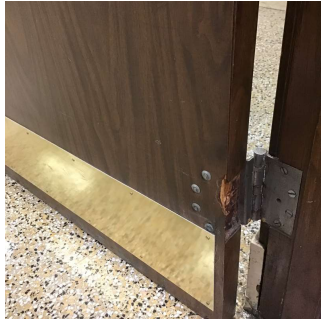

Entrance

Violations	No violations recorded.
------------	-------------------------

Fixed H/C Lift

Instance on 1st Floor (559 Seats)	Does not Exist
-----------------------------------	----------------

Fixed Seating

Instance on 1st Floor (559 Seats)	Inspected
Condition	5 - Poor
Deficiency	DAMAGED/BROKEN/INOPERABLE
Deficiency Location/Instance	Seats A/2, C/13, F/11, 12, 14, 17, 21, 23, K/4, 24, 26, T/22
Deficiency Quantity	12
Quantity Uom	EACH
Potential Action	REPLACE
Urgency of Action	PRIORITY 5
Purpose of Action	LEVEL 6

**NYC Department of Education
Building Condition Assessment Survey 2023 - 2024**

Architectural Inspection

Q150

Question

Response

INTERIOR

AUDITORIUM

Fixed Seating

Deficiency Photo1



Seat K/4

Violations

No violations recorded.

Deficiency

DAMAGED/BROKEN/INOPERABLE

Deficiency Location/Instance

Seats C/2, 26, L/4, U/5, 22, and others.

Deficiency Quantity

45

Quantity Uom

EACH

Potential Action

REPLACE

Urgency of Action

PRIORITY 3

Purpose of Action

LEVEL 2

Deficiency Photo1



Seat L/4

Violations

No violations recorded.

Floor Finish

Instance on 1st Floor (559 Seats)

Inspected

Condition

2 - Between Good and Fair

Deficiency

VINYL TILES: BROKEN/DETERIORATED/MISSING TILES

Deficiency Location/Instance

Storage Room - 2nd Floor

Deficiency Quantity

10

Quantity Uom

S.F.

Potential Action

REPLACE

Urgency of Action

PRIORITY 3

Purpose of Action

LEVEL 2

**NYC Department of Education
Building Condition Assessment Survey 2023 - 2024**

Architectural Inspection

Q150

Question	Response
INTERIOR	
AUDITORIUM	
Floor Finish	
Deficiency Photo1	
Violations	Storage Room - 2nd Floor No violations recorded.
Deficiency	CONCRETE: CRACKS
Deficiency Location/Instance	Near Seat O/25, W/6,
Deficiency Quantity	30
Quantity Uom	S.F.
Potential Action	REPLACE
Urgency of Action	PRIORITY 3
Purpose of Action	LEVEL 2
Deficiency Photo1	
Violations	Near Seat W/6 No violations recorded.
Sliding-folding Partition	
Instance on 1st Floor (559 Seats)	Does not Exist
Stage	
Instance on 1st Floor (559 Seats)	Inspected
Stage	
Instance on 1st Floor (559 Seats)	Inspected
Condition	3 - Fair
Deficiency	DAMAGED STEPS
Deficiency Location/Instance	Right , left
Deficiency Quantity	10
Quantity Uom	S.F.
Potential Action	REPLACE
Urgency of Action	PRIORITY 3
Purpose of Action	LEVEL 2

**NYC Department of Education
Building Condition Assessment Survey 2023 - 2024**

Architectural Inspection



Q150

Question	Response
INTERIOR	
AUDITORIUM	
Stage	
Stage	
Deficiency Photo1	
	Left side
Violations	No violations recorded.
Deficiency	DAMAGED FASCIA
Deficiency Location/Instance	Near Center
Deficiency Quantity	30
Quantity Uom	S.F.
Potential Action	REPLACE
Urgency of Action	PRIORITY 3
Purpose of Action	LEVEL 2
Deficiency Photo1	
	Near Center
Violations	No violations recorded.
Stage Curtain Rigging	Inspected
Instance on 1st Floor (559 Seats)	Inspected
Condition	1 - Good
Deficiency	No deficiencies recorded
Stage Curtains	Inspected
Instance on 1st Floor (559 Seats)	Inspected
Condition	1 - Good
Deficiency	No deficiencies recorded
Walls	
Instance on 1st Floor (559 Seats)	Inspected
Condition	2 - Between Good and Fair
Deficiency	STONE: CRACKS/SPALLING
Deficiency Location/Instance	Right, left
Deficiency Quantity	40
Quantity Uom	S.F.
Potential Action	REPLACE
Urgency of Action	PRIORITY 3

**NYC Department of Education
Building Condition Assessment Survey 2023 - 2024**

Architectural Inspection

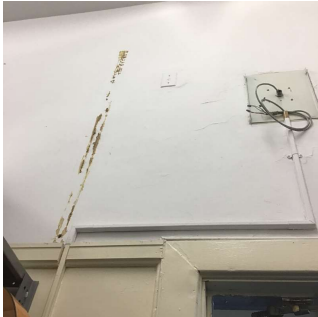
Q150

Question	Response
INTERIOR	
AUDITORIUM	
Walls	
Purpose of Action	LEVEL 2
Deficiency Photo1	
Violations	Left side No violations recorded.
Deficiency	PLASTER: CRACKS/SPALLING
Deficiency Location/Instance	Storage Room - 2nd Floor
Deficiency Quantity	20
Quantity Uom	S.F.
Potential Action	REPLACE
Urgency of Action	PRIORITY 3
Purpose of Action	LEVEL 2
Deficiency Photo1	
Violations	Storage Room - 2nd Floor No violations recorded.
Deficiency	STONE MOLDINGS: CRACKS/SPALLING
Deficiency Location/Instance	Near Windows
Deficiency Quantity	30
Quantity Uom	L.F.
Potential Action	REPLACE
Urgency of Action	PRIORITY 3
Purpose of Action	LEVEL 2
Deficiency Photo1	
Violations	Near Windows

**NYC Department of Education
Building Condition Assessment Survey 2023 - 2024**

Architectural Inspection

Q150

Question	Response
INTERIOR	
AUDITORIUM	
Walls	
Violations	No violations recorded.
Window Curtains/Shades/Blinds	
Instance on 1st Floor (559 Seats)	Inspected
Condition	2 - Between Good and Fair
Deficiency	No deficiencies recorded
CAFETERIA	
Instance on 1st Floor	Inspected
Ceiling	
Instance on 1st Floor	Inspected
Condition	2 - Between Good and Fair
Deficiency	ACOUSTIC TILES: DAMAGED/MISSING
Deficiency Location/Instance	Near Kitchen, Windows
Deficiency Quantity	50
Quantity Uom	S.F.
Potential Action	REPLACE
Urgency of Action	PRIORITY 3
Purpose of Action	LEVEL 2
Deficiency Photo1	
	Near Kitchen
Violations	No violations recorded.
Door(s)	
Instance on 1st Floor	Inspected
Condition	2 - Between Good and Fair
Deficiency	No deficiencies recorded
Fixed Equipment	
Instance on 1st Floor	Does not Exist
Floor Finish	
Instance on 1st Floor	Inspected
Condition	2 - Between Good and Fair
Deficiency	VINYL TILES: DETERIORATED SUBSTRATE
Deficiency Location/Instance	Near Windows, Center
Deficiency Quantity	30
Quantity Uom	S.F.
Potential Action	REPLACE
Urgency of Action	PRIORITY 3
Purpose of Action	LEVEL 2

**NYC Department of Education
Building Condition Assessment Survey 2023 - 2024**

Architectural Inspection



Q150

Question	Response
INTERIOR	
CAFETERIA	
Floor Finish	
Deficiency Photo1	
Violations	Near Windows No violations recorded.
Deficiency	VINYL TILES: BROKEN/DETERIORATED/MISSING TILES
Deficiency Location/Instance	Near Elevator 1A, Kitchen, Center
Deficiency Quantity	60
Quantity Uom	S.F.
Potential Action	REPLACE
Urgency of Action	PRIORITY 3
Purpose of Action	LEVEL 2
Deficiency Photo1	
Violations	Near Elevator 1A No violations recorded.
Sliding-folding Partition	
Instance on 1st Floor	Does not Exist
Stage	
Instance on 1st Floor	Does not Exist
Walls	
Instance on 1st Floor	Inspected
Condition	2 - Between Good and Fair
Deficiency	No deficiencies recorded
Window Curtains/Shades/Blinds	
Instance on 1st Floor	Does not Exist
CLASSROOMS/CORRIDORS/ADMIN SPACES	
Ceiling	
Condition	Inspected 2 - Between Good and Fair
Deficiency	ACOUSTIC TILES: DAMAGED/MISSING
Deficiency Location/Instance	Rooms 162, 228, 229
Deficiency Quantity	30
Quantity Uom	S.F.
Potential Action	REPLACE

**NYC Department of Education
Building Condition Assessment Survey 2023 - 2024**

Architectural Inspection

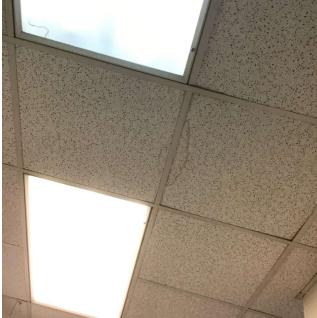
Q150

Question	Response
INTERIOR	
CLASSROOMS/CORRIDORS/ADMIN SPACES	
Ceiling	
Urgency of Action	PRIORITY 3
Purpose of Action	LEVEL 2
Deficiency Photo1	
	Room 162
Violations	No violations recorded.
Door(s)	Inspected
Condition	5 - Poor
Deficiency	METAL CLAD WOOD: DETERIORATED DOOR
Deficiency Location/Instance	Room 369
Deficiency Quantity	1
Quantity Uom	EACH
Potential Action	MAINTENANCE
Urgency of Action	PRIORITY 3
Purpose of Action	LEVEL 2
Deficiency Photo1	
	Room 369
Violations	No violations recorded.
Deficiency	WOOD: DETERIORATED DOOR
Deficiency Location/Instance	Rooms 150, 202, 215, 303, 317, and others.
Deficiency Quantity	8
Quantity Uom	EACH
Potential Action	MAINTENANCE
Urgency of Action	PRIORITY 3
Purpose of Action	LEVEL 2

**NYC Department of Education
Building Condition Assessment Survey 2023 - 2024**

Architectural Inspection

Q150

Question	Response
----------	----------

INTERIOR

CLASSROOMS/CORRIDORS/ADMIN SPACES

Door(s)

Deficiency Photo1



Room 202

Violations

No violations recorded.

Floor Finish

Inspected

Condition

2 - Between Good and Fair

Deficiency

TERRAZZO: CRACKS

Deficiency Location/Instance

Corridor near Room 101

Deficiency Quantity

10

Quantity Uom

S.F.

Potential Action

REPLACE

Urgency of Action

PRIORITY 3

Purpose of Action

LEVEL 2

Deficiency Photo1



Corridor near Room 101

Violations

No violations recorded.

Deficiency

VINYL TILES: DETERIORATED SUBSTRATE

Deficiency Location/Instance

Rooms 224, 225, 227, 229

Deficiency Quantity

80

Quantity Uom

S.F.

Potential Action

REPLACE

Urgency of Action

PRIORITY 3

Purpose of Action

LEVEL 2

Deficiency Photo1



**NYC Department of Education
Building Condition Assessment Survey 2023 - 2024**

Architectural Inspection



Q150

Question	Response
INTERIOR	
CLASSROOMS/CORRIDORS/ADMIN SPACES	
Floor Finish	
Violations	Room 229 No violations recorded.
Deficiency	VINYL TILES: BROKEN/DETERIORATED/MISSING TILES
Deficiency Location/Instance	Rooms 150, 205, 219, 229, Corridor near Room A202, and others.
Deficiency Quantity	150
Quantity Uom	S.F.
Potential Action	REPLACE
Urgency of Action	PRIORITY 3
Purpose of Action	LEVEL 2
Deficiency Photo1	
Violations	Room 205 No violations recorded.
Walls	Inspected
Condition	2 - Between Good and Fair
Deficiency	STONE: CRACKS/SPALLING
Deficiency Location/Instance	Corridor near Room 101
Deficiency Quantity	25
Quantity Uom	S.F.
Potential Action	REPLACE
Urgency of Action	PRIORITY 3
Purpose of Action	LEVEL 2
Deficiency Photo1	
Violations	Corridor near Room 101 No violations recorded.
Deficiency	PLASTER: CRACKS/SPALLING - ACTIVE LEAK
Deficiency Location/Instance	Rooms 205, 215, 305
Deficiency Quantity	40
Quantity Uom	S.F.
Potential Action	REPLACE
Urgency of Action	PRIORITY 5
Purpose of Action	LEVEL 2

**NYC Department of Education
Building Condition Assessment Survey 2023 - 2024**

Architectural Inspection

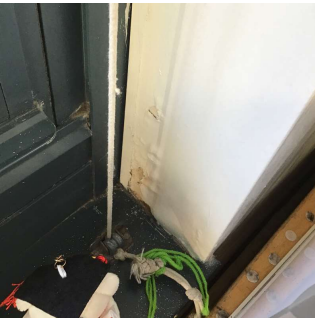
Q150

Question	Response
INTERIOR	
CLASSROOMS/CORRIDORS/ADMIN SPACES	
Walls	
Deficiency Photo1 Violations	 Room 305 No violations recorded.
Deficiency Deficiency Location/Instance Deficiency Quantity Quantity Uom Potential Action Urgency of Action Purpose of Action Deficiency Photo1 Violations	GYPSUM BOARD: DETERIORATED - ACTIVE LEAK Room 329 10 S.F. REPLACE PRIORITY 5 LEVEL 2  Room 329 No violations recorded.
Deficiency Deficiency Location/Instance Deficiency Quantity Quantity Uom Potential Action Urgency of Action Purpose of Action Deficiency Photo1 Violations	PLASTER: CRACKS/SPALLING Rooms 217, 219, 229, 315, 319, and others. 80 S.F. REPLACE PRIORITY 3 LEVEL 2  Room 319 No violations recorded.

**NYC Department of Education
Building Condition Assessment Survey 2023 - 2024**

Architectural Inspection

Q150

Question	Response
INTERIOR	
CLASSROOMS/CORRIDORS/ADMIN SPACES	
Walls	
Deficiency	GYPSUM BOARD: DETERIORATED
Deficiency Location/Instance	Rooms A202, 326, 330, Corridor near Room 325, 329, and others.
Deficiency Quantity	120
Quantity Uom	S.F.
Potential Action	REPLACE
Urgency of Action	PRIORITY 3
Purpose of Action	LEVEL 2
Deficiency Photo1	
Violations	Room 326 No violations recorded.
Specialties	Does not Exist
GYMNASIUM	
Instance on 3rd Floor	Inspected
Ceiling	Inspected
Instance on 3rd Floor	Inspected
Condition	2 - Between Good and Fair
Deficiency	PLASTER: CRACKS/SPALLING
Deficiency Location/Instance	Office
Deficiency Quantity	10
Quantity Uom	S.F.
Potential Action	REPLACE
Urgency of Action	PRIORITY 3
Purpose of Action	LEVEL 2
Deficiency Photo1	
Violations	Office No violations recorded.
Door(s)	
Instance on 3rd Floor	Inspected
Condition	5 - Poor
Deficiency	WOOD: DETERIORATED DOOR
Deficiency Location/Instance	Entrance, Storage Room, Office/Storage Room, Office

**NYC Department of Education
Building Condition Assessment Survey 2023 - 2024**

Architectural Inspection

Q150

Question	Response
INTERIOR	
GYMNASIUM	
Door(s)	
Deficiency Quantity	5
Quantity Uom	EACH
Potential Action	MAINTENANCE
Urgency of Action	PRIORITY 3
Purpose of Action	LEVEL 2
Deficiency Photo1	
Violations	Entrance No violations recorded.
Fixed Equipment	
Instance on 3rd Floor	Inspected
Condition	2 - Between Good and Fair
Deficiency	No deficiencies recorded
Floor Finish	
Instance on 3rd Floor	Inspected
Condition	2 - Between Good and Fair
Deficiency	WOOD: DAMAGED/DETERIORATED
Deficiency Location/Instance	Left side
Deficiency Quantity	50
Quantity Uom	S.F.
Potential Action	REPLACE
Urgency of Action	PRIORITY 3
Purpose of Action	LEVEL 2
Deficiency Photo1	
Violations	Left side No violations recorded.
Seating	
Instance on 3rd Floor	Inspected
Condition	5 - Poor
Deficiency	DAMAGED FIXED SEATING
Deficiency Location/Instance	Near Windows Left Side and Right side.
Deficiency Quantity	4

**NYC Department of Education
Building Condition Assessment Survey 2023 - 2024**

Architectural Inspection

Q150

Question	Response
INTERIOR	
GYMNASIUM	
Seating	
Quantity Uom	EACH
Potential Action	REPLACE
Urgency of Action	PRIORITY 3
Purpose of Action	LEVEL 2
Deficiency Photo1	
	Near Windows Left Side
Violations	No violations recorded.
Sliding-folding Partition	
Instance on 3rd Floor	Does not Exist
Stage	
Instance on 3rd Floor	Does not Exist
Walls	
Instance on 3rd Floor	Inspected
Condition	2 - Between Good and Fair
Deficiency	PLASTER: CRACKS/SPALLING
Deficiency Location/Instance	Office/Storage Room
Deficiency Quantity	20
Quantity Uom	S.F.
Potential Action	REPLACE
Urgency of Action	PRIORITY 3
Purpose of Action	LEVEL 2
Deficiency Photo1	
	Office/Storage Room
Violations	No violations recorded.
Deficiency	SALT GLAZED BRICK: CRACKS/SPALLING
Deficiency Location/Instance	Near Windows
Deficiency Quantity	30
Quantity Uom	S.F.
Potential Action	REPLACE
Urgency of Action	PRIORITY 3
Purpose of Action	LEVEL 2

NYC Department of Education
Building Condition Assessment Survey 2023 - 2024

Architectural Inspection

Q150

Question	Response
INTERIOR	
GYMNASIUM	
Walls	
Deficiency Photo1	
Violations	Near Windows No violations recorded.
Window Curtains/Shades/Blinds	
Instance on 3rd Floor	Does not Exist
INTERIOR DOOR HARDWARE	
Condition	Inspected 3 - Fair
Deficiency	No deficiencies recorded
INTERIOR GUARDS	
Condition	Inspected 2 - Between Good and Fair
Deficiency	No deficiencies recorded
KITCHEN	
Instance on 1st Floor	Inspected
Ceiling	
Instance on 1st Floor	Inspected
Condition	3 - Fair
Deficiency	METAL PAN: DAMAGED/MISSING
Deficiency Location/Instance	Near Room A106
Deficiency Quantity	10
Quantity Uom	S.F.
Potential Action	REPLACE
Urgency of Action	PRIORITY 5
Purpose of Action	LEVEL 6
Deficiency Photo1	
Violations	Near Room A106 No violations recorded.
Deficiency	ACOUSTIC TILES: DAMAGED/MISSING
Deficiency Location/Instance	Room A106, A107, A113
Deficiency Quantity	30
Quantity Uom	S.F.
Potential Action	REPLACE

**NYC Department of Education
Building Condition Assessment Survey 2023 - 2024**

Architectural Inspection



Q150

Question	Response
INTERIOR	
KITCHEN	
Ceiling	
Urgency of Action	PRIORITY 3
Purpose of Action	LEVEL 2
Deficiency Photo1	
	Room A107
Violations	No violations recorded.
Door(s)	
Instance on 1st Floor	Inspected
Condition	2 - Between Good and Fair
Deficiency	No deficiencies recorded
Floor Finish	
Instance on 1st Floor	Inspected
Condition	2 - Between Good and Fair
Deficiency	VINYL TILES: BROKEN/DETERIORATED/MISSING TILES
Deficiency Location/Instance	Room A106
Deficiency Quantity	10
Quantity Uom	S.F.
Potential Action	REPLACE
Urgency of Action	PRIORITY 3
Purpose of Action	LEVEL 2
Deficiency Photo1	
	Room A106
Violations	No violations recorded.
Deficiency	VINYL TILES: DETERIORATED SUBSTRATE
Deficiency Location/Instance	Room A108
Deficiency Quantity	10
Quantity Uom	S.F.
Potential Action	REPLACE
Urgency of Action	PRIORITY 3
Purpose of Action	LEVEL 2

**NYC Department of Education
Building Condition Assessment Survey 2023 - 2024**

Architectural Inspection



Q150

Question	Response
INTERIOR	
KITCHEN	
Floor Finish	
Deficiency Photo1	
Violations	Room A108 No violations recorded.
Walls	
Instance on 1st Floor	Inspected
Condition	2 - Between Good and Fair
Deficiency	GYP SUM BOARD: DETERIORATED
Deficiency Location/Instance	Room A108
Deficiency Quantity	10
Quantity Uom	S.F.
Potential Action	REPLACE
Urgency of Action	PRIORITY 3
Purpose of Action	LEVEL 2
Deficiency Photo1	
Violations	Room A108 No violations recorded.
Deficiency	MASONRY: CRACKS/SPALLING
Deficiency Location/Instance	Rooms A108, A113
Deficiency Quantity	10
Quantity Uom	S.F.
Potential Action	REPLACE
Urgency of Action	PRIORITY 3
Purpose of Action	LEVEL 2

**NYC Department of Education
Building Condition Assessment Survey 2023 - 2024**

Architectural Inspection

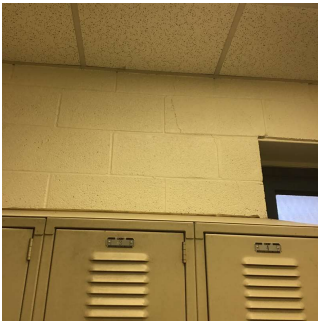
Q150

Question	Response
INTERIOR	
KITCHEN	Inspected
Walls	
Deficiency Photo1	
Violations	Room A108 No violations recorded.
LIBRARY	Inspected
Instance on Room 309	Inspected
Built-in Furnishing	
Instance on Room 309	Inspected
Condition	2 - Between Good and Fair
Deficiency	SINK/STORAGE CABINET - DAMAGED/DETERIORATED
Deficiency Location/Instance	Near Center
Deficiency Quantity	10
Quantity Uom	L.F.
Potential Action	REPLACE
Urgency of Action	PRIORITY 3
Purpose of Action	LEVEL 2
Deficiency Photo1	
Violations	Near Center No violations recorded.
Ceiling	
Instance on Room 309	Inspected
Condition	2 - Between Good and Fair
Deficiency	No deficiencies recorded
Door(s)	
Instance on Room 309	Inspected
Condition	2 - Between Good and Fair
Deficiency	WOOD: DETERIORATED DOOR
Deficiency Location/Instance	Room 309
Deficiency Quantity	1
Quantity Uom	EACH
Potential Action	MAINTENANCE
Urgency of Action	PRIORITY 3

**NYC Department of Education
Building Condition Assessment Survey 2023 - 2024**

Architectural Inspection

Q150

Question	Response
INTERIOR	
LIBRARY	Inspected
Door(s)	
Purpose of Action	LEVEL 2
Deficiency Photo1	
	Room 309
Violations	No violations recorded.

Floor Finish

Instance on Room 309	Inspected
Condition	2 - Between Good and Fair
Deficiency	CONCRETE: CRACKS
Deficiency Location/Instance	Near Center
Deficiency Quantity	10
Quantity Uom	S.F.
Potential Action	REPLACE
Urgency of Action	PRIORITY 3
Purpose of Action	LEVEL 2
Deficiency Photo1	
	Near Center
Violations	No violations recorded.

Walls

Instance on Room 309	Inspected
Condition	2 - Between Good and Fair
Deficiency	PLASTER: CRACKS/SPALLING
Deficiency Location/Instance	Near Entrance
Deficiency Quantity	10
Quantity Uom	S.F.
Potential Action	REPLACE
Urgency of Action	PRIORITY 3
Purpose of Action	LEVEL 2

**NYC Department of Education
Building Condition Assessment Survey 2023 - 2024**

Architectural Inspection



Q150

Question	Response
INTERIOR	
LIBRARY	
Walls	
Deficiency Photo1	
Violations	Near Entrance No violations recorded.
LOCKER ROOM	Does not Exist
MULTI-PURPOSE ROOM	Inspected
Instance on 1st Floor	Inspected
Ceiling	
Instance on 1st Floor	Inspected
Condition	2 - Between Good and Fair
Deficiency	PLASTER: CRACKS/SPALLING
Deficiency Location/Instance	Near Stair D
Deficiency Quantity	10
Quantity Uom	S.F.
Potential Action	REPLACE
Urgency of Action	PRIORITY 3
Purpose of Action	LEVEL 2
Deficiency Photo1	
Violations	Near Stair D No violations recorded.
Door(s)	
Instance on 1st Floor	Inspected
Condition	2 - Between Good and Fair
Deficiency	No deficiencies recorded
Fixed Equipment	
Instance on 1st Floor	Does not Exist
Floor Finish	
Instance on 1st Floor	Inspected
Condition	2 - Between Good and Fair
Deficiency	VINYL TILES: DETERIORATED SUBSTRATE
Deficiency Location/Instance	Near Exit 2, center.
Deficiency Quantity	20

**NYC Department of Education
Building Condition Assessment Survey 2023 - 2024**

Architectural Inspection

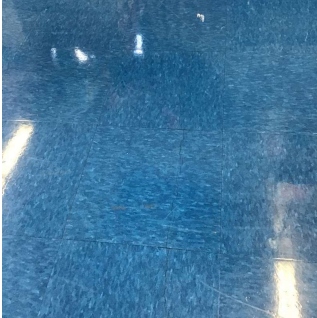
Q150

Question	Response
INTERIOR	
MULTI-PURPOSE ROOM	
Floor Finish	
Quantity Uom	S.F.
Potential Action	REPLACE
Urgency of Action	PRIORITY 3
Purpose of Action	LEVEL 2
Deficiency Photo1	
	Near Exit 2
Violations	No violations recorded.
Sliding-folding Partition	
Instance on 1st Floor	Does not Exist
Stage	
Instance on 1st Floor	Does not Exist
Walls	
Instance on 1st Floor	Inspected
Condition	2 - Between Good and Fair
Deficiency	SALT GLAZED BRICK: CRACKS/SPALLING
Deficiency Location/Instance	Near Windows
Deficiency Quantity	10
Quantity Uom	S.F.
Potential Action	REPLACE
Urgency of Action	PRIORITY 3
Purpose of Action	LEVEL 2
Deficiency Photo1	
	Near Windows
Violations	No violations recorded.
Deficiency	PLASTER: CRACKS/SPALLING
Deficiency Location/Instance	Corridor near Room 169
Deficiency Quantity	10
Quantity Uom	S.F.
Potential Action	REPLACE
Urgency of Action	PRIORITY 3
Purpose of Action	LEVEL 2

**NYC Department of Education
Building Condition Assessment Survey 2023 - 2024**

Architectural Inspection

Q150

Question	Response
INTERIOR	
MULTI-PURPOSE ROOM	
Walls	
Deficiency Photo1	
Violations	Corridor near Room 169 No violations recorded.
Window Curtains/Shades/Blinds	
Instance on 1st Floor	Does not Exist
SCIENCE DEMO ROOM	Does not Exist
SCIENCE LAB	Does not Exist
SCIENCE PREP ROOM	Does not Exist
SHOWER ROOM	Does not Exist
STAIRS/RAMPS: INTERIOR	
Do Letter Stair Signs Exist?	Inspected Yes
Ceiling	
Condition	Inspected 2 - Between Good and Fair
Deficiency	PLASTER: CRACKS/SPALLING
Deficiency Location/Instance	Stair B/3, CD/1, Vest G/2
Deficiency Quantity	30
Quantity Uom	S.F.
Potential Action	REPLACE
Urgency of Action	PRIORITY 3
Purpose of Action	LEVEL 2
Deficiency Photo1	
Violations	Stair CD/1 No violations recorded.
Door(s)	
Condition	Inspected 4 - Between Fair and Poor
Deficiency	METAL CLAD WOOD: DETERIORATED DOOR
Deficiency Location/Instance	Stairs CD/1, EF/2
Deficiency Quantity	2
Quantity Uom	EACH
Potential Action	MAINTENANCE

**NYC Department of Education
Building Condition Assessment Survey 2023 - 2024**

Architectural Inspection

Q150

Question	Response
INTERIOR	
STAIRS/RAMPS: INTERIOR	
Door(s)	
Urgency of Action	PRIORITY 3
Purpose of Action	LEVEL 2
Deficiency Photo1	
	Stair EF/2
Violations	No violations recorded.
Deficiency	WOOD: DETERIORATED DOOR
Deficiency Location/Instance	Stair G/1 - Exit 9 Vestibule
Deficiency Quantity	1
Quantity Uom	EACH
Potential Action	MAINTENANCE
Urgency of Action	PRIORITY 3
Purpose of Action	LEVEL 2
Deficiency Photo1	
	Stair G/1 - Exit 9 Vestibule
Violations	No violations recorded.
Partition	Inspected
Condition	2 - Between Good and Fair
Deficiency	GLASS PANEL: DAMAGED/DETERIORATED
Deficiency Location/Instance	Stairs CD/2, EF/2
Deficiency Quantity	10
Quantity Uom	S.F.
Potential Action	REPLACE
Urgency of Action	PRIORITY 3
Purpose of Action	LEVEL 2

**NYC Department of Education
Building Condition Assessment Survey 2023 - 2024**

Architectural Inspection

Q150

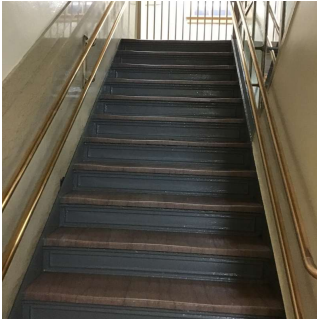
Question	Response
INTERIOR	
STAIRS/RAMPS: INTERIOR	
Partition	
Deficiency Photo1	
Violations	Stair EF/2 No violations recorded.
Railings	Inspected
Condition	2 - Between Good and Fair
Deficiency	No deficiencies recorded
Stairs and Landings	Inspected
Condition	3 - Fair
Deficiency	STONE: WORN-OUT TREAD/NOSINGS
Deficiency Location/Instance	Stair EF/1
Deficiency Quantity	130
Quantity Uom	S.F.
Potential Action	REPLACE
Urgency of Action	PRIORITY 3
Purpose of Action	LEVEL 2
Deficiency Photo1	
Violations	Stair EF/1 No violations recorded.
Deficiency	TERRAZZO: CRACKS
Deficiency Location/Instance	Stair EF/1
Deficiency Quantity	10
Quantity Uom	S.F.
Potential Action	REPLACE
Urgency of Action	PRIORITY 3
Purpose of Action	LEVEL 2

**NYC Department of Education
Building Condition Assessment Survey 2023 - 2024**

Architectural Inspection

Q150

Question

Response

INTERIOR

STAIRS/RAMPS: INTERIOR

Stairs and Landings

Deficiency Photo1

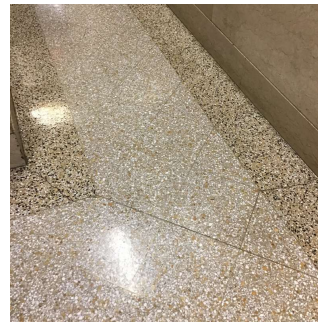

Stair EF/1

Violations

No violations recorded.

Deficiency

STONE: BROKEN/MISSING

Deficiency Location/Instance

Stairs A/1, CD/1- Exit 3/4 Vestibule, G/1 - Exit 7 Vestibule,

Deficiency Quantity

40

Quantity Uom

S.F.

Potential Action

REPLACE

Urgency of Action

PRIORITY 3

Purpose of Action

LEVEL 2

Deficiency Photo1

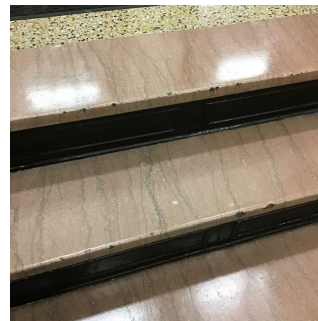

Stair G/1- Exit 7 Vestibule

Violations

No violations recorded.

Deficiency

VINYL TILES: BROKEN/DETERIORATED/MISSING TILES

Deficiency Location/Instance

Stair A/1, B/1, G/1

Deficiency Quantity

50

Quantity Uom

S.F.

Potential Action

REPLACE

Urgency of Action

PRIORITY 3

Purpose of Action

LEVEL 2

Deficiency Photo1



Stair A/1

Violations

No violations recorded.

**NYC Department of Education
Building Condition Assessment Survey 2023 - 2024**

Architectural Inspection

Q150

Question	Response
INTERIOR	
STAIRS/RAMPS: INTERIOR	
Walls	Inspected
Condition	2 - Between Good and Fair
Deficiency	STONE MOLDINGS: CRACKS/SPALLING
Deficiency Location/Instance	Stair EF/2
Deficiency Quantity	10
Quantity Uom	L.F.
Potential Action	REPLACE
Urgency of Action	PRIORITY 3
Purpose of Action	LEVEL 2
Deficiency Photo1	
Violations	Stair EF/2 No violations recorded.
Deficiency	STONE: CRACKS/SPALLING
Deficiency Location/Instance	Stair EF/1
Deficiency Quantity	20
Quantity Uom	S.F.
Potential Action	REPLACE
Urgency of Action	PRIORITY 3
Purpose of Action	LEVEL 2
Deficiency Photo1	
Violations	Stair EF/1 No violations recorded.
Deficiency	PLASTER: CRACKS/SPALLING
Deficiency Location/Instance	Stairs CD/1, G/1
Deficiency Quantity	20
Quantity Uom	S.F.
Potential Action	REPLACE
Urgency of Action	PRIORITY 3
Purpose of Action	LEVEL 2

**NYC Department of Education
Building Condition Assessment Survey 2023 - 2024**

Architectural Inspection

Q150

Question	Response
INTERIOR	
STAIRS/RAMPS: INTERIOR	
Walls	
Deficiency Photo1	
	Stair G/1
Violations	No violations recorded.
Deficiency	PLASTER: CRACKS/SPALLING - ACTIVE LEAK
Deficiency Location/Instance	Stairs G/2, H/1
Deficiency Quantity	40
Quantity Uom	S.F.
Potential Action	REPLACE
Urgency of Action	PRIORITY 5
Purpose of Action	LEVEL 2
Deficiency Photo1	
	Stair G/2
Violations	No violations recorded.
TOILET ROOMS - STAFF	Inspected
Ceiling	Inspected
Condition	2 - Between Good and Fair
Deficiency	No deficiencies recorded
Door(s)	Inspected
Condition	5 - Poor
Deficiency	WOOD: DETERIORATED DOOR
Deficiency Location/Instance	Room 257
Deficiency Quantity	1
Quantity Uom	EACH
Potential Action	MAINTENANCE
Urgency of Action	PRIORITY 3
Purpose of Action	LEVEL 2

**NYC Department of Education
Building Condition Assessment Survey 2023 - 2024**

Architectural Inspection

Q150

Question	Response
----------	----------

INTERIOR

TOILET ROOMS - STAFF

Door(s)

Deficiency Photo1



Room 257

Violations

No violations recorded.

Floor Finish

Inspected

Condition

4 - Between Fair and Poor

Deficiency

CERAMIC TILE: DETERIORATED SUBSTRATE

Deficiency Location/Instance

Room 257

Deficiency Quantity

10

Quantity Uom

S.F.

Potential Action

REPLACE

Urgency of Action

PRIORITY 3

Purpose of Action

LEVEL 2

Deficiency Photo1

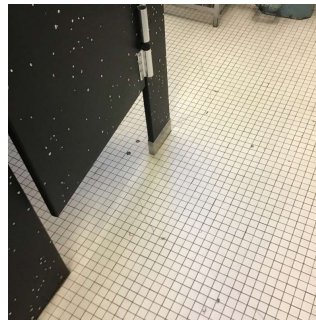

Room 257

Violations

No violations recorded.

Deficiency

CERAMIC TILE: BROKEN/MISSING TILES

Deficiency Location/Instance

Rooms 256, 357

Deficiency Quantity

20

Quantity Uom

S.F.

Potential Action

REPLACE

Urgency of Action

PRIORITY 3

Purpose of Action

LEVEL 2

Deficiency Photo1

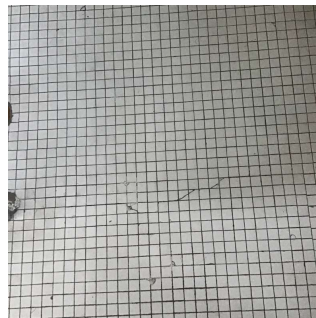

**NYC Department of Education
Building Condition Assessment Survey 2023 - 2024**

Architectural Inspection



Q150

Question	Response
INTERIOR	
TOILET ROOMS - STAFF	
Floor Finish	Inspected
	Room 357
Violations	No violations recorded.
Stalls	Inspected
Condition	2 - Between Good and Fair
Deficiency	No deficiencies recorded
Walls	Inspected
Condition	2 - Between Good and Fair
Deficiency	CERAMIC TILE: BROKEN/ MISSING
Deficiency Location/Instance	Rooms 257, 357
Deficiency Quantity	30
Quantity Uom	S.F.
Potential Action	REPLACE
Urgency of Action	PRIORITY 3
Purpose of Action	LEVEL 2
Deficiency Photo1	
	Room 357
Violations	No violations recorded.
Deficiency	PLASTER: CRACKS/SPALLING
Deficiency Location/Instance	Room 256
Deficiency Quantity	10
Quantity Uom	S.F.
Potential Action	REPLACE
Urgency of Action	PRIORITY 3
Purpose of Action	LEVEL 2
Deficiency Photo1	
	Room 257
Violations	No violations recorded.
TOILET ROOMS - STUDENTS	
	Inspected
Ceiling	Inspected
Condition	2 - Between Good and Fair
Deficiency	No deficiencies recorded

NYC Department of Education
Building Condition Assessment Survey 2023 - 2024

Architectural Inspection

Q150

Question	Response
INTERIOR	
TOILET ROOMS - STUDENTS	
Door(s)	Inspected
Condition	5 - Poor
Deficiency	METAL: DETERIORATED DOOR AND FRAME
Deficiency Location/Instance	Room 259
Deficiency Quantity	1
Quantity Uom	EACH
Potential Action	MAINTENANCE
Urgency of Action	PRIORITY 3
Purpose of Action	LEVEL 2
Deficiency Photo1	
	Room 259
Violations	No violations recorded.
Deficiency	WOOD: DETERIORATED DOOR
Deficiency Location/Instance	Room 260A
Deficiency Quantity	1
Quantity Uom	EACH
Potential Action	MAINTENANCE
Urgency of Action	PRIORITY 3
Purpose of Action	LEVEL 2
Deficiency Photo1	
	Room 260A
Violations	No violations recorded.
Floor Finish	Inspected
Condition	2 - Between Good and Fair
Deficiency	CERAMIC TILE: DETERIORATED SUBSTRATE
Deficiency Location/Instance	Room 359
Deficiency Quantity	20
Quantity Uom	S.F.
Potential Action	REPLACE
Urgency of Action	PRIORITY 3
Purpose of Action	LEVEL 2

**NYC Department of Education
Building Condition Assessment Survey 2023 - 2024**

Architectural Inspection

Q150

Question	Response
INTERIOR	
TOILET ROOMS - STUDENTS	
Floor Finish	
Deficiency Photo1	
Violations	Room 359 No violations recorded.
Deficiency	CERAMIC TILE: BROKEN/MISSING TILES
Deficiency Location/Instance	Rooms 259, 260A, Girls- 3rd Floor
Deficiency Quantity	30
Quantity Uom	S.F.
Potential Action	REPLACE
Urgency of Action	PRIORITY 3
Purpose of Action	LEVEL 2
Deficiency Photo1	
Violations	Girls- 3rd Floor No violations recorded.
Stalls	Inspected
Condition	2 - Between Good and Fair
Deficiency	No deficiencies recorded
Walls	Inspected
Condition	2 - Between Good and Fair
Deficiency	GYPSUM BOARD: DETERIORATED
Deficiency Location/Instance	Boys - 3rd Floor, Girls- 3rd Floor,
Deficiency Quantity	20
Quantity Uom	S.F.
Potential Action	REPLACE
Urgency of Action	PRIORITY 3
Purpose of Action	LEVEL 2

**NYC Department of Education
Building Condition Assessment Survey 2023 - 2024**

Architectural Inspection

Q150

Question

Response

INTERIOR

TOILET ROOMS - STUDENTS

Walls

Deficiency Photo1



Boys - 3rd Floor

No violations recorded.

Violations

Deficiency

PLASTER: CRACKS/SPALLING

Deficiency Location/Instance

Rooms 158, 160

Deficiency Quantity

30

Quantity Uom

S.F.

Potential Action

REPLACE

Urgency of Action

PRIORITY 3

Purpose of Action

LEVEL 2

Deficiency Photo1

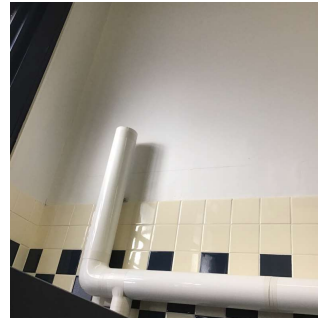

Room 160

No violations recorded.

Violations

Deficiency

CERAMIC TILE: BROKEN/ MISSING

Deficiency Location/Instance

Room 359

Deficiency Quantity

10

Quantity Uom

S.F.

Potential Action

REPLACE

Urgency of Action

PRIORITY 3

Purpose of Action

LEVEL 2

Deficiency Photo1

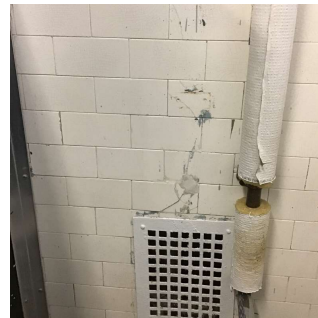

Room 359

No violations recorded.

Violations

NYC Department of Education
Building Condition Assessment Survey 2023 - 2024

Architectural Inspection

Q150

Question	Response
LIFE SAFETY	Inspected
F.D. HOLDING AREA	Does not Exist
STEEL STAIRS	Does not Exist
SITE	Inspected
CONTAINERIZATION	Does not Exist
Drainage System for Asphalt	Inspected
Catch Basins/Manhole - Surrounded by asphalt	Inspected
Condition	2 - Between Good and Fair
Deficiency	No deficiencies recorded
Culverts - Asphalt Covering	Does not Exist
Drainage System for Concrete	Inspected
Catch Basins/Manhole - Surrounded by concrete	Inspected
Condition	2 - Between Good and Fair
Deficiency	No deficiencies recorded
Culverts - Concrete Covering	Does not Exist
Drainage System for Soil	Does not Exist
DRINKING FOUNTAINS	Does not Exist
FENCES	Inaccessible
IRRIGATION SYSTEM	Does not Exist
PAVING	Inspected
Student Non-Use	Inspected
Gravel Exists?	No
Asphalt	Does not Exist
Concrete	Inspected
Condition	3 - Fair
Deficiency	DAMAGED/DETERIORATED/MISSING SECTIONS
Deficiency Location/Instance	40th Street
Deficiency Quantity	125
Quantity Uom	S.F.
Potential Action	REPLACE
Urgency of Action	PRIORITY 3
Purpose of Action	LEVEL 2
Deficiency Photo1	
Violations	40th Street No violations recorded.
Pavers	Inaccessible
Student Use	Inspected
Gravel Exists?	No
Asphalt	Inspected
Condition	4 - Between Fair and Poor
Deficiency	CRACKS - MAJOR

NYC Department of Education
Building Condition Assessment Survey 2023 - 2024

Architectural Inspection



Q150

Question	Response
SITE	
PAVING	
Student Use	
Asphalt	
Deficiency Location/Instance	Near 40th Street, 41st Street, Center,
Deficiency Quantity	1,500
Quantity Uom	S.F.
Potential Action	REPLACE
Urgency of Action	PRIORITY 3
Purpose of Action	LEVEL 2
Deficiency Photo1	
Violations	Near 41st Street No violations recorded.
Concrete	Does not Exist
Pavers	Does not Exist
Site Sidewalks & Walkways	Inspected
Asphalt	Inspected
Condition	2 - Between Good and Fair
Deficiency	CRACKS - MAJOR
Deficiency Location/Instance	Near Exits 9, 13
Deficiency Quantity	30
Quantity Uom	S.F.
Potential Action	REPLACE
Urgency of Action	PRIORITY 3
Purpose of Action	LEVEL 2
Deficiency Photo1	
Violations	Near Exit 13 No violations recorded.
Concrete	Inspected
Condition	3 - Fair
Deficiency	DAMAGED/DETERIORATED/MISSING SECTIONS
Deficiency Location/Instance	Near Exit 2, 40th Street.
Deficiency Quantity	150
Quantity Uom	S.F.

**NYC Department of Education
Building Condition Assessment Survey 2023 - 2024**

Architectural Inspection



Q150

Question	Response
SITE	
PAVING	
Site Sidewalks & Walkways	
Concrete	
Potential Action	REPLACE
Urgency of Action	PRIORITY 3
Purpose of Action	LEVEL 2
Deficiency Photo1	
	Near Exit 2
Violations	No violations recorded.
Pavers	Does not Exist
DOT Sidewalk	Inspected
Asphalt	Does not Exist
Concrete	Inspected
Condition	4 - Between Fair and Poor
Deficiency	HEAVING
Deficiency Location/Instance	40th Street
Deficiency Quantity	100
Quantity Uom	S.F.
Potential Action	REPLACE
Urgency of Action	PRIORITY 5
Purpose of Action	LEVEL 6
Deficiency Photo1	
	40th Street
Violations	No violations recorded.
Deficiency	DAMAGED/DETERIORATED/MISSING SECTIONS
Deficiency Location/Instance	40th Street, 41st Street, 43rd Avenue
Deficiency Quantity	425
Quantity Uom	S.F.
Potential Action	REPLACE
Urgency of Action	PRIORITY 3
Purpose of Action	LEVEL 2

**NYC Department of Education
Building Condition Assessment Survey 2023 - 2024**

Architectural Inspection

Q150

Question	Response
SITE	
PAVING	
DOT Sidewalk	
Concrete	
Deficiency Photo1	
Violations	43rd Avenue No violations recorded.
Deficiency	DAMAGED CURBS
Deficiency Location/Instance	40th Street, 41st Street, 43rd Avenue
Deficiency Quantity	60
Quantity Uom	L.F.
Potential Action	REPLACE
Urgency of Action	PRIORITY 3
Purpose of Action	LEVEL 2
Deficiency Photo1	
Violations	43rd Avenue No violations recorded.
Pavers	Does not Exist
PLAYGROUNDS	Inspected
Instance on Schoolyard	Inspected
Benches	
Instance on Schoolyard	Does not Exist
Fence	
Instance on Schoolyard	Does not Exist
Pavement	
Instance on Schoolyard	Does not Exist
Play Equipment	
Instance on Schoolyard	Inspected
Condition	5 - Poor
Deficiency	BROKEN/DETERIORATED/MISSING
Deficiency Location/Instance	Near Center
Deficiency Quantity	1
Quantity Uom	EACH

**NYC Department of Education
Building Condition Assessment Survey 2023 - 2024**

Architectural Inspection

Q150

Question	Response
SITE	
PLAYGROUNDS	
Play Equipment	
Potential Action	REPLACE
Urgency of Action	PRIORITY 3
Purpose of Action	LEVEL 2
Deficiency Photo1	
	Near Center
Violations	No violations recorded.
Safety Surfacing	
Instance on Schoolyard	Inspected
Condition	3 - Fair
Deficiency	DETERIORATED/MISSING
Deficiency Location/Instance	Near Center, Borders, climb Area, Stairs.
Deficiency Quantity	200
Quantity Uom	S.F.
Potential Action	MAINTENANCE
Urgency of Action	PRIORITY 3
Purpose of Action	LEVEL 2
Deficiency Photo1	
	Near Center
Violations	No violations recorded.
Unpaved Area	
Instance on Schoolyard	Does not Exist
PLAYING SURFACE	Does not Exist
RETAINING WALLS	Inaccessible
SEATING	Inspected
Benches	Inspected
Concrete	Does not Exist
Metal/Wood/Plastic	Inspected
Condition	2 - Between Good and Fair
Deficiency	No deficiencies recorded
Bleachers	Does not Exist

**NYC Department of Education
Building Condition Assessment Survey 2023 - 2024**

Architectural Inspection

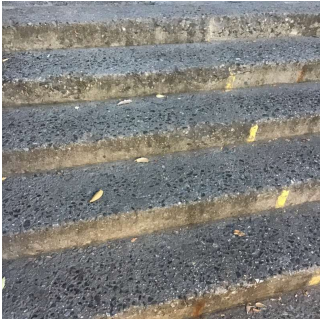

Q150

Question	Response
SITE	
SITE WALLS (NOT RETAINING WALLS)	Does not Exist
STAIRS/RAMPS: EXTERIOR	Inspected
Railings	Inspected
Condition	2 - Between Good and Fair
Deficiency	No deficiencies recorded
Site Cheek/flank Walls	Inspected
Condition	2 - Between Good and Fair
Deficiency	CAST IN PLACE CONCRETE: CRACKS/SPALLING - MAJOR
Deficiency Location/Instance	Near Exit 9
Deficiency Quantity	10
Quantity Uom	S.F.
Potential Action	REPLACE
Urgency of Action	PRIORITY 3
Purpose of Action	LEVEL 2
Deficiency Photo1	
	Near Exit 9
Violations	No violations recorded.
Stairs/ramps	Inspected
Condition	3 - Fair
Deficiency	CAST IN PLACE CONCRETE: CRACKS/SPALLING - MAJOR
Deficiency Location/Instance	Near Exit 9
Deficiency Quantity	50
Quantity Uom	S.F.
Potential Action	REPLACE
Urgency of Action	PRIORITY 3
Purpose of Action	LEVEL 2
Deficiency Photo1	
	Near Exit 9
Violations	No violations recorded.
ARTWORK	Inspected
Instance	Interior - Auditorium - 21006

**NYC Department of Education
Building Condition Assessment Survey 2023 - 2024**

Architectural Inspection

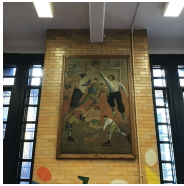
Q150

Question	Response
ARTWORK	
Instance Photo	
	Auditorium
Instance ID	21006
Artwork exist at stated location?	Yes
Instance	Interior - Cafeteria - 31300
Instance Photo	
	Cafeteria
Instance ID	31300
Artwork exist at stated location?	Yes
Instance	Interior - Auditorium - 11109
Instance Photo	
	Auditorium
Instance ID	11109
Artwork exist at stated location?	Yes