

**NYC Department of Education**  
**Building Condition Assessment Survey 2023 - 2024**

Architectural Inspection

Q102

**Asset:** P.S./I.S. 102 - QUEENS, 55-24 VAN HORN STREET, New York, 11373

Inspection Id	Inspection Type	Time In	Last Edited
SA : Q102	Architectural - Senior	2024-02-14 7:52 AM	2024-06-06 3:48 PM
AA : Q102	Architectural - Associate	2024-02-14 8:56 AM	2024-04-11 1:50 PM

Asset Data

Question	Answer
Was the building fully accessible for inspection	Yes
Building Square Footage	123,000
Comments on the Area (for Athletic Field, Playing Surfaces, Leased Spaces)	None
Comments on the Stories (Floors) plus Basements	4+B+PH
Comments on the Number of Classrooms	57
Comments on the Year Built	1923
Student Population	1,200
Staff Population	130
Weather	Fair
Principal(s) Information	
Principal Name	Catherine Weinstein
Organization	P.S./I.S 102 - Queens
Did you meet with this Principal?	Yes
Did this Principal provide feedback?	Yes
Summary of Principal's Feedback	The Principal's comment is as follows: The BMS is defective.
Custodian	Was not present
Fireman	Richard Acosta
Facade Photo	



Van Horn Street - West View

**NYC Department of Education  
Building Condition Assessment Survey 2023 - 2024**

Architectural Inspection

Q102

Main Entrance Photo



Facade A - Van Horn Street

Roof Photo



Roof 6 - Southeast View

Have any Systems/Major Building Components been upgraded?

Yes

Systems: Columns/Beams - repairs

Year: 2023

Systems: Roofing (Modified Bitumen), Stairs and Ramps, Exterior Guards, Windows (Original Building) - replacement; Chimney, Coping, Doors/Frames, Transoms, Exterior Walls, Parapets, Penthouse, Foundation Walls - repairs

Year: 2022

Systems: Roofing (Built-up) - replacement

Year: 2009

Have there been any Building Additions?

Yes

Comments on Building Additions

2009 (+63,000 SF)

Tandem Schools?

No

Leased Space?

No

**Priority Condition**

Priority Condition Exist Last Year?	Priority Category	Condition Description	Component Affected	Location Description	Person(s) Notified	Person(s) Title	PhotoImage
-------------------------------------	-------------------	-----------------------	--------------------	----------------------	--------------------	-----------------	------------

NYC Department of Education

Building Condition Assessment Survey 2023 - 2024

Architectural Inspection

Q102

No	Tripping Hazard	Severely damaged vinyl tile floor is a potential tripping hazard.	INTERIOR   CLASSROOMS /CORRIDORS/ ADMIN SPACES   Floor Finish	Room 338	Richard Acosta	Fireman
----	-----------------	---	---	----------	----------------	---------



Structural Engineer Required

Structural Condition Type	Condition Description	Component Affected	Location Description	Person(s) Notified	Person(s) Title	PhotoImage
No condition recorded						

Programmatic Accessibility

Programmatic Accessibility Status Question	Response
Is the primary or secondary entrance on an accessible route?	Yes
Is the building a multi-story building?	Yes
Are all floors of the building accessible through compliant means?	Yes
Accessible classrooms exists on each floor?	Yes
Boys and Girls or Unisex accessible toilets exist on at least every other floor?	Yes
If the following spaces exist, are they ALL accessible? Art Room, Auditorium, Cafeteria, Computer, Gymnasiums, Library, Multipurpose Room, Science Labs	Yes

Physical Breakdown Structure	Exists	Required	Complies	Deficiency	Assistive Fire Listening System	Fire Alarm Strobe
------------------------------	--------	----------	----------	------------	---------------------------------	-------------------

PROGRAMMATIC ACCESSIBILITY

Exterior Routes

Exterior Entrances & Exits			Yes			
Exterior H/C Lifts	No	No				
Exterior Ramps and Railings	No	No				

Interior Routes

Corridor and Lobby H/C Lifts	No	No				
Interior Corridor Doors and Hardware	Yes		Yes			
Interior Corridors and Lobbies			Yes			
Interior Elevators	Yes		Yes			
Interior Lobby Doors and Hardware			Yes			
Interior Ramps	No					

Rooms & Spaces

Art Rooms	Rooms 322, 326	Yes		Yes			
Auditorium	2nd Floor	Yes	No	No Stage Access	No	Yes	
Cafeteria	Basement	Yes		Yes	FM System	Yes	
Classrooms	1st - 4th Floors	Yes		Yes			
Computer Rooms	Room 325	Yes		Yes			
Gymnasium	Basement	Yes		Yes	FM System	Yes	
Library	Room 133	Yes		Yes			
Main Office	Room 150	Yes		Yes			
Multi-purpose Room	1st Floor	Yes		Yes	FM System	Yes	
Nurse's Room	Room 112	Yes		Yes			

**NYC Department of Education**  
**Building Condition Assessment Survey 2023 - 2024**

Architectural Inspection

Q102

Physical Breakdown Structure	Exists	Required	Complies	Deficiency	Assistive Listening System	Fire Alarm Strobe
<b>Rooms &amp; Spaces</b>						
Pool	No					
Science Lab	Rooms 202, 424, 428	Yes	Yes			
Toilet Rooms (Boys)	Basement, 1st - 4th Floors	Yes	Yes			
Toilet Rooms (Girls)	Basement, 1st - 4th Floors	Yes	Yes			
Toilet Rooms (Staff)	Basement, 1st - 4th Floors	Yes	Yes			

Building Template

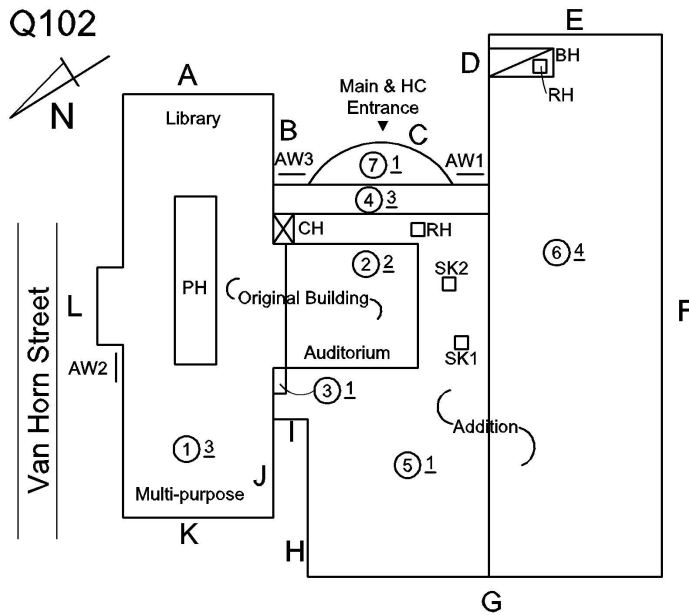

Inspection

Question	Response
<b>Architectural</b>	
<b>EXTERIOR</b>	Inspected
<b>AREAWAY</b>	Inspected
Instance on AW1-AW3	Inspected
Instance Condition	2 - Between Good and Fair
Instance Quantity	3
Instance Quantity Uom	EACH
Deficiency	AREAWAY WALLS: CRACKS AND SPALLING
Roof Plan reference	Q102
Deficiency Quantity	20
Quantity Uom	S.F.

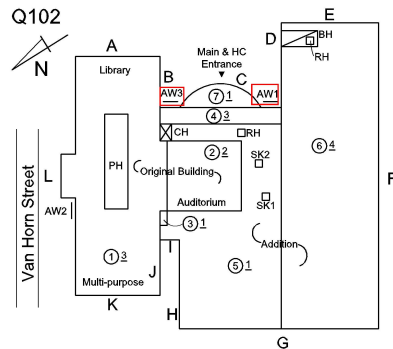



**NYC Department of Education  
Building Condition Assessment Survey 2023 - 2024**

Architectural Inspection

Q102

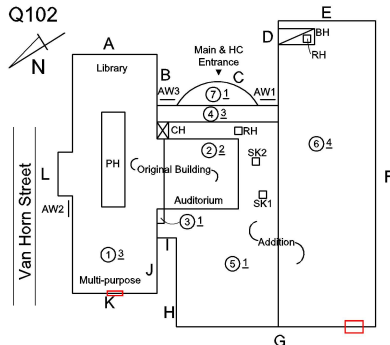
Question	Response
<b>EXTERIOR</b>	
<b>AREAWAY</b>	
Potential Action	REPAIR
Urgency of Action	PRIORITY 3
Purpose of Action	LEVEL 2
Deficiency Photo1	
	AW3
Violations	No violations recorded.
<b>AWNINGS AND CANOPIES</b>	
	Inspected
Condition	2 - Between Good and Fair
Deficiency	No deficiencies recorded
<b>CHIMNEY</b>	
	Inspected
Material Type(s)	Masonry, Metal
Condition	2 - Between Good and Fair
Deficiency	No deficiencies recorded
<b>COPING</b>	
	Inspected
Condition	2 - Between Good and Fair
Deficiency	No deficiencies recorded
<b>CORNICE</b>	
	Inspected
Condition	2 - Between Good and Fair
Deficiency	No deficiencies recorded
<b>DOORS</b>	
	Inspected
<b>DOORS AND FRAMES</b>	
	Inspected
Condition	4 - Between Fair and Poor
Deficiency	METAL: DETERIORATED DOOR AND FRAME - MINOR DETERIORATION
Roof Plan reference	Q102
	
Deficiency Quantity	4
Quantity Uom	EACH
Potential Action	MAINTENANCE
Urgency of Action	PRIORITY 3
Purpose of Action	LEVEL 2
Deficiency Photo1	No photo recorded
Violations	No violations recorded.

**NYC Department of Education  
Building Condition Assessment Survey 2023 - 2024**

Architectural Inspection

Q102

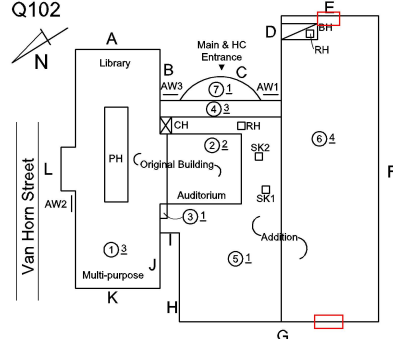
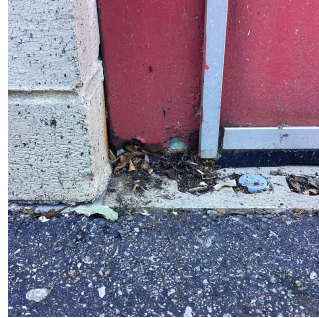
Question	Response
<b>EXTERIOR</b>	
<b>DOORS</b>	
<b>DOORS AND FRAMES</b>	
Deficiency	METAL: DETERIORATED DOOR AND FRAME - MAJOR DETERIORATION
Roof Plan reference	<p>Q102</p>  <p>The diagram is a floor plan of a building with several rooms labeled: Library, PH, Multi-purpose, Auditorium, and Main &amp; HC Entrance. It also shows structural elements like walls (AW1, AW2, AW3), columns (CH, RH), and skylights (SK1, SK2). A red box on the right side of the plan, near the Main &amp; HC Entrance, indicates the location of the deficiency on Facade G.</p>
Deficiency Quantity	4
Quantity Uom	EACH
Potential Action	REPLACE
Urgency of Action	PRIORITY 4
Purpose of Action	LEVEL 2
Deficiency Photo1	 <p>The photograph shows a close-up of a red-painted metal door frame. At the bottom of the frame, there is significant rust, peeling paint, and debris, indicating severe metal deterioration.</p>
Violations	Facade G No violations recorded.
<b>DOOR HARDWARE</b>	Inspected
Condition	2 - Between Good and Fair
Deficiency	No deficiencies recorded
<b>LINTELS</b>	Inspected
Condition	2 - Between Good and Fair
Deficiency	No deficiencies recorded
<b>TRANSOM/SIDE LIGHT</b>	Inspected
Condition	2 - Between Good and Fair
Deficiency	No deficiencies recorded
<b>EXTERIOR WALLS</b>	Inspected
Material Type(s)	Masonry, Steel, Concrete
Replacement Quantity	62,500
Replacement Uom	S.F.
Instance on All Facades	Inspected
Instance Condition	3 - Fair
Instance Quantity	62,500
Instance Quantity Uom	S.F.
Deficiency	BRICK: MAJOR / THRU CRACKS

**Question**

**Response**

**EXTERIOR**

**EXTERIOR WALLS**

Roof Plan reference

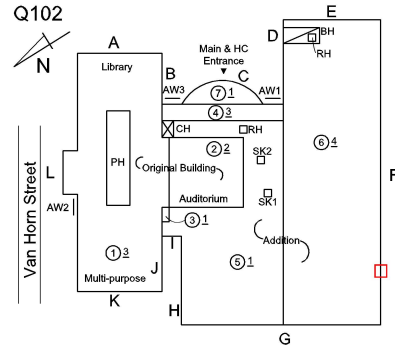

Elevation

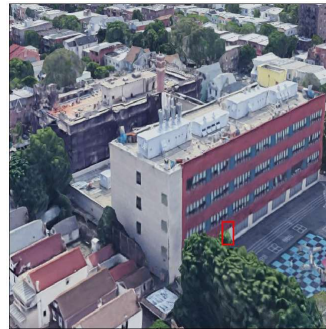

Deficiency Quantity

10

Quantity Uom

S.F.

Potential Action

REMOVE AND REBUILD

Urgency of Action

PRIORITY 4

Purpose of Action

LEVEL 2

Deficiency Photo1



Facade F

Violations

No violations recorded.

Deficiency

STONE: DETERIORATED JOINTS

Roof Plan reference

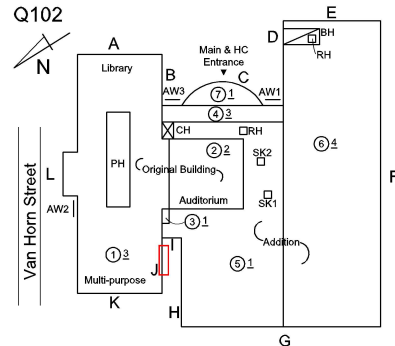

**NYC Department of Education  
Building Condition Assessment Survey 2023 - 2024**

Architectural Inspection

Q102

**Question**

**Response**

**EXTERIOR**

**EXTERIOR WALLS**

Elevation

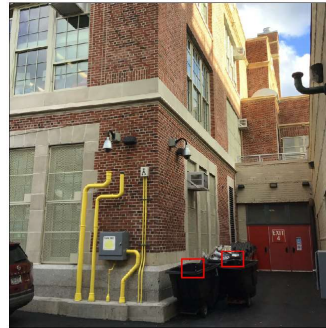

Deficiency Quantity

20

Quantity Uom

L.F.

Potential Action

REPOINT

Urgency of Action

PRIORITY 4

Purpose of Action

LEVEL 2

Deficiency Photo1

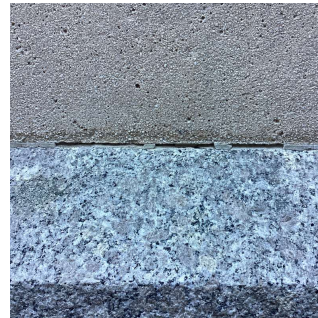

Facade J

Violations

No violations recorded.

Deficiency

BRICK: EFFLORESCENCE

Roof Plan reference

Q102

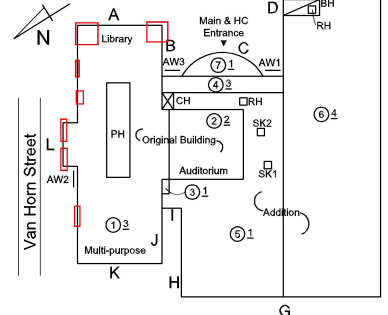

Elevation



Deficiency Quantity

80

Quantity Uom

S.F.

Potential Action

MAINTENANCE

**NYC Department of Education  
Building Condition Assessment Survey 2023 - 2024**

Architectural Inspection

Q102

**Question**

**Response**

**EXTERIOR**

**EXTERIOR WALLS**

Urgency of Action  
Purpose of Action  
Deficiency Photo1  
Violations

PRIORITY 1  
LEVEL 1  
No photo recorded  
No violations recorded.

Deficiency

CAST IN PLACE / PRE-CAST CONCRETE: MINOR  
CRACKS/SPALLING

Roof Plan reference

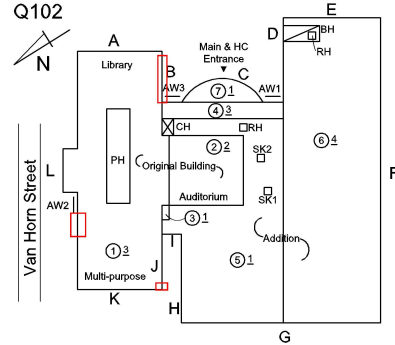

Elevation

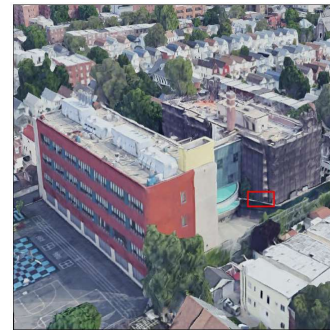

Deficiency Quantity  
Quantity Uom  
Potential Action  
Urgency of Action  
Purpose of Action  
Deficiency Photo1

30  
S.F.  
REPAIR  
PRIORITY 3  
LEVEL 2



Facade B

No violations recorded.

Deficiency

STONE: CHIPPED/SPALLED/BROKEN PIECES - MINOR

**NYC Department of Education  
Building Condition Assessment Survey 2023 - 2024**

Architectural Inspection

**Q102**

**Question**

**Response**

**EXTERIOR**

**EXTERIOR WALLS**

Roof Plan reference

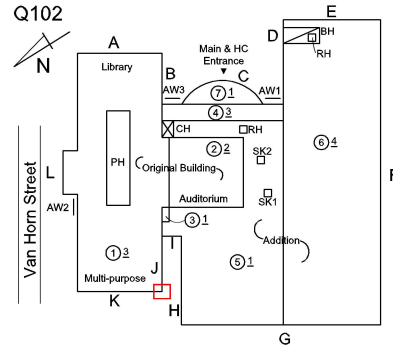

Elevation

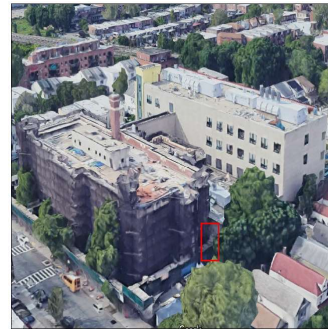

Deficiency Quantity

10

Quantity Uom

S.F.

Potential Action

REPAIR

Urgency of Action

PRIORITY 3

Purpose of Action

LEVEL 2

Deficiency Photo1

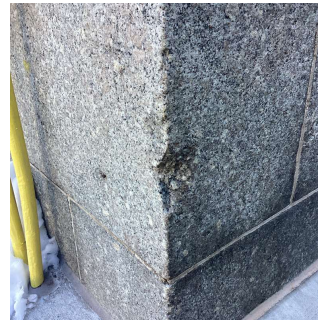

Facade K

No violations recorded.

Violations

Deficiency

**METAL/GLASS CURT WALL: BROKEN GLASS**

Roof Plan reference

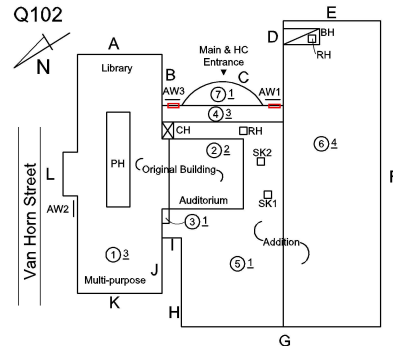



**NYC Department of Education  
Building Condition Assessment Survey 2023 - 2024**

Architectural Inspection

Q102

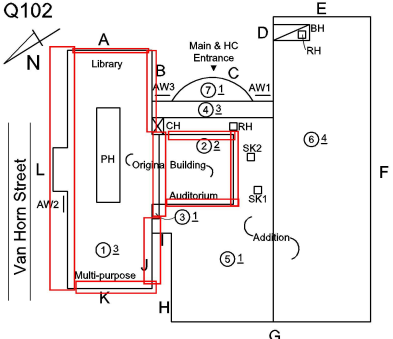
Question	Response
<b>EXTERIOR</b>	
<b>EXTERIOR WALLS</b>	
Elevation	
Deficiency Quantity	60
Quantity Uom	S.F.
Potential Action	REPLACE
Urgency of Action	PRIORITY 3
Purpose of Action	LEVEL 2
Deficiency Photo1	No photo recorded
Violations	No violations recorded.
<b>EXTERIOR SOFFITS</b>	Does not Exist
<b>LOADING DOCK</b>	Does not Exist
<b>LOUVER</b>	Inspected
Condition	2 - Between Good and Fair
Deficiency	No deficiencies recorded
<b>PARAPETS</b>	Inspected
Material Type(s)	Masonry, Concrete
Replacement Quantity	12,700
Replacement Uom	C.F.
Instance on All Facades	Inspected
Instance Condition	3 - Fair
Instance Quantity	12,700
Instance Quantity Uom	C.F.
Deficiency	<b>BRICK: EFFLORESCENCE</b>
Roof Plan reference	
Deficiency Quantity	200
Quantity Uom	S.F.
Potential Action	MAINTENANCE
Urgency of Action	PRIORITY 1
Purpose of Action	LEVEL 1
Deficiency Photo1	No photo recorded
Violations	No violations recorded.

**NYC Department of Education  
Building Condition Assessment Survey 2023 - 2024**

Architectural Inspection

**Q102**

**Question**

**Response**

**EXTERIOR**

**PARAPETS**

Deficiency

Roof Plan reference

CONCRETE: MINOR CRACKS, SPALLING

Q102

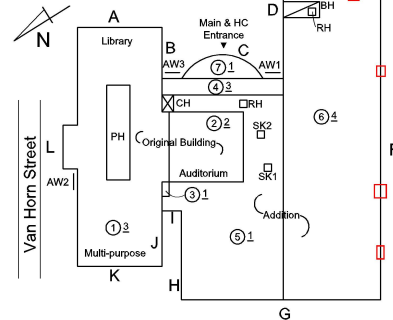

Deficiency Quantity

40

Quantity Uom

S.F.

Potential Action

REPAIR

Urgency of Action

PRIORITY 3

Purpose of Action

LEVEL 2

Deficiency Photo1



Roof 6

Violations

No violations recorded.

**PLAZA DECK**

Does not Exist

**ROOF**

Inspected

**Roofing**

Inspected

Replacement Quantity

35,600

Replacement Uom

S.F.

**ROOF HATCH/SMOKE HATCH**

Inspected

Condition

2 - Between Good and Fair

Deficiency

No deficiencies recorded

**LEADERS, GUTTERS, DOWNSPOUTS, SCUPPERS**

Inspected

Condition

2 - Between Good and Fair

Deficiency

No deficiencies recorded

**ROOF BARRIER/FENCE**

Inspected

Condition

3 - Fair

Deficiency

RAILINGS/PANELS: DETERIORATED, MAJOR RUSTING

**NYC Department of Education  
Building Condition Assessment Survey 2023 - 2024**

Architectural Inspection

Q102

**Question**

**Response**

**EXTERIOR**

**ROOF**

**Roofing**

**ROOF BARRIER/FENCE**

Roof Plan reference

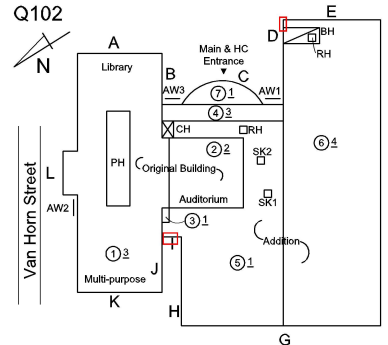

Deficiency Quantity  
Quantity Uom  
Potential Action  
Urgency of Action  
Purpose of Action  
Deficiency Photo1

40  
S.F.  
REPLACE  
PRIORITY 4  
LEVEL 2

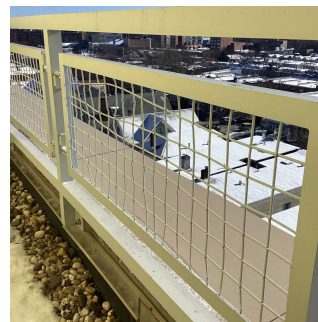

Roof 6 - Facade D

No violations recorded.

Violations

**ROOF CAGE**

Does not Exist

**ROOFING**

Inspected

Instance on Metal: Roof 7

Inspected

Instance Condition

1 - Good

Instance Photo

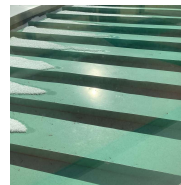

Roof 7

Instance Quantity

600

Instance Quantity Uom

S.F.

Does the roof have major mechanical equipment sitting on

No

Dunnage Steel less than 18" above the Roofing?

No

Does this roof instance have a Sustainable Roof System?

No

Do solar panels exist on these roofs?

No

Is/Are the roof(s) suitable for Solar Panel installation?

No

Installation Year

2009

Source of Installation

Custodial Staff



Deficiency

No deficiencies recorded

**NYC Department of Education**  
**Building Condition Assessment Survey 2023 - 2024**

Architectural Inspection

Q102

Question	Response
<b>EXTERIOR</b>	
<b>ROOF</b>	
<b>Roofing</b>	
<b>ROOFING</b>	
Instance on Modified Bitumen: Roofs 1, 2	Inspected
Instance Condition	1 - Good
Instance Photo	
	Roof 1
Instance Quantity	8,900
Instance Quantity Uom	S.F.
Does the roof have major mechanical equipment sitting on Dunnage Steel less than 18" above the Roofing?	No
Does this roof instance have a Sustainable Roof System?	Yes
Sustainable Roof Type	White Roof
Sustainable Roof Location (Roof Number)	Roofs 1, 2
Do solar panels exist on these roofs?	No
Is/Are the roof(s) suitable for Solar Panel installation?	No
Installation Year	2022
Source of Installation	Custodial Staff
Deficiency	No deficiencies recorded
Instance on IRMA: Roofs 4, 5, 6	Inspected
Instance Condition	3 - Fair
Instance Photo	
	Roof 6
Instance Quantity	26,000
Instance Quantity Uom	S.F.
Does the roof have major mechanical equipment sitting on Dunnage Steel less than 18" above the Roofing?	No
Does this roof instance have a Sustainable Roof System?	No
Do solar panels exist on these roofs?	No
Is/Are the roof(s) suitable for Solar Panel installation?	No
Installation Year	2009
Source of Installation	Custodial Staff
Deficiency	IRMA: ROOFING: MAJOR ACTIVE ROOF LEAKS IN INSTRUCTIONAL SPACE

**NYC Department of Education  
Building Condition Assessment Survey 2023 - 2024**

Architectural Inspection

**Q102**

**Question**

**Response**

**EXTERIOR**

**ROOF**

**Roofing**

**ROOFING**

Roof Plan reference

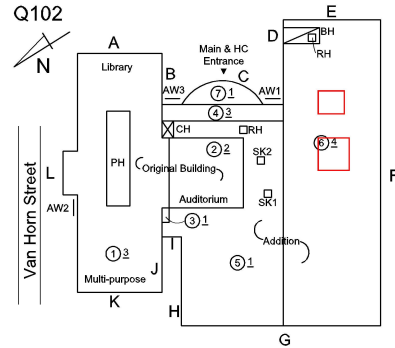

Deficiency Quantity

200

Quantity Uom

S.F.

Potential Action

REPLACE ROOFING WITHOUT MAJOR EQUIPMENT REMOVAL

Urgency of Action

PRIORITY 5

Purpose of Action

LEVEL 2

Deficiency Photo1



Roof 6 - Corridor near Room 403 (shown), Corridor near Room 408 (similar)

Violations

No violations recorded.

Instance on Built-Up: Roof 3

Inspected

Instance Condition

5 - Poor

Instance Photo

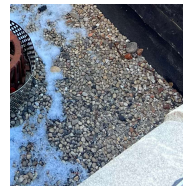

Roof 3

Instance Quantity

100

Instance Quantity Uom

S.F.

Does the roof have major mechanical equipment sitting on

No

Dunnage Steel less than 18" above the Roofing?

No

Does this roof instance have a Sustainable Roof System?

No

Do solar panels exist on these roofs?

No

Is/Are the roof(s) suitable for Solar Panel installation?

No

Installation Year

2009

Source of Installation

Inspector Estimate

Deficiency

BUILT-UP: FLASHING: CAP FLASHING MISSING

**NYC Department of Education  
Building Condition Assessment Survey 2023 - 2024**

Architectural Inspection

Q102



Question	Response
<b>EXTERIOR</b>	
<b>ROOF</b>	
<b>Roofing</b>	
<b>ROOFING</b>	
Roof Plan reference	
Deficiency Quantity	10
Quantity Uom	L.F.
Potential Action	INSTALL NEW
Urgency of Action	PRIORITY 4
Purpose of Action	LEVEL 2
Deficiency Photo1	
Violations	No violations recorded.
<b>ROOFING DRAINS</b>	Inspected
Condition	2 - Between Good and Fair
Deficiency	No deficiencies recorded
<b>Specialties</b>	Inspected
<b>BULKHEAD/PENTHOUSE</b>	Inspected
Condition	3 - Fair
Deficiency	BULKHEAD/PENTHOUSE WALLS/INTERIOR: CMU CRACKS/SPALLING
Roof Plan reference	
Deficiency Quantity	20
Quantity Uom	S.F.
Potential Action	REPLACE



**NYC Department of Education  
Building Condition Assessment Survey 2023 - 2024**

Architectural Inspection

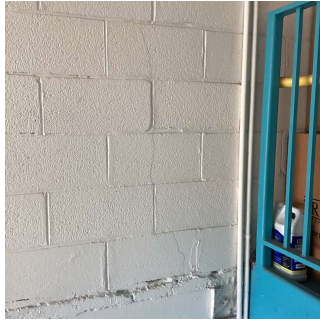
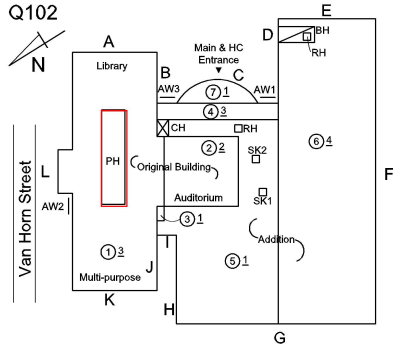

Q102

Question	Response
<b>EXTERIOR</b>	
<b>ROOF</b>	
<b>Specialties</b>	
<b>BULKHEAD/PENTHOUSE</b>	
Urgency of Action	PRIORITY 3
Purpose of Action	LEVEL 2
Deficiency Photo1	
Violations	BH No violations recorded.
Deficiency	BULKHEAD/PENTHOUSE WALLS/INTERIOR: BRICK CRACKS/SPALLING
Roof Plan reference	Q102 
Deficiency Quantity	20
Quantity Uom	S.F.
Potential Action	REPLACE
Urgency of Action	PRIORITY 4
Purpose of Action	LEVEL 2
Deficiency Photo1	
Violations	PH No violations recorded.
<b>CUPOLA/ SPIRES/ TOWERS</b>	Does not Exist
<b>DORMER</b>	Does not Exist
<b>DUNNAGE STEEL</b>	Does not Exist
<b>SKYLIGHT/ROOF VENT</b>	Inspected
Material Type(s)	Glass

**NYC Department of Education  
Building Condition Assessment Survey 2023 - 2024**

Architectural Inspection

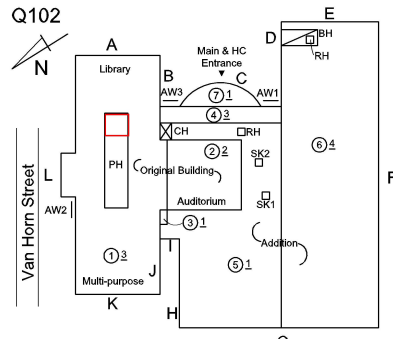
Q102

Question	Response
<b>EXTERIOR</b>	
<b>ROOF</b>	
<b>Specialties</b>	
<b>SKYLIGHT/ROOF VENT</b>	Inspected
Condition	2 - Between Good and Fair
Deficiency	No deficiencies recorded
<b>ROOF/GRAVITY TANK</b>	Inspected
Condition	3 - Fair
Deficiency	TANK: NOT IN USE - MINOR DETERIORATION
Roof Plan reference	<p>Q102</p> 
Deficiency Quantity	1
Quantity Uom	EACH
Potential Action	NO ACTION
Urgency of Action	PRIORITY 1
Purpose of Action	LEVEL 1
Deficiency Photo1	
PH	PH
Violations	No violations recorded.
<b>STAIRS/RAMPS: EXTERIOR</b>	Inspected
<b>BUILDING CHEEK/FLANK WALLS</b>	Inspected
Condition	1 - Good
Deficiency	No deficiencies recorded
<b>RAILINGS</b>	Inspected
Condition	1 - Good
Deficiency	No deficiencies recorded
<b>STAIRS/RAMPS</b>	Inspected
Condition	1 - Good
Deficiency	No deficiencies recorded
<b>WINDOWS</b>	Inspected
Replacement Quantity	10,400
Replacement Uom	S.F.
<b>EXTERIOR GUARDS</b>	Inspected
Condition	2 - Between Good and Fair

**NYC Department of Education  
Building Condition Assessment Survey 2023 - 2024**

Architectural Inspection

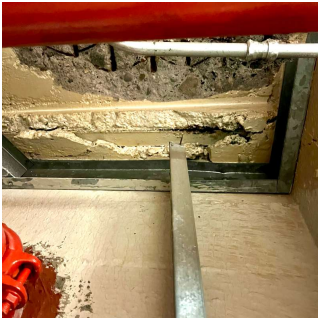

Q102

Question	Response
<b>EXTERIOR</b>	
<b>WINDOWS</b>	
<b>EXTERIOR GUARDS</b>	Inspected
Deficiency	No deficiencies recorded
<b>LINTELS</b>	Inspected
Condition	2 - Between Good and Fair
Deficiency	No deficiencies recorded
<b>WINDOWS</b>	Inspected
Material Type(s)	Aluminum
Instance on Aluminum - Other: Facades D, E, F, G	Inspected
Instance Condition	2 - Between Good and Fair
Instance Quantity	5,600
Instance Quantity Uom	S.F.
Are these windows insulated	Yes
Installation Year	2009
Source of Installation	Custodial Staff
Deficiency	No deficiencies recorded
Instance on Aluminum - Double Hung: Original Building	Inspected
Instance Condition	1 - Good
Instance Quantity	4,800
Instance Quantity Uom	S.F.
Are these windows insulated	Yes
Installation Year	2022
Source of Installation	Custodial Staff
Deficiency	No deficiencies recorded
<b>INTERIOR</b>	Inspected
<b>POOLS</b>	Does not Exist
<b>STRUCTURAL</b>	Inspected
<b>COLUMNS/BEAMS/BEARING WALLS</b>	Inspected
Condition	3 - Fair
Deficiency	STEEL COLUMNS/BEAMS: DETERIORATED CONCRETE FIREPROOFING
Deficiency Location/Instance	Basement - Fire Pump Room
Deficiency Quantity	20
Quantity Uom	S.F.
Potential Action	REPLACE
Urgency of Action	PRIORITY 4
Purpose of Action	LEVEL 5
Deficiency Photo1	
	Basement - Fire Pump Room
Violations	No violations recorded.
<b>FLOOR STRUCTURE</b>	Inspected

**NYC Department of Education  
Building Condition Assessment Survey 2023 - 2024**

Architectural Inspection

Q102

Question	Response
<b>INTERIOR</b>	
<b>STRUCTURAL</b>	
<b>FLOOR STRUCTURE</b>	
Condition	4 - Between Fair and Poor
Deficiency	CONCRETE: CRACKS/SPALLED/REINFORCEMENT EXPOSED
Deficiency Location/Instance	Basement - Fire Pump Room, Gas Meter Room, Crawlspace
Deficiency Quantity	80
Quantity Uom	S.F.
Potential Action	REPAIR
Urgency of Action	PRIORITY 4
Purpose of Action	LEVEL 5
Deficiency Photo1	
Violations	Basement - Fire Pump Room No violations recorded.
Deficiency	CONCRETE: CRACKS/SPALLED/REINFORCEMENT EXPOSED
Deficiency Location/Instance	PH, Basement - Gas Meter Room
Deficiency Quantity	60
Quantity Uom	S.F.
Potential Action	REPAIR
Urgency of Action	PRIORITY 3
Purpose of Action	LEVEL 5
Deficiency Photo1	
Violations	PH No violations recorded.
Deficiency	CONCRETE SLAB ON GRADE: THRU CRACKS
Deficiency Location/Instance	Basement - Boiler Room, Crawlspace, Fire Pump Room
Deficiency Quantity	60
Quantity Uom	S.F.
Potential Action	REPLACE
Urgency of Action	PRIORITY 4
Purpose of Action	LEVEL 5

**NYC Department of Education  
Building Condition Assessment Survey 2023 - 2024**

Architectural Inspection

Q102

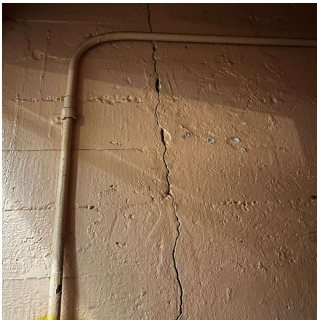
Question	Response
<b>INTERIOR</b>	
<b>STRUCTURAL</b>	
<b>FLOOR STRUCTURE</b>	
Deficiency Photo1	
Violations	Basement - Fire Pump Room No violations recorded.
<b>FOUNDATION WALLS</b>	
Material Type(s)	Inspected Concrete, Masonry
Condition	3 - Fair
Deficiency	CONCRETE: CRACKED/SPALLED/REINFORCEMENT EXPOSED
Deficiency Location/Instance	Basement - Boiler Room
Deficiency Quantity	40
Quantity Uom	S.F.
Potential Action	REPAIR
Urgency of Action	PRIORITY 4
Purpose of Action	LEVEL 5
Deficiency Photo1	
Violations	Basement - Boiler Room No violations recorded.
<b>ROOF STRUCTURE</b>	
Condition	Inspected 3 - Fair
Deficiency	CONCRETE COLUMNS AND BEAMS: CRACKED/SPALLED/REINFORCEMENT EXPOSED
Deficiency Location/Instance	PH
Deficiency Quantity	10
Quantity Uom	S.F.
Potential Action	REPAIR
Urgency of Action	PRIORITY 3
Purpose of Action	LEVEL 5

**NYC Department of Education  
Building Condition Assessment Survey 2023 - 2024**

Architectural Inspection

Q102

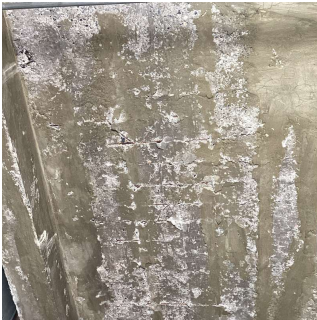
Question	Response
<b>INTERIOR</b>	
<b>STRUCTURAL</b>	
<b>ROOF STRUCTURE</b>	
Deficiency Photo1	
Violations	PH No violations recorded.
Deficiency	CONCRETE: CRACKED/SPALLED/REINFORCEMENT EXPOSED
Deficiency Location/Instance	PH
Deficiency Quantity	20
Quantity Uom	S.F.
Potential Action	REPAIR
Urgency of Action	PRIORITY 3
Purpose of Action	LEVEL 5
Deficiency Photo1	
Violations	PH No violations recorded.
<b>VAULTS-BUNKERS</b>	Does not Exist
<b>AUDITORIUM</b>	Inspected
Instance on 2nd Floor (315 Seats)	Inspected
<b>Ceiling</b>	
Instance on 2nd Floor (315 Seats)	Inspected
Condition	2 - Between Good and Fair
Deficiency	No deficiencies recorded
<b>Door(s)</b>	
Instance on 2nd Floor (315 Seats)	Inspected
Condition	4 - Between Fair and Poor
Deficiency	WOOD: DETERIORATED DOOR
Deficiency Location/Instance	Main Entrance
Deficiency Quantity	2
Quantity Uom	EACH
Potential Action	MAINTENANCE
Urgency of Action	PRIORITY 3
Purpose of Action	LEVEL 2



**NYC Department of Education  
Building Condition Assessment Survey 2023 - 2024**

Architectural Inspection

Q102

Question	Response
<b>INTERIOR</b>	
<b>AUDITORIUM</b>	
<b>Door(s)</b>	
Deficiency Photo1	
	Main Entrance
Violations	No violations recorded.
<b>Fixed H/C Lift</b>	
Instance on 2nd Floor (315 Seats)	Does not Exist
<b>Fixed Seating</b>	
Instance on 2nd Floor (315 Seats)	Inspected
Condition	2 - Between Good and Fair
Deficiency	DAMAGED/BROKEN/INOPERABLE
Deficiency Location/Instance	Seats A/5, M/22, H/17
Deficiency Quantity	3
Quantity Uom	EACH
Potential Action	REPLACE
Urgency of Action	PRIORITY 3
Purpose of Action	LEVEL 2
Deficiency Photo1	
	Seat A/5
Violations	No violations recorded.
<b>Floor Finish</b>	
Instance on 2nd Floor (315 Seats)	Inspected
Condition	2 - Between Good and Fair
Deficiency	CONCRETE: CRACKS
Deficiency Location/Instance	Near Seats M/7, 17, 21, N/3
Deficiency Quantity	100
Quantity Uom	S.F.
Potential Action	REPLACE
Urgency of Action	PRIORITY 3
Purpose of Action	LEVEL 2

**NYC Department of Education  
Building Condition Assessment Survey 2023 - 2024**

Architectural Inspection

Q102

Question	Response
<b>INTERIOR</b>	
<b>AUDITORIUM</b>	
<b>Floor Finish</b>	
Deficiency Photo1	
	Near Seat N/3
Violations	No violations recorded.
<b>Sliding-folding Partition</b>	
Instance on 2nd Floor (315 Seats)	Does not Exist
<b>Stage</b>	
Instance on 2nd Floor (315 Seats)	Inspected
<b>Stage</b>	Inspected
Instance on 2nd Floor (315 Seats)	Inspected
Condition	2 - Between Good and Fair
Deficiency	DAMAGED FLOOR
Deficiency Location/Instance	Center
Deficiency Quantity	10
Quantity Uom	S.F.
Potential Action	REPLACE
Urgency of Action	PRIORITY 3
Purpose of Action	LEVEL 2
Deficiency Photo1	
	Center
Violations	No violations recorded.
<b>Stage Curtain Rigging</b>	
Instance on 2nd Floor (315 Seats)	Inspected
Condition	1 - Good
Deficiency	No deficiencies recorded
<b>Stage Curtains</b>	
Instance on 2nd Floor (315 Seats)	Inspected
Condition	1 - Good
Deficiency	No deficiencies recorded
<b>Walls</b>	
Instance on 2nd Floor (315 Seats)	Inspected
Condition	2 - Between Good and Fair

**NYC Department of Education**  
**Building Condition Assessment Survey 2023 - 2024**

Architectural Inspection

Q102

Question	Response
<b>INTERIOR</b>	
<b>AUDITORIUM</b>	
<b>Walls</b>	
Deficiency	PLASTER: CRACKS/SPALLING
Deficiency Location/Instance	Left Side
Deficiency Quantity	20
Quantity Uom	S.F.
Potential Action	REPLACE
Urgency of Action	PRIORITY 3
Purpose of Action	LEVEL 2
Deficiency Photo1	
	Left Side
Violations	No violations recorded.
<b>Window Curtains/Shades/Blinds</b>	
Instance on 2nd Floor (315 Seats)	Inspected
Condition	1 - Good
Deficiency	No deficiencies recorded
<b>CAFETERIA</b>	
Instance on Basement	Inspected
<b>Ceiling</b>	
Instance on Basement	Inspected
Condition	3 - Fair
Deficiency	ACOUSTIC TILES: DAMAGED/MISSING
Deficiency Location/Instance	Near Entrance, Center
Deficiency Quantity	20
Quantity Uom	S.F.
Potential Action	REPLACE
Urgency of Action	PRIORITY 3
Purpose of Action	LEVEL 2
Deficiency Photo1	
	Near Entrance
Violations	No violations recorded.
Deficiency	GYPSUM BOARD: DAMAGED/DETERIORATED
Deficiency Location/Instance	Center, Near Entrance, Left Side, near Serving area, rear

**NYC Department of Education**  
**Building Condition Assessment Survey 2023 - 2024**

Architectural Inspection



Q102

Question	Response
<b>INTERIOR</b>	
<b>CAFETERIA</b>	
<b>Ceiling</b>	
Deficiency Quantity	160
Quantity Uom	S.F.
Potential Action	REPLACE
Urgency of Action	PRIORITY 3
Purpose of Action	LEVEL 2
Deficiency Photo1	
	Center
Violations	No violations recorded.
<b>Door(s)</b>	
Instance on Basement	Inspected
Condition	2 - Between Good and Fair
Deficiency	No deficiencies recorded
<b>Fixed Equipment</b>	
Instance on Basement	Does not Exist
<b>Floor Finish</b>	
Instance on Basement	Inspected
Condition	2 - Between Good and Fair
Deficiency	VINYL TILES: DETERIORATED SUBSTRATE
Deficiency Location/Instance	Near Entrance, near Serving area, Center, Left Side
Deficiency Quantity	40
Quantity Uom	S.F.
Potential Action	REPLACE
Urgency of Action	PRIORITY 3
Purpose of Action	LEVEL 2
Deficiency Photo1	
	Near Entrance
Violations	No violations recorded.
<b>Sliding-folding Partition</b>	
Instance on Basement	Does not Exist
<b>Stage</b>	
Instance on Basement	Does not Exist

**NYC Department of Education  
Building Condition Assessment Survey 2023 - 2024**

Architectural Inspection



Q102

Question	Response
<b>INTERIOR</b>	
<b>CAFETERIA</b>	
<b>Walls</b>	
Instance on Basement	Inspected
Condition	2 - Between Good and Fair
Deficiency	GYPSUM BOARD: DETERIORATED
Deficiency Location/Instance	Near Entrance, Rear, Near Serving area
Deficiency Quantity	20
Quantity Uom	S.F.
Potential Action	REPLACE
Urgency of Action	PRIORITY 3
Purpose of Action	LEVEL 2
Deficiency Photo1	
Violations	Near Entrance No violations recorded.
<b>Window Curtains/Shades/Blinds</b>	
Instance on Basement	Does not Exist
<b>CLASSROOMS/CORRIDORS/ADMIN SPACES</b>	
<b>Ceiling</b>	
Condition	Inspected
Condition	2 - Between Good and Fair
Deficiency	ACOUSTIC TILES: DAMAGED/MISSING - ACTIVE LEAK
Deficiency Location/Instance	Corridor near Rooms 403, 408
Deficiency Quantity	40
Quantity Uom	S.F.
Potential Action	REPLACE
Urgency of Action	PRIORITY 5
Purpose of Action	LEVEL 2
Deficiency Photo1	
Violations	Corridor near Room 403 No violations recorded.
Deficiency	ACOUSTIC TILES: DAMAGED/MISSING
Deficiency Location/Instance	Corridor near Rooms 411, 108, 008, Rooms 405, 401 and others
Deficiency Quantity	220
Quantity Uom	S.F.

**NYC Department of Education  
Building Condition Assessment Survey 2023 - 2024**

Architectural Inspection

Q102

Question	Response
<b>INTERIOR</b>	
<b>CLASSROOMS/CORRIDORS/ADMIN SPACES</b>	
<b>Ceiling</b>	
Potential Action	REPLACE
Urgency of Action	PRIORITY 3
Purpose of Action	LEVEL 2
Deficiency Photo1	
	Corridor near Room 008
Violations	No violations recorded.
<b>Door(s)</b>	Inspected
Condition	5 - Poor
Deficiency	WOOD: DETERIORATED DOOR
Deficiency Location/Instance	Rooms 329, 325, 323, 321, 221 and others
Deficiency Quantity	11
Quantity Uom	EACH
Potential Action	MAINTENANCE
Urgency of Action	PRIORITY 3
Purpose of Action	LEVEL 2
Deficiency Photo1	
	Room 323
Violations	No violations recorded.
<b>Floor Finish</b>	Inspected
Condition	3 - Fair
Deficiency	TERRAZZO: CRACKS
Deficiency Location/Instance	Corridor near Rooms 225A, 225B
Deficiency Quantity	40
Quantity Uom	S.F.
Potential Action	REPLACE
Urgency of Action	PRIORITY 3
Purpose of Action	LEVEL 2



**NYC Department of Education  
Building Condition Assessment Survey 2023 - 2024**

Architectural Inspection

Q102

**Question**

**Response**

**INTERIOR**

**CLASSROOMS/CORRIDORS/ADMIN SPACES**

**Floor Finish**

Deficiency Photo1



Corridor near Room 225B

Violations

No violations recorded.

Deficiency

VINYL TILES: BROKEN/DETERIORATED/MISSING TILES

Deficiency Location/Instance

Room 338

Deficiency Quantity

40

Quantity Uom

S.F.

Potential Action

REPLACE

Urgency of Action

PRIORITY 5

Purpose of Action

LEVEL 6

Deficiency Photo1



Room 338

Violations

No violations recorded.

Deficiency

SHEET VINYL: TRIPPING HAZARD - ELECTRICAL OUTLET

Deficiency Location/Instance

Room 325

Deficiency Quantity

20

Quantity Uom

S.F.

Potential Action

REMOVE

Urgency of Action

PRIORITY 5

Purpose of Action

LEVEL 6

Deficiency Photo1

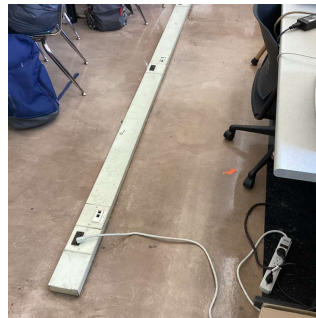

Room 325

Violations

No violations recorded.

**NYC Department of Education**  
**Building Condition Assessment Survey 2023 - 2024**

Architectural Inspection

Q102

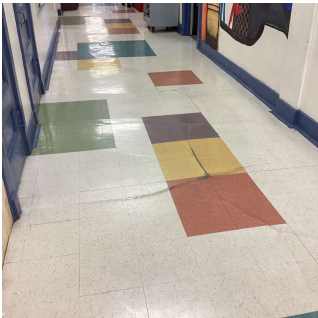
Question	Response
<b>INTERIOR</b>	
<b>CLASSROOMS/CORRIDORS/ADMIN SPACES</b>	
<b>Floor Finish</b>	
Deficiency	VINYL TILES: BROKEN/DETERIORATED/MISSING TILES
Deficiency Location/Instance	Rooms 344, 336, 329, 323, 321 and others
Deficiency Quantity	2,200
Quantity Uom	S.F.
Potential Action	REPLACE
Urgency of Action	PRIORITY 3
Purpose of Action	LEVEL 2
Deficiency Photo1	
	Room 344
Violations	No violations recorded.
Deficiency	VINYL TILES: DETERIORATED SUBSTRATE
Deficiency Location/Instance	Corridor near Rooms 353, 327, 325, 323, 234 and others
Deficiency Quantity	1,300
Quantity Uom	S.F.
Potential Action	REPLACE
Urgency of Action	PRIORITY 3
Purpose of Action	LEVEL 2
Deficiency Photo1	
	Corridor near Room 327
Violations	No violations recorded.
<b>Walls</b>	<b>Inspected</b>
Condition	2 - Between Good and Fair
Deficiency	GYPSUM BOARD: DETERIORATED
Deficiency Location/Instance	Corridor near Rooms 422, 412, 405, 403, 010 and others
Deficiency Quantity	700
Quantity Uom	S.F.
Potential Action	REPLACE
Urgency of Action	PRIORITY 3
Purpose of Action	LEVEL 2

**NYC Department of Education  
Building Condition Assessment Survey 2023 - 2024**

Architectural Inspection

Q102

Question	Response
<b>INTERIOR</b>	
<b>CLASSROOMS/CORRIDORS/ADMIN SPACES</b>	
<b>Walls</b>	
Deficiency Photo1	
Violations	Corridor near Room 010 No violations recorded.
<b>Specialties</b>	Does not Exist
<b>GYMNASIUM</b>	
Instance on Basement	Inspected
<b>Ceiling</b>	
Instance on Basement	Inspected
Condition	2 - Between Good and Fair
Deficiency	No deficiencies recorded
<b>Door(s)</b>	
Instance on Basement	Inspected
Condition	2 - Between Good and Fair
Deficiency	No deficiencies recorded
<b>Fixed Equipment</b>	
Instance on Basement	Inspected
Condition	2 - Between Good and Fair
Deficiency	No deficiencies recorded
<b>Floor Finish</b>	
Instance on Basement	Inspected
Condition	2 - Between Good and Fair
Deficiency	WOOD: DAMAGED/DETERIORATED
Deficiency Location/Instance	Near Drinking Fountain
Deficiency Quantity	10
Quantity Uom	S.F.
Potential Action	REPLACE
Urgency of Action	PRIORITY 3
Purpose of Action	LEVEL 2
Deficiency Photo1	
Violations	Near Drinking Fountain No violations recorded.

**NYC Department of Education  
Building Condition Assessment Survey 2023 - 2024**

Architectural Inspection



Q102

Question	Response
<b>INTERIOR</b>	
<b>GYMNASIUM</b>	
<b>Seating</b>	
Instance on Basement	Inspected
Condition	2 - Between Good and Fair
Deficiency	No deficiencies recorded
<b>Sliding-folding Partition</b>	
Instance on Basement	Inspected
Condition	2 - Between Good and Fair
Deficiency	No deficiencies recorded
<b>Stage</b>	
Instance on Basement	Does not Exist
<b>Walls</b>	
Instance on Basement	Inspected
Condition	2 - Between Good and Fair
Deficiency	WALL PADDING: DETERIORATED
Deficiency Location/Instance	Left Side
Deficiency Quantity	20
Quantity Uom	S.F.
Potential Action	REPLACE
Urgency of Action	PRIORITY 3
Purpose of Action	LEVEL 2
Deficiency Photo1	
	Left Side
Violations	No violations recorded.
<b>Window Curtains/Shades/Blinds</b>	
Instance on Basement	Does not Exist
<b>INTERIOR DOOR HARDWARE</b>	
Instance on Basement	Inspected
Condition	2 - Between Good and Fair
Deficiency	No deficiencies recorded
<b>INTERIOR GUARDS</b>	
Instance on Basement	Inspected
Condition	2 - Between Good and Fair
Deficiency	No deficiencies recorded
<b>KITCHEN</b>	
Instance on Basement	Inspected
<b>Ceiling</b>	
Instance on Basement	Inspected
Condition	3 - Fair
Deficiency	GYPSUM BOARD: DAMAGED/DETERIORATED
Deficiency Location/Instance	Room 003F
Deficiency Quantity	20
Quantity Uom	S.F.

**NYC Department of Education  
Building Condition Assessment Survey 2023 - 2024**

Architectural Inspection

Q102

Question	Response
<b>INTERIOR</b>	
<b>KITCHEN</b>	
<b>Ceiling</b>	
Potential Action	REPLACE
Urgency of Action	PRIORITY 3
Purpose of Action	LEVEL 2
Deficiency Photo1	
	Room 003F
Violations	No violations recorded.
Deficiency	ACOUSTIC TILES: DAMAGED/MISSING
Deficiency Location/Instance	Room 003F
Deficiency Quantity	10
Quantity Uom	S.F.
Potential Action	REPLACE
Urgency of Action	PRIORITY 3
Purpose of Action	LEVEL 2
Deficiency Photo1	
	Room 003F
Violations	No violations recorded.
Deficiency	METAL PAN: DAMAGED/MISSING
Deficiency Location/Instance	Near Sinks
Deficiency Quantity	10
Quantity Uom	S.F.
Potential Action	REPLACE
Urgency of Action	PRIORITY 3
Purpose of Action	LEVEL 2

**NYC Department of Education  
Building Condition Assessment Survey 2023 - 2024**

Architectural Inspection

Q102

Question	Response
----------	----------

**INTERIOR**

**KITCHEN**

**Ceiling**

Deficiency Photo1



Near Sinks

Violations

No violations recorded.

**Door(s)**

Instance on Basement

Inspected

Condition

2 - Between Good and Fair

Deficiency

No deficiencies recorded

**Floor Finish**

Instance on Basement

Inspected

Condition

2 - Between Good and Fair

Deficiency

No deficiencies recorded

**Walls**

Instance on Basement

Inspected

Condition

2 - Between Good and Fair

Deficiency

No deficiencies recorded

**LIBRARY**

Inspected

Instance on Room 133

Inspected

**Built-in Furnishing**

Instance on Room 133

Does not Exist

**Ceiling**

Instance on Room 133

Inspected

Condition

2 - Between Good and Fair

Deficiency

ACOUSTIC TILES: DAMAGED/MISSING

Deficiency Location/Instance

Center

Deficiency Quantity

10

Quantity Uom

S.F.

Potential Action

REPLACE

Urgency of Action

PRIORITY 3

Purpose of Action

LEVEL 2

Deficiency Photo1



Center

**NYC Department of Education**  
**Building Condition Assessment Survey 2023 - 2024**

Architectural Inspection

Q102

Question	Response
<b>INTERIOR</b>	
<b>LIBRARY</b>	
<b>Ceiling</b>	
Violations	No violations recorded.
<b>Door(s)</b>	
Instance on Room 133	Inspected
Condition	2 - Between Good and Fair
Deficiency	No deficiencies recorded
<b>Floor Finish</b>	
Instance on Room 133	Inspected
Condition	2 - Between Good and Fair
Deficiency	VINYL TILES: DETERIORATED SUBSTRATE
Deficiency Location/Instance	Near Entrance, Rear
Deficiency Quantity	20
Quantity Uom	S.F.
Potential Action	REPLACE
Urgency of Action	PRIORITY 3
Purpose of Action	LEVEL 2
Deficiency Photo1	
Violations	Near Entrance No violations recorded.
<b>Walls</b>	
Instance on Room 133	Inspected
Condition	2 - Between Good and Fair
Deficiency	No deficiencies recorded
<b>LOCKER ROOM</b>	
Instance on Basement - Girls (287 Lockers)	Inspected
Alternative use	Yes
Instance on Basement - Boys (208 Lockers)	Inspected
Alternative use	Yes
<b>Ceiling</b>	
Instance on Basement - Girls (287 Lockers)	Inspected
Condition	2 - Between Good and Fair
Deficiency	GYPSON BOARD: DAMAGED/DETERIORATED
Deficiency Location/Instance	Center
Deficiency Quantity	10
Quantity Uom	S.F.
Potential Action	REPLACE
Urgency of Action	PRIORITY 3
Purpose of Action	LEVEL 2



**NYC Department of Education  
Building Condition Assessment Survey 2023 - 2024**

Architectural Inspection

Q102

Question	Response
<b>INTERIOR</b>	
<b>LOCKER ROOM</b>	
<b>Ceiling</b>	
Deficiency Photo1	
Center	Center
Violations	No violations recorded.
Instance on Basement - Boys (208 Lockers)	Inspected
Condition	2 - Between Good and Fair
Deficiency	GYPSON BOARD: DAMAGED/DETERIORATED
Deficiency Location/Instance	Center, Near Entrance
Deficiency Quantity	20
Quantity Uom	S.F.
Potential Action	REPLACE
Urgency of Action	PRIORITY 3
Purpose of Action	LEVEL 2
Deficiency Photo1	
Center	Center
Violations	No violations recorded.
<b>Door(s)</b>	
Instance on Basement - Girls (287 Lockers)	Inspected
Condition	2 - Between Good and Fair
Deficiency	No deficiencies recorded
Instance on Basement - Boys (208 Lockers)	Inspected
Condition	2 - Between Good and Fair
Deficiency	No deficiencies recorded
<b>Floor Finish</b>	
Instance on Basement - Girls (287 Lockers)	Inspected
Condition	2 - Between Good and Fair
Deficiency	No deficiencies recorded
Instance on Basement - Boys (208 Lockers)	Inspected
Condition	2 - Between Good and Fair
Deficiency	No deficiencies recorded
<b>Locker Room Lockers</b>	
Instance on Basement - Girls (287 Lockers)	Inspected

**NYC Department of Education**  
**Building Condition Assessment Survey 2023 - 2024**

Architectural Inspection

Q102

Question	Response
<b>INTERIOR</b>	
<b>LOCKER ROOM</b>	
<b>Locker Room Lockers</b>	
Condition	2 - Between Good and Fair
Deficiency	No deficiencies recorded
Instance on Basement - Boys (208 Lockers)	Inspected
Condition	2 - Between Good and Fair
Deficiency	No deficiencies recorded
<b>Walls</b>	
Instance on Basement - Girls (287 Lockers)	Inspected
Condition	2 - Between Good and Fair
Deficiency	GYP SUM BOARD: DETERIORATED
Deficiency Location/Instance	Center
Deficiency Quantity	10
Quantity Uom	S.F.
Potential Action	REPLACE
Urgency of Action	PRIORITY 3
Purpose of Action	LEVEL 2
Deficiency Photo1	
Violations	Center No violations recorded.
<b>MULTI-PURPOSE ROOM</b>	
Instance on 1st Floor	Inspected
Instance on 1st Floor	Inspected
<b>Ceiling</b>	
Instance on 1st Floor	Inspected
Condition	2 - Between Good and Fair
Deficiency	No deficiencies recorded
<b>Door(s)</b>	
Instance on 1st Floor	Inspected
Condition	2 - Between Good and Fair
Deficiency	No deficiencies recorded
<b>Fixed Equipment</b>	
Instance on 1st Floor	Does not Exist
<b>Floor Finish</b>	
Instance on 1st Floor	Inspected
Condition	2 - Between Good and Fair
Deficiency	VINYL TILES: DETERIORATED SUBSTRATE
Deficiency Location/Instance	Center
Deficiency Quantity	20
Quantity Uom	S.F.
Potential Action	REPLACE
Urgency of Action	PRIORITY 3

**NYC Department of Education  
Building Condition Assessment Survey 2023 - 2024**

Architectural Inspection

Q102

Question	Response
<b>INTERIOR</b>	
<b>MULTI-PURPOSE ROOM</b>	
<b>Floor Finish</b>	
Purpose of Action	LEVEL 2
Deficiency Photo1	
Violations	Center No violations recorded.
<b>Sliding-folding Partition</b>	
Instance on 1st Floor	Does not Exist
<b>Stage</b>	
Instance on 1st Floor	Does not Exist
<b>Walls</b>	
Instance on 1st Floor	Inspected
Condition	2 - Between Good and Fair
Deficiency	GYPSUM BOARD: DETERIORATED
Deficiency Location/Instance	Right Side Near Windows
Deficiency Quantity	10
Quantity Uom	S.F.
Potential Action	REPLACE
Urgency of Action	PRIORITY 3
Purpose of Action	LEVEL 2
Deficiency Photo1	
Violations	Right Side Near Windows No violations recorded.
<b>Window Curtains/Shades/Blinds</b>	
Instance on 1st Floor	Does not Exist
<b>SCIENCE DEMO ROOM</b>	
Does not Exist	
<b>SCIENCE LAB</b>	
Inspected	
Instance on Rooms 424, 428, 202	Inspected
Alternative use	No
<b>Fixed Equipment</b>	
Instance on Rooms 424, 428, 202	Inspected
Condition	2 - Between Good and Fair
Deficiency	No deficiencies recorded

**NYC Department of Education**  
**Building Condition Assessment Survey 2023 - 2024**

Architectural Inspection

Q102

Question	Response
<b>INTERIOR</b>	
<b>SCIENCE PREP ROOM</b>	
	Inspected
Instance on Room 426	Inspected
Alternative use	No
Instance on Room 204	Inspected
Alternative use	Yes
<b>Fixed Equipment</b>	
Instance on Room 426	Inspected
Condition	2 - Between Good and Fair
Deficiency	No deficiencies recorded
Instance on Room 204	Inspected
Condition	2 - Between Good and Fair
Deficiency	No deficiencies recorded
<b>SHOWER ROOM</b>	
	Does not Exist
<b>STAIRS/RAMPS: INTERIOR</b>	
	Inspected
Do Letter Stair Signs Exist?	Yes
<b>Ceiling</b>	
	Inspected
Condition	2 - Between Good and Fair
Deficiency	GYPSUM BOARD: DAMAGED/DETERIORATED
Deficiency Location/Instance	Stair A/4
Deficiency Quantity	10
Quantity Uom	S.F.
Potential Action	REPLACE
Urgency of Action	PRIORITY 3
Purpose of Action	LEVEL 2
Deficiency Photo1	
	Stair A/4
Violations	No violations recorded.
<b>Door(s)</b>	
	Inspected
Condition	4 - Between Fair and Poor
Deficiency	METAL CLAD WOOD: DETERIORATED DOOR
Deficiency Location/Instance	Stair G/1 Vestibule
Deficiency Quantity	1
Quantity Uom	EACH
Potential Action	MAINTENANCE
Urgency of Action	PRIORITY 3
Purpose of Action	LEVEL 2

**NYC Department of Education**  
**Building Condition Assessment Survey 2023 - 2024**

Architectural Inspection



Q102

Question	Response
<b>INTERIOR</b>	
<b>STAIRS/RAMPS: INTERIOR</b>	
<b>Door(s)</b>	
Deficiency Photo1           Violations	  Stair G/1 Vestibule  No violations recorded.
Deficiency Deficiency Location/Instance Deficiency Quantity Quantity Uom Potential Action Urgency of Action Purpose of Action Deficiency Photo1           Violations	METAL CLAD WOOD: DETERIORATED DOOR AND FRAME Stair E/1 Vestibule 1 EACH MAINTENANCE PRIORITY 3 LEVEL 2             Stair E/1 Vestibule  No violations recorded.
Deficiency Deficiency Location/Instance Deficiency Quantity Quantity Uom Potential Action Urgency of Action Purpose of Action Deficiency Photo1           Violations	METAL: MISSING DOOR Stairs H/1, J/1 4 EACH MAINTENANCE PRIORITY 3 LEVEL 2             Stair H/1  No violations recorded.

**NYC Department of Education  
Building Condition Assessment Survey 2023 - 2024**

Architectural Inspection

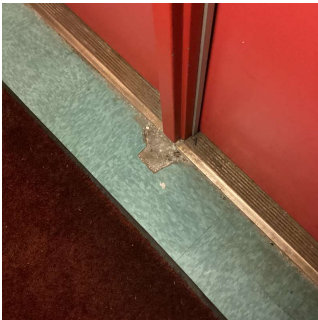
Q102

Question	Response
<b>INTERIOR</b>	
<b>STAIRS/RAMPS: INTERIOR</b>	
<b>Partition</b>	Does not Exist
<b>Railings</b>	Inspected
Condition	2 - Between Good and Fair
Deficiency	No deficiencies recorded
<b>Stairs and Landings</b>	Inspected
Condition	2 - Between Good and Fair
Deficiency	VINYL TILES: BROKEN/DETERIORATED/MISSING TILES
Deficiency Location/Instance	Stair G/1 Vestibule
Deficiency Quantity	10
Quantity Uom	S.F.
Potential Action	REPLACE
Urgency of Action	PRIORITY 3
Purpose of Action	LEVEL 2
Deficiency Photo1	
Violations	Stair G/1 Vestibule No violations recorded.
Deficiency	STONE: BROKEN/MISSING
Deficiency Location/Instance	Exit 7
Deficiency Quantity	10
Quantity Uom	S.F.
Potential Action	REPLACE
Urgency of Action	PRIORITY 3
Purpose of Action	LEVEL 2
Deficiency Photo1	
Violations	Exit 7 No violations recorded.
Deficiency	STONE: WORN-OUT TREAD/NOSINGS
Deficiency Location/Instance	Exit 7
Deficiency Quantity	40
Quantity Uom	S.F.
Potential Action	REPLACE
Urgency of Action	PRIORITY 3

**NYC Department of Education  
Building Condition Assessment Survey 2023 - 2024**

Architectural Inspection

Q102

Question	Response
----------	----------

**INTERIOR**

**STAIRS/RAMPS: INTERIOR**

**Stairs and Landings**

Purpose of Action  
Deficiency Photo1

LEVEL 2

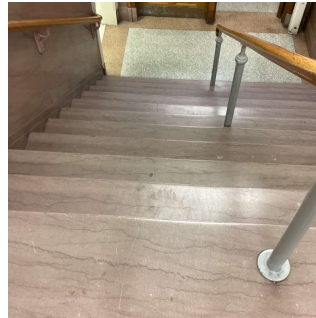

Exit 7  
No violations recorded.

Violations

Deficiency

ROLLED ASPHALT: CRACKS

Deficiency Location/Instance

Stair G/3

Deficiency Quantity

20

Quantity Uom

S.F.

Potential Action

REPLACE

Urgency of Action

PRIORITY 3

Purpose of Action

LEVEL 2

Deficiency Photo1



Stair G/3  
No violations recorded.

Violations

Deficiency

CONCRETE: CRACKS/SPALLING - MAJOR

Deficiency Location/Instance

Stair A/3

Deficiency Quantity

10

Quantity Uom

S.F.

Potential Action

REPLACE

Urgency of Action

PRIORITY 3

Purpose of Action

LEVEL 2

Deficiency Photo1





Stair A/3



**NYC Department of Education  
Building Condition Assessment Survey 2023 - 2024**

Architectural Inspection

Q102

Question	Response
<b>INTERIOR</b>	
<b>STAIRS/RAMPS: INTERIOR</b>	
<b>Stairs and Landings</b>	Inspected
Violations	No violations recorded.
<b>Walls</b>	Inspected
Condition	2 - Between Good and Fair
Deficiency	CERAMIC TILE: BROKEN/ MISSING
Deficiency Location/Instance	Stairs E/1 Vestibule, G/1 Vestibule
Deficiency Quantity	20
Quantity Uom	S.F.
Potential Action	REPLACE
Urgency of Action	PRIORITY 3
Purpose of Action	LEVEL 2
Deficiency Photo1	
Violations	Stair G/1 Vestibule No violations recorded.
Deficiency	PLASTER: CRACKS/SPALLING
Deficiency Location/Instance	Stairs E/3, J/1
Deficiency Quantity	20
Quantity Uom	S.F.
Potential Action	REPLACE
Urgency of Action	PRIORITY 3
Purpose of Action	LEVEL 2
Deficiency Photo1	
Violations	Stair E/3 No violations recorded.
Deficiency	MASONRY: CRACKS/SPALLING
Deficiency Location/Instance	Stairs A/3, B/4
Deficiency Quantity	40
Quantity Uom	S.F.
Potential Action	REPLACE
Urgency of Action	PRIORITY 3
Purpose of Action	LEVEL 2

**NYC Department of Education  
Building Condition Assessment Survey 2023 - 2024**

Architectural Inspection

Q102

Question	Response
<b>INTERIOR</b>	
<b>STAIRS/RAMPS: INTERIOR</b>	
<b>Walls</b>	Inspected
Deficiency Photo1	
Violations	Stair B/4 No violations recorded.
<b>TOILET ROOMS - STAFF</b>	
<b>Ceiling</b>	Inspected
Condition	2 - Between Good and Fair
Deficiency	ACOUSTIC TILES: DAMAGED/MISSING
Deficiency Location/Instance	Room 314
Deficiency Quantity	10
Quantity Uom	S.F.
Potential Action	REPLACE
Urgency of Action	PRIORITY 3
Purpose of Action	LEVEL 2
Deficiency Photo1	
Violations	Room 314 No violations recorded.
<b>Door(s)</b>	Inspected
Condition	2 - Between Good and Fair
Deficiency	No deficiencies recorded
<b>Floor Finish</b>	Inspected
Condition	2 - Between Good and Fair
Deficiency	CERAMIC TILE: BROKEN/MISSING TILES
Deficiency Location/Instance	Room 414
Deficiency Quantity	10
Quantity Uom	S.F.
Potential Action	REPLACE
Urgency of Action	PRIORITY 3
Purpose of Action	LEVEL 2

**NYC Department of Education  
Building Condition Assessment Survey 2023 - 2024**

Architectural Inspection

Q102

Question	Response
<b>INTERIOR</b>	
<b>TOILET ROOMS - STAFF</b>	
<b>Floor Finish</b>	
Deficiency Photo1	
Violations	Room 414 No violations recorded.
<b>Stalls</b>	Does not Exist
<b>Walls</b>	Inspected
Condition	2 - Between Good and Fair
Deficiency	No deficiencies recorded
<b>TOILET ROOMS - STUDENTS</b>	
<b>Ceiling</b>	Inspected
Condition	2 - Between Good and Fair
Deficiency	ACOUSTIC TILES: DAMAGED/MISSING
Deficiency Location/Instance	Room 116
Deficiency Quantity	10
Quantity Uom	S.F.
Potential Action	REPLACE
Urgency of Action	PRIORITY 3
Purpose of Action	LEVEL 2
Deficiency Photo1	
Violations	Room 116 No violations recorded.
Deficiency	GYPSUM BOARD: DAMAGED/DETERIORATED
Deficiency Location/Instance	Room 418
Deficiency Quantity	10
Quantity Uom	S.F.
Potential Action	REPLACE
Urgency of Action	PRIORITY 3
Purpose of Action	LEVEL 2

**NYC Department of Education  
Building Condition Assessment Survey 2023 - 2024**

Architectural Inspection

Q102

Question	Response
<b>INTERIOR</b>	
<b>TOILET ROOMS - STUDENTS</b>	
<b>Ceiling</b>	
Deficiency Photo1	
Violations	Room 418 No violations recorded.
<b>Door(s)</b>	Inspected
Condition	2 - Between Good and Fair
Deficiency	No deficiencies recorded
<b>Floor Finish</b>	Inspected
Condition	2 - Between Good and Fair
Deficiency	No deficiencies recorded
<b>Stalls</b>	Inspected
Condition	2 - Between Good and Fair
Deficiency	BROKEN/MISSING
Deficiency Location/Instance	Room 010
Deficiency Quantity	1
Quantity Uom	EACH
Potential Action	REPLACE
Urgency of Action	PRIORITY 3
Purpose of Action	LEVEL 2
Deficiency Photo1	
Violations	Room 010 No violations recorded.
<b>Walls</b>	Inspected
Condition	2 - Between Good and Fair
Deficiency	CERAMIC TILE: BROKEN/ MISSING
Deficiency Location/Instance	Room 012
Deficiency Quantity	10
Quantity Uom	S.F.
Potential Action	REPLACE
Urgency of Action	PRIORITY 3
Purpose of Action	LEVEL 2

**NYC Department of Education  
Building Condition Assessment Survey 2023 - 2024**

Architectural Inspection



Q102

Question	Response
<b>INTERIOR</b>	
<b>TOILET ROOMS - STUDENTS</b>	
<b>Walls</b>	
Deficiency Photo1	
Violations	Room 012 No violations recorded.
<b>LIFE SAFETY</b>	Inspected
<b>F.D. HOLDING AREA</b>	Does not Exist
<b>STEEL STAIRS</b>	Does not Exist
<b>SITE</b>	Inspected
<b>CONTAINERIZATION</b>	Does not Exist
<b>Drainage System for Asphalt</b>	Inspected
<b>Catch Basins/Manhole - Surrounded by asphalt</b>	Inspected
Condition	2 - Between Good and Fair
Deficiency	No deficiencies recorded
<b>Culverts - Asphalt Covering</b>	Does not Exist
<b>Drainage System for Concrete</b>	Inspected
<b>Catch Basins/Manhole - Surrounded by concrete</b>	Inspected
Condition	2 - Between Good and Fair
Deficiency	No deficiencies recorded
<b>Culverts - Concrete Covering</b>	Does not Exist
<b>Drainage System for Soil</b>	Inspected
<b>Catch Basins/Manhole - Surrounded by Soil</b>	Inspected
Condition	2 - Between Good and Fair
Deficiency	No deficiencies recorded
<b>Culverts - Soil Covering</b>	Does not Exist
<b>DRINKING FOUNTAINS</b>	Does not Exist
<b>FENCES</b>	Inspected
Condition	3 - Fair
Deficiency	CONCRETE CURB: DAMAGED/DETERIORATED
Deficiency Location/Instance	Schoolyard
Deficiency Quantity	40
Quantity Uom	S.F.
Potential Action	REPLACE
Urgency of Action	PRIORITY 3
Purpose of Action	LEVEL 2

**NYC Department of Education  
Building Condition Assessment Survey 2023 - 2024**

Architectural Inspection

Q102

Question	Response
<b>SITE</b>	
<b>FENCES</b>	
Deficiency Photo1	
Violations	Schoolyard No violations recorded.
Deficiency	ALUMINUM: MISSING SECTIONS
Deficiency Location/Instance	Schoolyard
Deficiency Quantity	80
Quantity Uom	S.F.
Potential Action	REPLACE
Urgency of Action	PRIORITY 3
Purpose of Action	LEVEL 2
Deficiency Photo1	
Violations	Schoolyard No violations recorded.
Deficiency	CHAIN LINK: DAMAGED/DETERIORATED
Deficiency Location/Instance	Schoolyard
Deficiency Quantity	150
Quantity Uom	S.F.
Potential Action	REPLACE
Urgency of Action	PRIORITY 3
Purpose of Action	LEVEL 2
Deficiency Photo1	
Violations	Schoolyard No violations recorded.
<b>IRRIGATION SYSTEM</b>	
	Does not Exist

**NYC Department of Education  
Building Condition Assessment Survey 2023 - 2024**

Architectural Inspection

Q102



Question	Response
<b>SITE</b>	
<b>IRRIGATION SYSTEM</b>	Does not Exist
<b>PAVING</b>	Inspected
<b>Student Non-Use</b>	Inspected
Gravel Exists?	No
<b>Asphalt</b>	Inspected
Condition	1 - Good
Deficiency	No deficiencies recorded
<b>Concrete</b>	Does not Exist
<b>Pavers</b>	Does not Exist
<b>Student Use</b>	Inspected
Gravel Exists?	No
<b>Asphalt</b>	Inspected
Condition	4 - Between Fair and Poor
Deficiency	CRACKS - MAJOR
Deficiency Location/Instance	Schoolyard
Deficiency Quantity	1,200
Quantity Uom	S.F.
Potential Action	REPLACE
Urgency of Action	PRIORITY 3
Purpose of Action	LEVEL 2
Deficiency Photo1	
Violations	Schoolyard No violations recorded.
<b>Concrete</b>	Inspected
Condition	2 - Between Good and Fair
Deficiency	No deficiencies recorded
<b>Pavers</b>	Inspected
Condition	2 - Between Good and Fair
Deficiency	No deficiencies recorded
<b>Site Sidewalks &amp; Walkways</b>	Inspected
<b>Asphalt</b>	Inspected
Condition	3 - Fair
Deficiency	CRACKS - MAJOR
Deficiency Location/Instance	Exit 3
Deficiency Quantity	50
Quantity Uom	S.F.
Potential Action	REPLACE
Urgency of Action	PRIORITY 3
Purpose of Action	LEVEL 2



**NYC Department of Education  
Building Condition Assessment Survey 2023 - 2024**

Architectural Inspection



Q102

Question	Response
<b>SITE</b>	
<b>PAVING</b>	Inspected
<b>Site Sidewalks &amp; Walkways</b>	
<b>Asphalt</b>	
Deficiency Photo1	
Violations	Exit 3 No violations recorded.
<b>Concrete</b>	Inspected
Condition	3 - Fair
Deficiency	CRACKS - MAJOR
Deficiency Location/Instance	Van Horn Street, Exits 9, 2
Deficiency Quantity	200
Quantity Uom	S.F.
Potential Action	REPLACE
Urgency of Action	PRIORITY 3
Purpose of Action	LEVEL 2
Deficiency Photo1	
Violations	Van Horn Street No violations recorded.
<b>Pavers</b>	Does not Exist
<b>DOT Sidewalk</b>	Inspected
<b>Asphalt</b>	Does not Exist
<b>Concrete</b>	Inspected
Condition	4 - Between Fair and Poor
Deficiency	DAMAGED/DETERIORATED/MISSING SECTIONS
Deficiency Location/Instance	Van Horn Street
Deficiency Quantity	675
Quantity Uom	S.F.
Potential Action	REPLACE
Urgency of Action	PRIORITY 3
Purpose of Action	LEVEL 2

**NYC Department of Education  
Building Condition Assessment Survey 2023 - 2024**

Architectural Inspection

Q102

Question	Response
<b>SITE</b>	
<b>PAVING</b>	
<b>DOT Sidewalk</b>	
<b>Concrete</b>	
Deficiency Photo1	
Violations	Van Horn Street No violations recorded.
<b>Pavers</b>	Does not Exist
<b>PLAYGROUNDS</b>	Inspected
Instance on West side of Schoolyard	Inspected
Instance on East side of Schoolyard	Inspected
<b>Benches</b>	
Instance on West side of Schoolyard	Does not Exist
Instance on East side of Schoolyard	Does not Exist
<b>Fence</b>	
Instance on West side of Schoolyard	Inspected
Condition	2 - Between Good and Fair
Deficiency	ALUMINUM: DAMAGED/DETERIORATED
Deficiency Location/Instance	Main Entrance
Deficiency Quantity	40
Quantity Uom	S.F.
Potential Action	REPLACE
Urgency of Action	PRIORITY 3
Purpose of Action	LEVEL 2
Deficiency Photo1	
Violations	Main Entrance No violations recorded.
<b>Pavement</b>	
Instance on West side of Schoolyard	Does not Exist
Instance on East side of Schoolyard	Does not Exist
<b>Play Equipment</b>	
Instance on West side of Schoolyard	Inspected
Condition	2 - Between Good and Fair

**NYC Department of Education  
Building Condition Assessment Survey 2023 - 2024**

Architectural Inspection

Q102

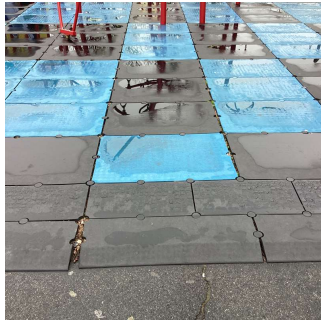
Question	Response
<b>SITE</b>	
<b>PLAYGROUNDS</b>	
<b>Play Equipment</b>	
Deficiency	No deficiencies recorded
Instance on East side of Schoolyard	Inspected
Condition	2 - Between Good and Fair
Deficiency	No deficiencies recorded
<b>Safety Surfacing</b>	
Instance on West side of Schoolyard	Inspected
Condition	3 - Fair
Deficiency	DETERIORATED/MISSING
Deficiency Location/Instance	Entrance Ramp, Center, Rear
Deficiency Quantity	50
Quantity Uom	S.F.
Potential Action	REPLACE
Urgency of Action	PRIORITY 3
Purpose of Action	LEVEL 2
Deficiency Photo1	
	Rear
Violations	No violations recorded.
Instance on East side of Schoolyard	Inspected
Condition	3 - Fair
Deficiency	DETERIORATED/MISSING
Deficiency Location/Instance	East Side, West Side
Deficiency Quantity	50
Quantity Uom	S.F.
Potential Action	MAINTENANCE
Urgency of Action	PRIORITY 3
Purpose of Action	LEVEL 2
Deficiency Photo1	
	East Side
Violations	No violations recorded.
<b>Unpaved Area</b>	
Instance on East side of Schoolyard	Does not Exist

**NYC Department of Education**  
**Building Condition Assessment Survey 2023 - 2024**

Architectural Inspection



Q102

Question	Response
<b>SITE</b>	
<b>PLAYGROUNDS</b>	Inspected
<b>Unpaved Area</b>	
Instance on West side of Schoolyard	Does not Exist
<b>PLAYING SURFACE</b>	Does not Exist
<b>RETAINING WALLS</b>	Inspected
Are there any Retaining Walls 6' OR higher facing public street/sidewalk?	No
Condition	3 - Fair
Deficiency	CAST IN PLACE CONCRETE: CRACKS/SPALLING - MAJOR
Deficiency Location/Instance	Schoolyard
Deficiency Quantity	140
Quantity Uom	S.F.
Potential Action	REPLACE
Urgency of Action	PRIORITY 3
Purpose of Action	LEVEL 2
Deficiency Photo1	
Schoolyard	Schoolyard
Violations	No violations recorded.
<b>SEATING</b>	Inspected
<b>Benches</b>	Inspected
<b>Concrete</b>	Inspected
Condition	2 - Between Good and Fair
Deficiency	No deficiencies recorded
<b>Metal/Wood/Plastic</b>	Does not Exist
<b>Bleachers</b>	Does not Exist
<b>SITE WALLS (NOT RETAINING WALLS)</b>	Does not Exist
<b>STAIRS/RAMPS: EXTERIOR</b>	Inspected
<b>Railings</b>	Inspected
Condition	2 - Between Good and Fair
Deficiency	No deficiencies recorded
<b>Site Cheek/flank Walls</b>	Inspected
Condition	2 - Between Good and Fair
Deficiency	CAST IN PLACE CONCRETE: CRACKS/SPALLING - MAJOR
Deficiency Location/Instance	Schoolyard
Deficiency Quantity	10
Quantity Uom	S.F.
Potential Action	REPLACE
Urgency of Action	PRIORITY 3
Purpose of Action	LEVEL 2

**NYC Department of Education  
Building Condition Assessment Survey 2023 - 2024**

Architectural Inspection

Q102

Question	Response
<b>SITE</b>	
<b>STAIRS/RAMPS: EXTERIOR</b>	
<b>Site Cheek/flank Walls</b>	
Deficiency Photo1	
Violations	Schoolyard No violations recorded.
<b>Stairs/ramps</b>	
Condition	Inspected
Deficiency	2 - Between Good and Fair
Deficiency Location/Instance	CAST IN PLACE CONCRETE: CRACKS/SPALLING - MAJOR
Deficiency Location/Instance	Schoolyard
Deficiency Quantity	40
Quantity Uom	S.F.
Potential Action	REPLACE
Urgency of Action	PRIORITY 3
Purpose of Action	LEVEL 2
Deficiency Photo1	
Violations	Schoolyard No violations recorded.
<b>ARTWORK</b>	Does not Exist