

**NYC Department of Education
Building Condition Assessment Survey 2023-2024**

Architectural Inspection

M015

Asset: P.S. 15 - MANHATTAN, 333 EAST 4 STREET, MANHATTAN, NY, 10009

Inspection Id	Inspection Type	Time In	Last Edited
1643	ARCHITECTURAL - ASSOCIATE	2023-12-13 10:53AM	2024-06-20 09:23AM
1688	ARCHITECTURAL - SENIOR	2023-12-13 09:00AM	2024-04-15 04:00PM

Asset Data

Question	Answer
Was the Building Fully Accessible for Inspection?	No
Inspection Inaccessible Comment	Shower Rooms (storage)
Principal(s) Information	
Principal Name	Jeanne Bradley
Principal Organization	M094 SPED
Meeting with Principal?	No
Principal Feedback	The Principal's comments are as follows: 1. The floor drains in the 2nd Floor Boys Toilet Room is clogged and requires repair. 2. The HVAC System is inconsistent in its functionality. There are rooms which are very cold and other rooms which are very hot.
Principal Name	Irene Sanchez
Principal Organization	P.S. 15
Meeting with Principal?	Yes
Principal Feedback	The Principal had no comments about the condition of the building at this time.
Custodian	William Hernandez
Was the Custodian Present?	No
Fireman	Brian Walker
Was the Fireman Present?	Yes
Building Square Footage	60,000
Comments on the Area (for Athletic Field, Playing Surfaces, Leased Spaces)	None
Comments on the Stories (Floors) plus Basements	5+B
Comments on the Year Built	1904
Student Population	242
Staff Population	98
Comments on the Number of Classrooms	30
Weather	Fair
Facade Photo	



East 4th Street - Northwest View

**NYC Department of Education
Building Condition Assessment Survey 2023-2024**

Architectural Inspection

M015

Main Entrance Photo



Facade A - East 4th Street

Roof Photo



Roof 1 - East View

Do Stormwater Management/Green Infrastructure systems exist?

No

Type

No Storm Water Management Type Selected

Have any Systems/Major Building Components been upgraded?

Systems: Exit 1 and Exit 2 stairs on East 4th Street repaired

Years: 2020

Systems: New Playground upgrade, Exterior Door repainted

Years: 2017

Systems: Exterior Door repainted

Years: 2017

Systems: Limited Exterior Door and Roof Fence repairs

Years: 2016

Systems: Complete Roofing replacement including Parapets, Coping, Plaza Deck, Roof Barrier and Roof Fence; Limited Exterior Masonry repairs and Foundation Wall Waterproofing.

Years: 2008

Systems: New Library

Years: 2006

Systems: New HC Auditorium Lift

Years: 2005

Systems: New HC Auditorium Lift

Years: 2005

Systems: Complete Windows and Exterior Guards replacement

Years: 2000

1955 (+10,000 SF)

Have there been any New Building Additions?

Tandem

No Tandem

**NYC Department of Education
Building Condition Assessment Survey 2023-2024**

Architectural Inspection

M015

Leased Space? No

Priority Condition

Exist Last Year?	Priority Category	Condition Description	Component Affected	Location Description	Person(s) Notified	Person(s) Title	Photo Image
No condition recorded							

Structural Engineer Required

Structural Condition Type	Condition Description	Component Affected	Location Description	Person(s) Notified	Person(s) Title	Photo Image
No condition recorded						

Programmatic Accessibility

Programmatic Accessibility Status Question	Response
Is the Primary or secondary entrance on an accessible route?	Yes
Is the building a multi-story building?	Yes
Are All floors of the building accessible through compliant means?	No
Are SOME floors other than the 1st floor and basement accessible through compliant means?	No
Do any of the following spaces exist on the 1st floor or basement? Classroom, Art Room, Auditorium, Cafeteria, Computer, Gymnasiums, Library, Multipurpose Room, Science Labs	Yes
For the rooms that do exist, are SOME of them accessible on the 1st floor or basement?	Yes
Boys and Girls or Unisex accessible toilets exist on the 1st floor?	Yes

Physical Breakdown Structure	Exists	Complies	Required	Deficiency	Assistive Listening System	Fire Alarm Strobe
------------------------------	--------	----------	----------	------------	----------------------------	-------------------

PROGRAMMATIC ACCESSIBILITY

Exterior Routes

Exterior Entrances & Exits		Yes				
Exterior H/C Lifts	No		Yes			
Exterior Ramps and Railings	Yes	Yes				

Interior Routes

Corridor and Lobby H/C Lifts	No		No			
Interior Corridor Doors And Hardware	Yes	Yes				
Interior Corridors & Lobbies		No				
Interior Elevators	No			CHANGE IN ELEVATION		
Interior Lobby Doors And Hardware		Yes				
Interior Ramps	Yes	Yes				

Rooms & Spaces

Art Rooms	No					
Auditorium						
1st Floor	Yes	Yes			FM System	Yes
Cafeteria						
1st Floor	Yes	Yes			FM System	Yes
Classrooms						
1st Floor	Yes	Yes				
Computer Rooms	No					
Gymnasium						
3rd Floor	Yes	No			FM System	Yes

NOT ON ACCESSIBLE
ROUTE

Library

**NYC Department of Education
Building Condition Assessment Survey 2023-2024**

Architectural Inspection

M015

Physical Breakdown Structure	Exists	Complies	Required	Deficiency	Assistive Listening System	Fire Alarm Strobe
Room 308/310	Yes	No		NOT ON ACCESSIBLE ROUTE		
Main Office						
Rooms 205 (P.S. 15) and Room 505 (M094 SPED)	Yes	No		NOT ON ACCESSIBLE ROUTE		
Multi-purpose Room	No					
Nurse's Office						
Room 102/104	Yes	Yes				
Pool	No					
Science Lab	No					
Toilet Rooms (boys)						
1st Floor	Yes	Yes				
Toilet Rooms (girls)						
1st Floor	Yes	Yes				
Toilet Rooms (staff)						
1st Floor Men's and Women's	Yes	No		CLEAR OPENING < 32" WATER CLOSET ARRANGEMENT TURNING RADIUS SINK ARRANGEMENT ACCESSORY ARRANGEMENT		

Building Template

M015

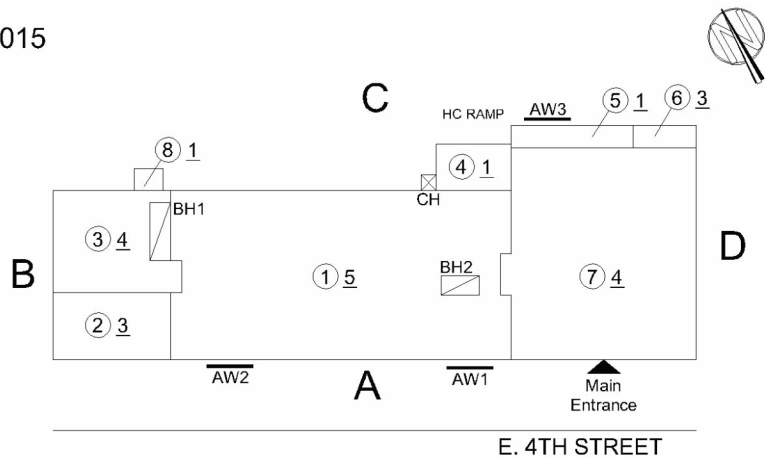

Inspection

Question	Response
Architectural	
EXTERIOR	Inspected
AREAWAY	Inspected
Instance on AW1-AW3	Inspected

**NYC Department of Education
Building Condition Assessment Survey 2023-2024**

Architectural Inspection

M015

Question	Response
----------	----------

EXTERIOR

AREAWAY

Instance Condition	2- Between Good and Fair
Instance Quantity	3
Instance Quantity Uom	EACH
Deficiency	No deficiencies recorded

AWNINGS AND CANOPIES

Condition	2- Between Good and Fair
-----------	--------------------------

Deficiency	CONCRETE:DETERIORATED
------------	-----------------------

Deficiency Location/Instance

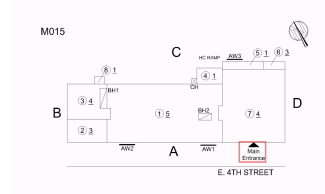

Deficiency Quantity	5
Quantity Uom	S.F.
Potential Action	REPLACE
Urgency of Action	PRIORITY 3
Purpose of Action	LEVEL 2
Deficiency Photo 1	



Main Entrance	No photo recorded
Deficiency Photo 2	No photo recorded
Violations	No violations recorded

CHIMNEY

Material Type(s)	Masonry
------------------	---------

Condition	3- Fair
-----------	---------

Deficiency	BRICK:DETERIORATED JOINTS
------------	---------------------------

Deficiency Location/Instance

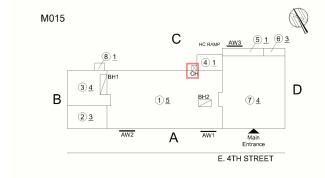

Deficiency Quantity	25
Quantity Uom	S.F.
Potential Action	REPOINT
Urgency of Action	PRIORITY 3
Purpose of Action	LEVEL 2
Deficiency Photo 1	

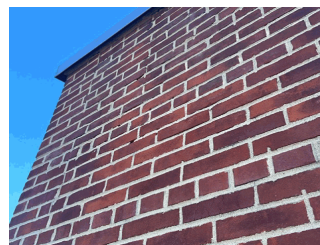

**NYC Department of Education
Building Condition Assessment Survey 2023-2024**

Architectural Inspection

M015

Question	Response
----------	----------

EXTERIOR

CHIMNEY

Deficiency Photo 2
Violations
Deficiency
Deficiency Location/Instance

Chimney CH
No photo recorded
No violations recorded
BRICK:MINOR CRACKS, SPALLING

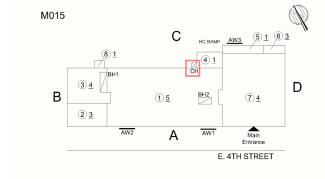

Deficiency Quantity
Quantity Uom
Potential Action
Urgency of Action
Purpose of Action
Deficiency Photo 1

10
S.F.
RESTITCH
PRIORITY 3
LEVEL 2



Deficiency Photo 2
Violations

Chimney CH
No photo recorded
No violations recorded

COPING

Condition

Deficiency
Deficiency Location/Instance

Inspected
3- Fair
CAST STONE:CRACKED/BROKEN PIECES

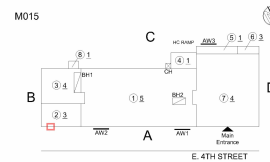

Deficiency Quantity
Quantity Uom
Potential Action
Urgency of Action
Purpose of Action
Deficiency Photo 1

15
L.F.
REPLACE-IN-KIND
PRIORITY 3
LEVEL 2



Deficiency Photo 2
Violations

Roof 2
No photo recorded
No violations recorded

Deficiency

CAST STONE:DETERIORATED BED JOINT

**NYC Department of Education
Building Condition Assessment Survey 2023-2024**

Architectural Inspection

M015

Question	Response
----------	----------

EXTERIOR

COPING

Deficiency Location/Instance

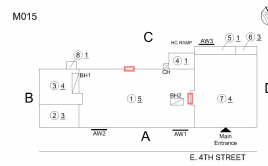

Deficiency Quantity
Quantity Uom
Potential Action
Urgency of Action
Purpose of Action
Deficiency Photo 1

20
L.F.
REPOINT
PRIORITY 3
LEVEL 2



Roof 1 - Facade C

Deficiency Photo 2
Violations

No photo recorded
No violations recorded

CORNICE

Condition

Inspected

Deficiency

2- Between Good and Fair

No deficiencies recorded

DOORS

DOORS AND FRAMES

Condition

Inspected

Deficiency

Inspected

3- Fair

METAL:DETERIORATED DOOR AND FRAME - MINOR DETERIORATION

Deficiency Location/Instance

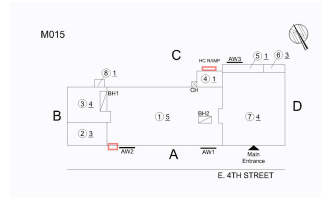

Deficiency Quantity
Quantity Uom
Potential Action
Urgency of Action
Purpose of Action
Deficiency Photo 1

4
EACH
MAINTENANCE
PRIORITY 3
LEVEL 2



Exit 5

Deficiency Photo 2
Violations

No photo recorded
No violations recorded

**NYC Department of Education
Building Condition Assessment Survey 2023-2024**

Architectural Inspection

M015

Question	Response
----------	----------

EXTERIOR

DOORS

DOORS AND FRAMES

Deficiency

METAL:DETERIORATED DOOR AND FRAME - MAJOR DETERIORATION

Deficiency Location/Instance

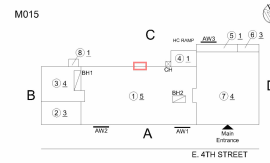

Deficiency Quantity
Quantity Uom
Potential Action
Urgency of Action
Purpose of Action
Deficiency Photo 1

2
EACH
REPLACE
PRIORITY 4
LEVEL 2



Deficiency Photo 2
Violations

Exit 4
No photo recorded
No violations recorded

DOOR HARDWARE

Condition

Inspected

Deficiency

3- Fair

LINTELS

Condition

Inspected

Deficiency

2- Between Good and Fair

TRANSOM/SIDE LIGHT

Condition

Inspected

Deficiency

2- Between Good and Fair

EXTERIOR WALLS

Material Type(s)

Inspected

Replacement Quantity

Masonry

Replacement Uom

35,000

Instance on All Facades

S.F.

Instance Condition

Inspected

Instance Quantity

3- Fair

Instance Quantity Uom

35,000

Deficiency

S.F.

Roof Plan Reference

BRICK:DETERIORATED JOINTS

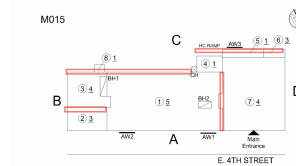

**NYC Department of Education
Building Condition Assessment Survey 2023-2024**

Architectural Inspection

M015

Question

Response

EXTERIOR

EXTERIOR WALLS

Elevation



Elevation Reference
Deficiency Quantity
Quantity Uom
Potential Action
Urgency of Action
Purpose of Action
Deficiency Photo 1

All Facades
500
S.F.
REPOINT
PRIORITY 3
LEVEL 2



Facade C

Deficiency Photo 2
Violations

No photo recorded
No violations recorded

Deficiency

Roof Plan Reference

BRICK:DETERIORATED MASONRY SILLS - MAJOR

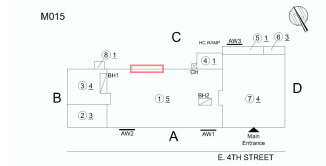

Elevation



Elevation Reference
Deficiency Quantity
Quantity Uom
Potential Action
Urgency of Action
Purpose of Action
Deficiency Photo 1

Facade C
20
L.F.
REMOVE AND REPLACE
PRIORITY 4
LEVEL 2



Facade C

Deficiency Photo 2

No photo recorded

**NYC Department of Education
Building Condition Assessment Survey 2023-2024**

Architectural Inspection

M015

Question

Response

EXTERIOR

EXTERIOR WALLS

Violations

No violations recorded

Deficiency

STUCCO CEMENT SURFACE:CRACKS, SPALLING

Roof Plan Reference

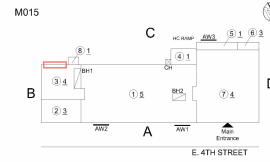

Elevation

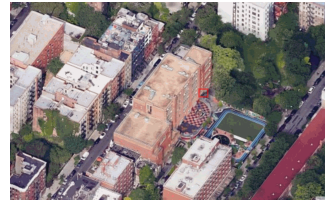

Elevation Reference

Facade C

Deficiency Quantity

50

Quantity Uom

S.F.

Potential Action

REPLACE

Urgency of Action

PRIORITY 4

Purpose of Action

LEVEL 2

Deficiency Photo 1



Deficiency Photo 2

Facade C

Violations

No photo recorded

Deficiency

No violations recorded

Roof Plan Reference

BRICK:DETERIORATED CONTROL/EXPANSION JOINTS WITH DAMAGED CAULKING

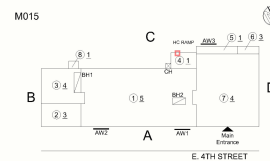

Elevation

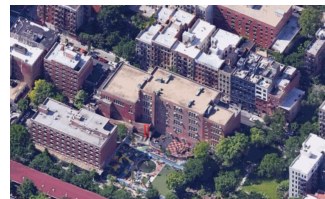

Elevation Reference

Facade C

Deficiency Quantity

10

Quantity Uom

L.F.

Potential Action

MAINTENANCE

Urgency of Action

PRIORITY 3



Purpose of Action

LEVEL 2

**NYC Department of Education
Building Condition Assessment Survey 2023-2024**

Architectural Inspection

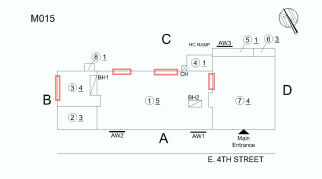
M015

Question	Response
EXTERIOR	
EXTERIOR WALLS	
Deficiency Photo 1	
Deficiency Photo 2	Facade C
Violations	No photo recorded No violations recorded
EXTERIOR SOFFITS	Inspected
Condition	2- Between Good and Fair
Deficiency	No deficiencies recorded
LOADING DOCK	Does not exist
LOUVER	Inspected
Condition	2- Between Good and Fair
Deficiency	No deficiencies recorded
PARAPETS	Inspected
Material Type(s)	Masonry
Replacement Quantity	5,500
Replacement Uom	C.F.
Instance on All Facades	Inspected
Instance Condition	3- Fair
Instance Quantity	5,500
Instance Quantity Uom	CF
Deficiency	BRICK:DETERIORATED JOINTS
Deficiency Location/Instance	
Deficiency Quantity	75
Quantity Uom	S.F.
Potential Action	REPOINT
Urgency of Action	PRIORITY 3
Purpose of Action	LEVEL 2
Deficiency Photo 1	
Deficiency Photo 2	Roof 1 - Facade C
Violations	No photo recorded No violations recorded
Deficiency	BRICK:MINOR CRACKS, SPALLING

**NYC Department of Education
Building Condition Assessment Survey 2023-2024**

Architectural Inspection

M015

Question	Response
----------	----------

EXTERIOR

PARAPETS

Deficiency Location/Instance

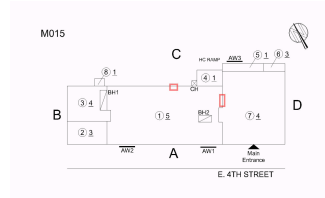

Deficiency Quantity

10

Quantity Uom

S.F.

Potential Action

REPAIR

Urgency of Action

PRIORITY 3

Purpose of Action

LEVEL 2

Deficiency Photo 1



Deficiency Photo 2

Roof 1

Violations

No photo recorded

No violations recorded

PLAZA DECK

Inspected

Instance on Pavers:Roof 2

Inspected

Instance Condition

2- Between Good and Fair

Instance Quantity

900

Instance Quantity Uom

S.F.

Installation Year

2008

Source of Installation Year

Documented

Deficiency

No deficiencies recorded

ROOF

Inspected

ROOFING

Inspected

ROOF HATCH/SMOKE HATCH

Does not exist

LEADERS, GUTTERS, DOWNSPOUTS, SCUPPERS

Inspected

Condition

2- Between Good and Fair

Deficiency

No deficiencies recorded

ROOF BARRIER/FENCE

Inspected

Condition

2- Between Good and Fair

Deficiency

No deficiencies recorded

ROOF CAGE

Does not exist

ROOFING

Inspected

Replacement Quantity

14,400

Replacement Uom

S.F.

Instance on Built-Up:All Roofs except Roof 2

Inspected

Instance Roof Photo



Roof 1

**NYC Department of Education
Building Condition Assessment Survey 2023-2024**

Architectural Inspection

M015

Question	Response
----------	----------

EXTERIOR

ROOF

ROOFING

ROOFING

Instance Condition	3- Fair
Instance Quantity	14,400
Instance Quantity Uom	S.F.
Does the roof have major mechanical equipment sitting on Dunnage Steel less than 18" above the Roofing?	No
Does this Roof Instance have a Sustainable Roof System?	No
Do solar panels exist on these roofs?	No
Is/Are the roof(s) suitable for Solar Panel installation?	No
Installation Year	2008
Source of Installation Year	Documented
Deficiency	BUILT-UP:FLASHING:BASE FLASHING DETERIORATED
Deficiency Location/Instance	

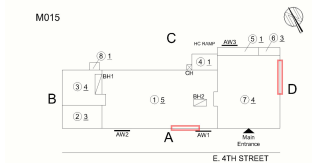

Deficiency Quantity	30
Quantity Uom	S.F.
Potential Action	REMOVE AND REPLACE
Urgency of Action	PRIORITY 4
Purpose of Action	LEVEL 2
Deficiency Photo 1	



Roof 1 - Facade A

Deficiency Photo 2	No photo recorded
Violations	No violations recorded

ROOFING DRAINS

Condition	Inspected
Deficiency	2- Between Good and Fair
	No deficiencies recorded

SPECIALTIES

BULKHEAD/PENTHOUSE

Condition	Inspected
Deficiency	3- Fair
	BULKHEAD/PENTHOUSE WALLS/EXTERIOR:DETERIORATED JOINTS
Deficiency Location/Instance	

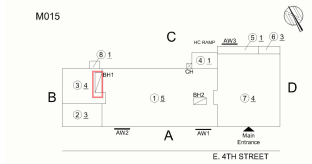



Deficiency Quantity	100
Quantity Uom	S.F.
Potential Action	REPOINT
Urgency of Action	PRIORITY 3

**NYC Department of Education
Building Condition Assessment Survey 2023-2024**

Architectural Inspection

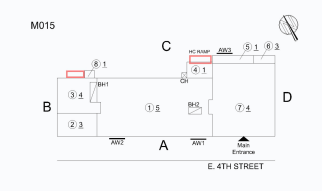
M015

Question	Response
EXTERIOR	
ROOF	
SPECIALTIES	
BULKHEAD/PENTHOUSE	
Purpose of Action	LEVEL 2
Deficiency Photo 1	
Deficiency Photo 2	Bulkhead BH1
Violations	No photo recorded No violations recorded
CUPOLA/ SPIRES/ TOWERS	Does not exist
DORMER	Does not exist
DUNNAGE STEEL	Does not exist
SKYLIGHT/ROOF VENT	Does not exist
ROOF/GRAVITY TANK	Does not exist
STAIRS/RAMPS: EXTERIOR	Inspected
BUILDING CHEEK/FLANK WALLS	Inspected
Condition	3- Fair
Deficiency	CAST IN PLACE CONCRETE:CRACKS/SPALLING - MINOR
Deficiency Location/Instance	
Deficiency Quantity	15
Quantity Uom	S.F.
Potential Action	REPAIR
Urgency of Action	PRIORITY 3
Purpose of Action	LEVEL 2
Deficiency Photo 1	
Deficiency Photo 2	Exit 5
Violations	No photo recorded No violations recorded
RAILINGS	Inspected
Condition	4- Between Fair and Poor
Deficiency	RUST - MAJOR

**NYC Department of Education
Building Condition Assessment Survey 2023-2024**

Architectural Inspection

M015

Question	Response
----------	----------

EXTERIOR

STAIRS/RAMPS: EXTERIOR

RAILINGS

Deficiency Location/Instance

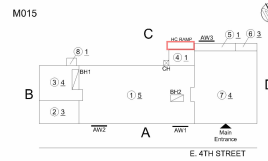

Deficiency Quantity
Quantity Uom
Potential Action
Urgency of Action
Purpose of Action
Deficiency Photo 1

20
L.F.
REPLACE
PRIORITY 4
LEVEL 2



Deficiency Photo 2
Violations

Exit 5
No photo recorded
No violations recorded

STAIRS/RAMPS

Condition

Deficiency

Deficiency Location/Instance

Inspected
4- Between Fair and Poor

CONCRETE:WORN-OUT TREAD/RISER/NOSING

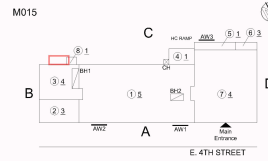

Deficiency Quantity
Quantity Uom
Potential Action
Urgency of Action
Purpose of Action
Deficiency Photo 1

10
S.F.
REPLACE
PRIORITY 4
LEVEL 2



Deficiency Photo 2
Violations

Exit 3
No photo recorded
No violations recorded

Deficiency

CONCRETE:CRACKS/SPALLING - MAJOR

**NYC Department of Education
Building Condition Assessment Survey 2023-2024**

Architectural Inspection

M015

Question

Response

EXTERIOR

STAIRS/RAMPS: EXTERIOR

STAIRS/RAMPS

Deficiency Location/Instance

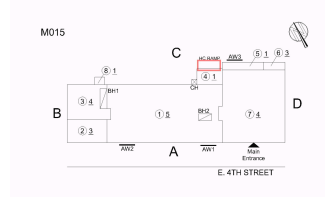

Deficiency Quantity

10

Quantity Uom

S.F.

Potential Action

REPLACE

Urgency of Action

PRIORITY 4

Purpose of Action

LEVEL 2

Deficiency Photo 1



Deficiency Photo 2

Exit 5

Violations

No photo recorded

No violations recorded

Deficiency

CONCRETE:CRACKS/SPALLING - MINOR

Deficiency Location/Instance

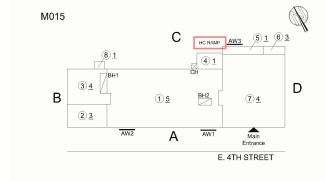

Deficiency Quantity

15

Quantity Uom

S.F.

Potential Action

REPAIR

Urgency of Action

PRIORITY 3

Purpose of Action

LEVEL 2

Deficiency Photo 1



Deficiency Photo 2

HC Ramp at Exit 5

Violations

No photo recorded

No violations recorded

WINDOWS

Replacement Quantity

Inspected

Replacement Uom

11,000

S.F.

EXTERIOR GUARDS

Condition

Inspected

Deficiency

2- Between Good and Fair

No deficiencies recorded

**NYC Department of Education
Building Condition Assessment Survey 2023-2024**

Architectural Inspection



M015

Question	Response
EXTERIOR	
WINDOWS	
LINTELS	Inspected
Condition	2- Between Good and Fair
Deficiency	No deficiencies recorded
WINDOWS	Inspected
Material Type(s)	Aluminum
Instance on Aluminum - Double Hung:All Facades	Inspected
Instance Condition	3- Fair
Instance Quantity	10,900
Instance Quantity Uom	S.F.
Installation Year	2000
Source of Installation Year	Documented
Are these windows insulated?	No
Deficiency	No deficiencies recorded
Instance on Aluminum - Other:Basement	Inspected
Instance Condition	3- Fair
Instance Quantity	100
Instance Quantity Uom	S.F.
Installation Year	2000
Source of Installation Year	Documented
Are these windows insulated?	No
Deficiency	No deficiencies recorded
INTERIOR	Inspected
POOLS	Does not exist
STRUCTURAL	Inspected
COLUMNS/BEAMS/BEARING WALLS	Inspected
Condition	3- Fair
Deficiency	MASONRY BEARING WALL:CRACKED/SPALLED
Deficiency Location/Instance	Basement and 1st Floor
Deficiency Quantity	5
Quantity Uom	S.F.
Potential Action	RESTITCH
Urgency of Action	PRIORITY 3
Purpose of Action	LEVEL 5
Deficiency Photo 1	
Deficiency Photo 2	No photo recorded
Violations	No violations recorded
Deficiency	STEEL COLUMNS/BEAMS:DETERIORATED/MISSING SPRAY-ON FIREPROOFING
Deficiency Location/Instance	Basement
Deficiency Quantity	40
Quantity Uom	S.F.
Potential Action	REPLACE
Urgency of Action	PRIORITY 3
Purpose of Action	LEVEL 5

**NYC Department of Education
Building Condition Assessment Survey 2023-2024**

Architectural Inspection



M015

Question	Response
INTERIOR	
STRUCTURAL	
COLUMNS/BEAMS/BEARING WALLS	
Deficiency Photo 1	
Deficiency Photo 2	Electrical Panel Room shown, also Storage Room
Violations	No photo recorded No violations recorded
FLOOR STRUCTURE	
Condition	Inspected
Deficiency	3- Fair
Deficiency Location/Instance	CINDER CONCRETE ARCH:METAL PAN DETERIORATED, SPALLED
Deficiency Quantity	Basement
Quantity Uom	20
Potential Action	S.F.
Urgency of Action	REPAIR
Purpose of Action	PRIORITY 3
Deficiency Photo 1	LEVEL 5
	
Deficiency Photo 2	Boiler Room
Violations	No photo recorded No violations recorded
FOUNDATION WALLS	
Material Type(s)	Inspected
Condition	Masonry
Deficiency	3- Fair
Deficiency Location/Instance	BRICK:WATER INFILTRATION IN NON-INSTRUCTIONAL SPACE
Deficiency Quantity	Basement
Quantity Uom	100
Potential Action	S.F.
Urgency of Action	INSTALL WATERPROOFING
Purpose of Action	PRIORITY 5
Deficiency Photo 1	LEVEL 5
	
Deficiency Photo 2	Water Main Room
	No photo recorded

**NYC Department of Education
Building Condition Assessment Survey 2023-2024**

Architectural Inspection



M015

Question	Response
INTERIOR	
STRUCTURAL	
FOUNDATION WALLS	
Violations	No violations recorded
Deficiency	BRICK:WATER INFILTRATION IN ELECTRICAL PANEL ROOM
Deficiency Location/Instance	Basement
Deficiency Quantity	50
Quantity Uom	S.F.
Potential Action	INSTALL WATERPROOFING
Urgency of Action	PRIORITY 5
Purpose of Action	LEVEL 6
Deficiency Photo 1	
Deficiency Photo 2	Electrical Panel Room
Violations	No photo recorded
Violations	No violations recorded
Deficiency	BRICK:DETERIORATED JOINTS
Deficiency Location/Instance	Basement
Deficiency Quantity	100
Quantity Uom	S.F.
Potential Action	REPOINT
Urgency of Action	PRIORITY 3
Purpose of Action	LEVEL 5
Deficiency Photo 1	
Deficiency Photo 2	Storage Area
Violations	No photo recorded
Violations	No violations recorded
ROOF STRUCTURE	
Condition	Inspected
Condition	2- Between Good and Fair
Deficiency	No deficiencies recorded
VAULTS-BUNKERS	
Condition	Inspected
Condition	Inspected
Condition	3- Fair
Deficiency	Deteriorated Joints
Deficiency Location/Instance	Basement
Deficiency Quantity	50
Quantity Uom	S.F.
Potential Action	REPOINT
Urgency of Action	PRIORITY 3
Purpose of Action	LEVEL 5

**NYC Department of Education
Building Condition Assessment Survey 2023-2024**

Architectural Inspection

M015

Question	Response
INTERIOR	
STRUCTURAL	
VAULTS-BUNKERS	
Foundation Walls	
Deficiency Photo 1	
Deficiency Photo 2	Ash Hoist Vault
Violations	No photo recorded
	No violations recorded
Slab Structure	Inspected
Condition	2- Between Good and Fair
Deficiency	No deficiencies recorded
Vault/Ash Hoist Doors and Framing	Inspected
Condition	5- Poor
Deficiency	WATER INFILTRATION
Deficiency Location/Instance	Basement
Deficiency Quantity	10
Quantity Uom	S.F.
Potential Action	REPAIR
Urgency of Action	PRIORITY 5
Purpose of Action	LEVEL 2
Deficiency Photo 1	
Deficiency Photo 2	Ash Hoist Vault
Violations	No photo recorded
	No violations recorded
AUDITORIUM	Inspected
Instance on 1st Floor (324 Seats)	Inspected
Ceiling	Inspected
Instance on 1st Floor (324 Seats)	Inspected
Instance Condition	2- Between Good and Fair
Deficiency	No deficiencies recorded
Door(s)	Inspected
Instance on 1st Floor (324 Seats)	Inspected
Instance Condition	2- Between Good and Fair
Deficiency	No deficiencies recorded
Fixed H/C Lift	Inspected
Instance on 1st Floor (324 Seats)	Inspected
Instance Condition	2- Between Good and Fair
Deficiency	No deficiencies recorded
Fixed Seating	Inspected
Instance on 1st Floor (324 Seats)	Inspected
Instance Condition	5- Poor

**NYC Department of Education
Building Condition Assessment Survey 2023-2024**

Architectural Inspection

M015

Question	Response
INTERIOR	
AUDITORIUM	
Fixed Seating	
Deficiency	DAMAGED/BROKEN/INOPERABLE
Deficiency Location/Instance	Seats B/1,9, D/5, E/1, F/1 and others
Deficiency Quantity	35
Quantity Uom	EACH
Potential Action	REPLACE
Urgency of Action	PRIORITY 3
Purpose of Action	LEVEL 2
Deficiency Photo 1	
Deficiency Photo 2	Seat B/1 No photo recorded
Violations	No violations recorded
Floor Finish	
Instance on 1st Floor (324 Seats)	Inspected
Instance Condition	2- Between Good and Fair
Deficiency	SHEET VINYL:BROKEN/DETERIORATED/MISSING TILES
Deficiency Location/Instance	Near Entrance, near front
Deficiency Quantity	50
Quantity Uom	S.F.
Potential Action	REPLACE
Urgency of Action	PRIORITY 3
Purpose of Action	LEVEL 2
Deficiency Photo 1	
Deficiency Photo 2	Near Entrance No photo recorded
Violations	No violations recorded
Sliding-folding Partition	
Instance on 1st Floor (324 Seats)	Does not exist
Stage	
Instance on 1st Floor (324 Seats)	Inspected
Stage	
Instance on 1st Floor (324 Seats)	Inspected
Instance Condition	2- Between Good and Fair
Deficiency	No deficiencies recorded
Stage Curtain Rigging	
Instance on 1st Floor (324 Seats)	Inspected
Instance Condition	2- Between Good and Fair
Deficiency	No deficiencies recorded
Stage Curtains	

**NYC Department of Education
Building Condition Assessment Survey 2023-2024**

Architectural Inspection

M015

Question	Response
INTERIOR	
AUDITORIUM	
Stage	
Stage Curtains	
Instance on 1st Floor (324 Seats)	Inspected
Instance Condition	2- Between Good and Fair
Deficiency	No deficiencies recorded
Walls	
Instance on 1st Floor (324 Seats)	Inspected
Instance Condition	2- Between Good and Fair
Deficiency	No deficiencies recorded
Window Curtains/Shades/Blinds	
Instance on 1st Floor (324 Seats)	Does not exist
CAFETERIA	
Instance on 1st Floor	Inspected
Instance on 1st Floor	Inspected
Ceiling	
Instance on 1st Floor	Inspected
Instance Condition	2- Between Good and Fair
Deficiency	No deficiencies recorded
Door(s)	
Instance on 1st Floor	Inspected
Instance Condition	5- Poor
Deficiency	WOOD:DETERIORATED DOOR
Deficiency Location/Instance	Entrance
Deficiency Quantity	2
Quantity Uom	EACH
Potential Action	MAINTENANCE
Urgency of Action	PRIORITY 3
Purpose of Action	LEVEL 2
Deficiency Photo 1	
Deficiency Photo 2	No photo recorded
Violations	No violations recorded
Deficiency	METAL:DETERIORATED DOOR
Deficiency Location/Instance	Main Entry Door
Deficiency Quantity	1
Quantity Uom	EACH
Potential Action	MAINTENANCE
Urgency of Action	PRIORITY 3
Purpose of Action	LEVEL 2
Deficiency Photo 1	

**NYC Department of Education
Building Condition Assessment Survey 2023-2024**

Architectural Inspection

M015

Question	Response
INTERIOR	
CAFETERIA	
Door(s)	Main Entry Door
Deficiency Photo 2	No photo recorded
Violations	No violations recorded
Fixed Equipment	
Instance on 1st Floor	Does not exist
Floor Finish	
Instance on 1st Floor	Inspected
Instance Condition	2- Between Good and Fair
Deficiency	No deficiencies recorded
Sliding-folding Partition	
Instance on 1st Floor	Does not exist
Stage	
Instance on 1st Floor	Does not exist
Walls	
Instance on 1st Floor	Inspected
Instance Condition	2- Between Good and Fair
Deficiency	No deficiencies recorded
Window Curtains/Shades/Blinds	
Instance on 1st Floor	Does not exist
CLASSROOMS/CORRIDORS/ADMIN SPACES	Inspected
Ceiling	Inspected
Condition	2- Between Good and Fair
Deficiency	No deficiencies recorded
Door(s)	Inspected
Condition	5- Poor
Deficiency	WOOD:DETERIORATED DOOR
Deficiency Location/Instance	Exit Vestibule 2, Rooms 202, 312, 505, 512
Deficiency Quantity	10
Quantity Uom	EACH
Potential Action	MAINTENANCE
Urgency of Action	PRIORITY 3
Purpose of Action	LEVEL 2
Deficiency Photo 1	
	Room 512
Deficiency Photo 2	No photo recorded
Violations	No violations recorded
Deficiency	WOOD:MISSING DOOR
Deficiency Location/Instance	Rooms 117, 204
Deficiency Quantity	2
Quantity Uom	EACH
Potential Action	MAINTENANCE
Urgency of Action	PRIORITY 3
Purpose of Action	LEVEL 2

**NYC Department of Education
Building Condition Assessment Survey 2023-2024**

Architectural Inspection

M015

Question	Response
INTERIOR	
CLASSROOMS/CORRIDORS/ADMIN SPACES	
Door(s)	
Deficiency Photo 1	
Deficiency Photo 2	Room 117
Violations	No photo recorded No violations recorded
Floor Finish	Inspected
Condition	4- Between Fair and Poor
Deficiency	TERRAZZO:CRACKS
Deficiency Location/Instance	Main Entrance Lobby
Deficiency Quantity	50
Quantity Uom	S.F.
Potential Action	REPLACE
Urgency of Action	PRIORITY 3
Purpose of Action	LEVEL 2
Deficiency Photo 1	
Deficiency Photo 2	Main Entrance Lobby
Violations	No photo recorded No violations recorded
Deficiency	VINYL TILES:BROKEN/DETERIORATED/MISSING TILES
Deficiency Location/Instance	Rooms 212, 303, 307, 407, 508 and others
Deficiency Quantity	2,000
Quantity Uom	S.F.
Potential Action	REPLACE
Urgency of Action	PRIORITY 3
Purpose of Action	LEVEL 2
Deficiency Photo 1	
Deficiency Photo 2	Room 508
Violations	No photo recorded No violations recorded
Deficiency	VINYL TILES:DETERIORATED SUBSTRATE
Deficiency Location/Instance	Rooms 205, 212, 403, 508, Corridor near Room 215 and others
Deficiency Quantity	600
Quantity Uom	S.F.

**NYC Department of Education
Building Condition Assessment Survey 2023-2024**

Architectural Inspection



M015

Question	Response
INTERIOR	
CLASSROOMS/CORRIDORS/ADMIN SPACES	
Floor Finish	
Potential Action	REPLACE
Urgency of Action	PRIORITY 3
Purpose of Action	LEVEL 2
Deficiency Photo 1	
Deficiency Photo 2	Room 205
Violations	No photo recorded No violations recorded
Walls	Inspected
Condition	2- Between Good and Fair
Deficiency	PLASTER:CRACKS/SPALLING
Deficiency Location/Instance	Rooms 103, Corridor near Room 203, 303, 307, 505 and others
Deficiency Quantity	90
Quantity Uom	S.F.
Potential Action	REPLACE
Urgency of Action	PRIORITY 3
Purpose of Action	LEVEL 2
Deficiency Photo 1	
Deficiency Photo 2	Corridor near Room 505
Violations	No photo recorded No violations recorded
Specialties	Does not exist
GYMNASIUM	Inspected
Instance on 3rd Floor	Inspected
Ceiling	
Instance on 3rd Floor	Inspected
Instance Condition	2- Between Good and Fair
Deficiency	No deficiencies recorded
Door(s)	
Instance on 3rd Floor	Inspected
Instance Condition	2- Between Good and Fair
Deficiency	No deficiencies recorded
Fixed Equipment	
Instance on 3rd Floor	Inspected
Instance Condition	2- Between Good and Fair
Deficiency	No deficiencies recorded
Floor Finish	
Instance on 3rd Floor	Inspected
Instance Condition	2- Between Good and Fair

**NYC Department of Education
Building Condition Assessment Survey 2023-2024**

Architectural Inspection



M015

Question	Response
INTERIOR	
GYMNASIUM	
Floor Finish	
Deficiency	WOOD:DAMAGED/DETERIORATED
Deficiency Location/Instance	Near Entrance, near office
Deficiency Quantity	20
Quantity Uom	S.F.
Potential Action	REPLACE
Urgency of Action	PRIORITY 3
Purpose of Action	LEVEL 2
Deficiency Photo 1	
Deficiency Photo 2	Near Entrance No photo recorded
Violations	No violations recorded
Seating	
Instance on 3rd Floor	Does not exist
Sliding-folding Partition	
Instance on 3rd Floor	Does not exist
Stage	
Instance on 3rd Floor	Does not exist
Walls	
Instance on 3rd Floor	Inspected
Instance Condition	3- Fair
Deficiency	MASONRY:CRACKS/SPALLING
Deficiency Location/Instance	Perimeter, Near Entrance
Deficiency Quantity	275
Quantity Uom	S.F.
Potential Action	REPLACE
Urgency of Action	PRIORITY 4
Purpose of Action	LEVEL 4
Deficiency Photo 1	
Deficiency Photo 2	Near Entrance No photo recorded
Violations	35655131P
Deficiency	GLAZED BLOCK:CRACKS/SPALLING
Deficiency Location/Instance	Near Drinking Fountain
Deficiency Quantity	10
Quantity Uom	S.F.
Potential Action	REPLACE
Urgency of Action	PRIORITY 3
Purpose of Action	LEVEL 2

**NYC Department of Education
Building Condition Assessment Survey 2023-2024**

Architectural Inspection

M015

Question	Response
INTERIOR	
GYMNASIUM	
Walls	
Deficiency Photo 1	
Deficiency Photo 2	Near Drinking Fountain
Violations	No photo recorded No violations recorded
Window Curtains/Shades/Blinds	
Instance on 3rd Floor	Does not exist
INTERIOR DOOR HARDWARE	
Condition	Inspected
Deficiency	3- Fair No deficiencies recorded
INTERIOR GUARDS	
Condition	Inspected
Deficiency	2- Between Good and Fair No deficiencies recorded
KITCHEN	
Instance on 1st Floor	Inspected
Ceiling	
Instance on 1st Floor	Inspected
Instance Condition	2- Between Good and Fair
Deficiency	No deficiencies recorded
Door(s)	
Instance on 1st Floor	Inspected
Instance Condition	4- Between Fair and Poor
Deficiency	WOOD:DETERIORATED DOOR
Deficiency Location/Instance	Main Entrance , office
Deficiency Quantity	2
Quantity Uom	EACH
Potential Action	MAINTENANCE
Urgency of Action	PRIORITY 3
Purpose of Action	LEVEL 2
Deficiency Photo 1	
Deficiency Photo 2	Office
Violations	No photo recorded No violations recorded
Floor Finish	
Instance on 1st Floor	Inspected
Instance Condition	2- Between Good and Fair
Deficiency	CERAMIC TILE:BROKEN/MISSING TILES
Deficiency Location/Instance	Center
Deficiency Quantity	10

**NYC Department of Education
Building Condition Assessment Survey 2023-2024**

Architectural Inspection

M015

Question	Response
INTERIOR	
KITCHEN	
Floor Finish	
Quantity Uom	S.F.
Potential Action	REPLACE
Urgency of Action	PRIORITY 3
Purpose of Action	LEVEL 2
Deficiency Photo 1	
Deficiency Photo 2	Center
Violations	No photo recorded No violations recorded
Walls	
Instance on 1st Floor	Inspected
Instance Condition	2- Between Good and Fair
Deficiency	No deficiencies recorded
LIBRARY	
Instance on Room 308/310	Inspected
Built-in Furnishing	
Instance on Room 308/310	Does not exist
Ceiling	
Instance on Room 308/310	Inspected
Instance Condition	2- Between Good and Fair
Deficiency	No deficiencies recorded
Door(s)	
Instance on Room 308/310	Inspected
Instance Condition	2- Between Good and Fair
Deficiency	No deficiencies recorded
Floor Finish	
Instance on Room 308/310	Inspected
Instance Condition	5- Poor
Deficiency	CARPET:WORN/DETERIORATED
Deficiency Location/Instance	Center
Deficiency Quantity	75
Quantity Uom	S.F.
Potential Action	REPLACE
Urgency of Action	PRIORITY 3
Purpose of Action	LEVEL 2
Deficiency Photo 1	
Deficiency Photo 2	Center
Violations	No photo recorded No violations recorded

**NYC Department of Education
Building Condition Assessment Survey 2023-2024**

Architectural Inspection

M015

Question	Response
INTERIOR	
LIBRARY	
Floor Finish	
Deficiency	VINYL TILES:DETERIORATED SUBSTRATE
Deficiency Location/Instance	Center
Deficiency Quantity	50
Quantity Uom	S.F.
Potential Action	REPLACE
Urgency of Action	PRIORITY 3
Purpose of Action	LEVEL 2
Deficiency Photo 1	
Deficiency Photo 2	Center
Violations	No photo recorded No violations recorded
Walls	
Instance on Room 308/310	Inspected
Instance Condition	2- Between Good and Fair
Deficiency	No deficiencies recorded
LOCKER ROOM	
Instance on 3rd Floor inside Gymnasium (52 Lockers)	Inspected
Instance on Room 417 - Girls	Inaccessible
MULTI-PURPOSE ROOM	
Instance	Does not exist
SCIENCE DEMO ROOM	
Instance	Does not exist
SCIENCE LAB	
Instance	Does not exist
SCIENCE PREP ROOM	
Instance	Does not exist
SHOWER ROOM	
Instance on Room 417 - Girls	Inspected
Instance on 3rd Floor inside Gymnasium	Inaccessible
STAIRS/RAMPS: INTERIOR	
Do Letter Stair Signs Exist?	Inspected Yes
Ceiling	
Condition	Inspected 2- Between Good and Fair
Deficiency	No deficiencies recorded
Door(s)	
Condition	Inspected 2- Between Good and Fair
Deficiency	No deficiencies recorded
Partition	
Condition	Inspected 2- Between Good and Fair
Deficiency	GLASS PANEL:DAMAGED/DETERIORATED
Deficiency Location/Instance	Stair CD/1-4
Deficiency Quantity	25
Quantity Uom	S.F.
Potential Action	REPLACE
Urgency of Action	PRIORITY 3
Purpose of Action	LEVEL 2

**NYC Department of Education
Building Condition Assessment Survey 2023-2024**

Architectural Inspection

M015

Question	Response
INTERIOR	
STAIRS/RAMPS: INTERIOR	
Partition	
Deficiency Photo 1	
Deficiency Photo 2	Stair CD/1
Violations	No photo recorded No violations recorded
Railings	Inspected
Condition	2- Between Good and Fair
Deficiency	No deficiencies recorded
Stairs and Landings	Inspected
Condition	2- Between Good and Fair
Deficiency	METAL:RUST - MAJOR
Deficiency Location/Instance	Stair AB/4
Deficiency Quantity	10
Quantity Uom	S.F.
Potential Action	REPLACE
Urgency of Action	PRIORITY 3
Purpose of Action	LEVEL 2
Deficiency Photo 1	
Deficiency Photo 2	Stair AB/4
Violations	No photo recorded No violations recorded
Deficiency	VINYL TILES:BROKEN/DETERIORATED/MISSING TILES
Deficiency Location/Instance	Stair AB/1,2, CD/5
Deficiency Quantity	30
Quantity Uom	S.F.
Potential Action	REPLACE
Urgency of Action	PRIORITY 3
Purpose of Action	LEVEL 2
Deficiency Photo 1	
Deficiency Photo 2	Stair AB/1
Violations	No photo recorded No violations recorded

**NYC Department of Education
Building Condition Assessment Survey 2023-2024**

Architectural Inspection



M015

Question	Response
INTERIOR	
STAIRS/RAMPS: INTERIOR	
Walls	Inspected
Condition	2- Between Good and Fair
Deficiency	MASONRY:CRACKS/SPALLING
Deficiency Location/Instance	Stair AB/4,5
Deficiency Quantity	20
Quantity Uom	S.F.
Potential Action	REPLACE
Urgency of Action	PRIORITY 3
Purpose of Action	LEVEL 2
Deficiency Photo 1	
Deficiency Photo 2	Stair AB/5
Violations	No photo recorded No violations recorded
Deficiency	CERAMIC TILE:BROKEN/ MISSING
Deficiency Location/Instance	Stair CD/3
Deficiency Quantity	15
Quantity Uom	S.F.
Potential Action	REPLACE
Urgency of Action	PRIORITY 3
Purpose of Action	LEVEL 2
Deficiency Photo 1	
Deficiency Photo 2	Stair CD/3
Violations	No photo recorded No violations recorded
Deficiency	PLASTER:CRACKS/SPALLING
Deficiency Location/Instance	Stair CD/5
Deficiency Quantity	25
Quantity Uom	S.F.
Potential Action	REPLACE
Urgency of Action	PRIORITY 3
Purpose of Action	LEVEL 2
Deficiency Photo 1	
Deficiency Photo 2	Stair CD/5

**NYC Department of Education
Building Condition Assessment Survey 2023-2024**

Architectural Inspection

M015

Question	Response
INTERIOR	
STAIRS/RAMPS: INTERIOR	
Walls	
Deficiency Photo 2	No photo recorded
Violations	No violations recorded
TOILET ROOMS - STAFF	
Ceiling	
Condition	2- Between Good and Fair
Deficiency	PLASTER:CRACKS/SPALLING
Deficiency Location/Instance	Inside Room 407
Deficiency Quantity	10
Quantity Uom	S.F.
Potential Action	REPLACE
Urgency of Action	PRIORITY 3
Purpose of Action	LEVEL 2
Deficiency Photo 1	
	Inside Room 407
Deficiency Photo 2	No photo recorded
Violations	No violations recorded
Door(s)	
Condition	5- Poor
Deficiency	WOOD:DETERIORATED DOOR
Deficiency Location/Instance	Gymnasium , Room 117, Inside Room 407, 507
Deficiency Quantity	4
Quantity Uom	EACH
Potential Action	MAINTENANCE
Urgency of Action	PRIORITY 3
Purpose of Action	LEVEL 2
Deficiency Photo 1	
	Room 117
Deficiency Photo 2	No photo recorded
Violations	No violations recorded
Floor Finish	
Condition	2- Between Good and Fair
Deficiency	No deficiencies recorded
Stalls	
Condition	5- Poor
Deficiency	RUST - MAJOR
Deficiency Location/Instance	Room 117, Inside Room 204
Deficiency Quantity	2
Quantity Uom	EACH

**NYC Department of Education
Building Condition Assessment Survey 2023-2024**

Architectural Inspection



M015

Question	Response
INTERIOR	
TOILET ROOMS - STAFF	
Stalls	
Potential Action	REPLACE
Urgency of Action	PRIORITY 3
Purpose of Action	LEVEL 2
Deficiency Photo 1	
Deficiency Photo 2	Room 117
Violations	No photo recorded No violations recorded
Walls	Inspected
Condition	2- Between Good and Fair
Deficiency	PLASTER:CRACKS/SPALLING
Deficiency Location/Instance	Inside Room 407, 507
Deficiency Quantity	15
Quantity Uom	S.F.
Potential Action	REPLACE
Urgency of Action	PRIORITY 3
Purpose of Action	LEVEL 2
Deficiency Photo 1	
Deficiency Photo 2	Inside Room 507
Violations	No photo recorded No violations recorded
Deficiency	CERAMIC TILE:BROKEN/ MISSING
Deficiency Location/Instance	Room 407, 414
Deficiency Quantity	10
Quantity Uom	S.F.
Potential Action	REPLACE
Urgency of Action	PRIORITY 3
Purpose of Action	LEVEL 2
Deficiency Photo 1	
Deficiency Photo 2	Inside Room 407
Violations	No photo recorded No violations recorded
TOILET ROOMS - STUDENTS	Inspected

**NYC Department of Education
Building Condition Assessment Survey 2023-2024**

Architectural Inspection

M015

Question	Response
INTERIOR	
TOILET ROOMS - STUDENTS	
Ceiling	Inspected
Condition	2- Between Good and Fair
Deficiency	PLASTER:CRACKS/SPALLING
Deficiency Location/Instance	4th Floor - Boys
Deficiency Quantity	10
Quantity Uom	S.F.
Potential Action	REPLACE
Urgency of Action	PRIORITY 3
Purpose of Action	LEVEL 2
Deficiency Photo 1	
Deficiency Photo 2	4th Floor - Boys No photo recorded
Violations	No violations recorded
Door(s)	Inspected
Condition	5- Poor
Deficiency	WOOD:DETERIORATED DOOR
Deficiency Location/Instance	Room 113A, 311
Deficiency Quantity	2
Quantity Uom	EACH
Potential Action	MAINTENANCE
Urgency of Action	PRIORITY 3
Purpose of Action	LEVEL 2
Deficiency Photo 1	
Deficiency Photo 2	Room 113A No photo recorded
Violations	No violations recorded
Floor Finish	Inspected
Condition	3- Fair
Deficiency	CERAMIC TILE:BROKEN/MISSING TILES
Deficiency Location/Instance	1st Floor - Boys, 1st Floor - Girls, 4th Floor - Boys, Room 511
Deficiency Quantity	75
Quantity Uom	S.F.
Potential Action	REPLACE
Urgency of Action	PRIORITY 3
Purpose of Action	LEVEL 2

**NYC Department of Education
Building Condition Assessment Survey 2023-2024**

Architectural Inspection



M015

Question	Response
INTERIOR	
TOILET ROOMS - STUDENTS	
Floor Finish	
Deficiency Photo 1	
Deficiency Photo 2	4th Floor - Boys
Violations	No photo recorded No violations recorded
Stalls	Inspected
Condition	2- Between Good and Fair
Deficiency	No deficiencies recorded
Walls	Inspected
Condition	2- Between Good and Fair
Deficiency	No deficiencies recorded
LIFE SAFETY	Inspected
F.D. HOLDING AREA	Does not exist
STEEL STAIRS	Does not exist
SITE	Inspected
CONTAINERIZATION	Does not exist
DRAINAGE SYSTEM FOR ASPHALT	Inspected
Catch Basins/Manhole - Surrounded by Asphalt	Inspected
Condition	2- Between Good and Fair
Deficiency	No deficiencies recorded
Culverts - Asphalt Covering	Does not exist
DRAINAGE SYSTEM FOR CONCRETE	Inspected
Catch Basins/Manhole - Surrounded by Concrete	Inspected
Condition	2- Between Good and Fair
Deficiency	No deficiencies recorded
Culverts - Concrete Covering	Does not exist
DRAINAGE SYSTEM FOR SOIL	Does not exist
DRINKING FOUNTAINS	Inspected
Condition	5- Poor
Deficiency	INOPERABLE
Deficiency Location/Instance	Schoolyard
Deficiency Quantity	1
Quantity Uom	EACH
Potential Action	MAINTENANCE
Urgency of Action	PRIORITY 3
Purpose of Action	LEVEL 2
Deficiency Photo 2	No photo recorded
Violations	No violations recorded
FENCES	Inspected
Condition	3- Fair
Deficiency	WROUGHT IRON:DAMAGED/DETERIORATED
Deficiency Location/Instance	Schoolyard
Deficiency Quantity	80
Quantity Uom	S.F.
Potential Action	REPLACE
Urgency of Action	PRIORITY 3

**NYC Department of Education
Building Condition Assessment Survey 2023-2024**

Architectural Inspection

M015

Question	Response
SITE	
FENCES	
Purpose of Action	LEVEL 2
Deficiency Photo 1	
Deficiency Photo 2	Schoolyard
Violations	No photo recorded No violations recorded
Deficiency	CHAIN LINK:DAMAGED POST/RAIL
Deficiency Location/Instance	Schoolyard
Deficiency Quantity	10
Quantity Uom	L.F.
Potential Action	REPLACE
Urgency of Action	PRIORITY 3
Purpose of Action	LEVEL 2
Deficiency Photo 1	
Deficiency Photo 2	Schoolyard
Violations	No photo recorded No violations recorded
Deficiency	CONCRETE CURB:DAMAGED/DETERIORATED
Deficiency Location/Instance	Schoolyard
Deficiency Quantity	30
Quantity Uom	S.F.
Potential Action	REPLACE
Urgency of Action	PRIORITY 3
Purpose of Action	LEVEL 2
Deficiency Photo 1	
Deficiency Photo 2	Schoolyard
Violations	No photo recorded No violations recorded
IRRIGATION SYSTEM	Does not exist
PAVING	Inspected
Student Non-Use	Inspected
Gravel Exists?	No
Asphalt	Inspected
Condition	2- Between Good and Fair

**NYC Department of Education
Building Condition Assessment Survey 2023-2024**

Architectural Inspection



M015

Question	Response
SITE	
PAVING	
Student Non-Use	
Asphalt	
Deficiency	No deficiencies recorded
Concrete	Inspected
Condition	2- Between Good and Fair
Deficiency	No deficiencies recorded
Pavers	Does not exist
Student Use	Inspected
Gravel Exists?	No
Asphalt	Inspected
Condition	2- Between Good and Fair
Deficiency	No deficiencies recorded
Concrete	Does not exist
Pavers	Inspected
Condition	2- Between Good and Fair
Deficiency	HEAVING
Deficiency Location/Instance	Schoolyard
Deficiency Quantity	20
Quantity Uom	S.F.
Potential Action	REPLACE
Urgency of Action	PRIORITY 3
Purpose of Action	LEVEL 2
Deficiency Photo 1	
Deficiency Photo 2	Schoolyard
Violations	No photo recorded No violations recorded
Site Sidewalks & Walkways	Inspected
Asphalt	Inspected
Condition	2- Between Good and Fair
Deficiency	CRACKS - MAJOR
Deficiency Location/Instance	Behind Building
Deficiency Quantity	20
Quantity Uom	S.F.
Potential Action	REPLACE
Urgency of Action	PRIORITY 3
Purpose of Action	LEVEL 2
Deficiency Photo 1	
Deficiency Photo 2	Behind Building No photo recorded

**NYC Department of Education
Building Condition Assessment Survey 2023-2024**

Architectural Inspection

M015

Question	Response
SITE	
PAVING	
Site Sidewalks & Walkways	
Asphalt	
Violations	No violations recorded
Concrete	Inspected
Condition	3- Fair
Deficiency	CRACKS - MAJOR
Deficiency Location/Instance	Main Entrance , Behind Building
Deficiency Quantity	75
Quantity Uom	S.F.
Potential Action	REPLACE
Urgency of Action	PRIORITY 3
Purpose of Action	LEVEL 2
Deficiency Photo 1	
Deficiency Photo 2	Main Entrance
Violations	No photo recorded No violations recorded
Deficiency	HEAVING
Deficiency Location/Instance	Main Entrance
Deficiency Quantity	50
Quantity Uom	S.F.
Potential Action	REPLACE
Urgency of Action	PRIORITY 3
Purpose of Action	LEVEL 2
Deficiency Photo 1	
Deficiency Photo 2	Main Entrance
Violations	No photo recorded No violations recorded
Pavers	Does not exist
DOT Sidewalk	Inspected
Asphalt	Does not exist
Concrete	Inspected
Condition	4- Between Fair and Poor
Deficiency	DAMAGED/DETERIORATED/MISSING SECTIONS
Deficiency Location/Instance	4th Street
Deficiency Quantity	500
Quantity Uom	S.F.
Potential Action	REPLACE
Urgency of Action	PRIORITY 3
Purpose of Action	LEVEL 2

**NYC Department of Education
Building Condition Assessment Survey 2023-2024**

Architectural Inspection

M015

Question	Response
SITE	
PAVING	
DOT Sidewalk	
Concrete	
Deficiency Photo 1	
Deficiency Photo 2	4th Street
Violations	No photo recorded No violations recorded
Pavers	Does not exist
PLAYGROUNDS	Inspected
Instance on Rear of School	Inspected
Instance on Schoolyard	Inspected
Benches	
Instance on Rear of School	Inspected
Instance Condition	2- Between Good and Fair
Deficiency	No deficiencies recorded
Instance on Schoolyard	Does not exist
Fence	
Instance on Rear of School	Inspected
Instance Condition	2- Between Good and Fair
Deficiency	No deficiencies recorded
Instance on Schoolyard	Does not exist
Pavement	
Instance on Rear of School	Inspected
Instance Condition	3- Fair
Deficiency	ASPHALT:CRACKS - MAJOR
Deficiency Location/Instance	Near Entrance
Deficiency Quantity	50
Quantity Uom	S.F.
Potential Action	REPLACE
Urgency of Action	PRIORITY 3
Purpose of Action	LEVEL 2
Deficiency Photo 1	
Deficiency Photo 2	Near Entrance
Violations	No photo recorded No violations recorded
Instance on Schoolyard	Does not exist
Play Equipment	
Instance on Rear of School	Inspected
Instance Condition	2- Between Good and Fair
Deficiency	No deficiencies recorded

**NYC Department of Education
Building Condition Assessment Survey 2023-2024**

Architectural Inspection

M015

Question	Response
SITE	
PLAYGROUNDS	
Play Equipment	
Instance on Schoolyard	Inspected
Instance Condition	1- Good
Deficiency	No deficiencies recorded
Safety Surfacing	
Instance on Rear of School	Inspected
Instance Condition	2- Between Good and Fair
Deficiency	No deficiencies recorded
Instance on Schoolyard	Inspected
Instance Condition	1- Good
Deficiency	No deficiencies recorded
Unpaved Area	
Instance on Rear of School	Does not exist
Instance on Schoolyard	Does not exist
PLAYING SURFACE	
Playing Field	
Instance on Schoolyard	Inspected
Instance Condition	2- Between Good and Fair
Deficiency	No deficiencies recorded
Running Track	
RETAINING WALLS	
Condition	3- Fair
Are there any Retaining Walls 6' OR higher facing public street/sidewalk?	No
Deficiency	BRICK:DETERIORATED COPING STONE
Deficiency Location/Instance	Schoolyard
Deficiency Quantity	80
Quantity Uom	S.F.
Potential Action	REPLACE
Urgency of Action	PRIORITY 3
Purpose of Action	LEVEL 2
Deficiency Photo 1	
Deficiency Photo 2	No photo recorded
Violations	No violations recorded
Deficiency	BRICK:CRACKS/SPALLING - MAJOR
Deficiency Location/Instance	Schoolyard
Deficiency Quantity	25
Quantity Uom	S.F.
Potential Action	REPLACE
Urgency of Action	PRIORITY 3
Purpose of Action	LEVEL 2

**NYC Department of Education
Building Condition Assessment Survey 2023-2024**

Architectural Inspection



M015

Question	Response
SITE	
RETAINING WALLS	
Deficiency Photo 1	
Deficiency Photo 2	Schoolyard
Violations	No photo recorded No violations recorded
SEATING	Inspected
Benches	Inspected
Concrete	Does not exist
Metal/Wood/Plastic	Inspected
Condition	2- Between Good and Fair
Deficiency	No deficiencies recorded
Bleachers	Does not exist
SITE WALLS (NOT RETAINING WALLS)	Inspected
Condition	2- Between Good and Fair
Deficiency	BRICK:CRACKS/SPALLING - MAJOR
Deficiency Location/Instance	Schoolyard
Deficiency Quantity	10
Quantity Uom	S.F.
Potential Action	REPLACE
Urgency of Action	PRIORITY 3
Purpose of Action	LEVEL 2
Deficiency Photo 1	
Deficiency Photo 2	Schoolyard
Violations	No photo recorded No violations recorded
Deficiency	BRICK:DETERIORATED COPING STONE
Deficiency Location/Instance	Schoolyard
Deficiency Quantity	10
Quantity Uom	S.F.
Potential Action	REPLACE
Urgency of Action	PRIORITY 3
Purpose of Action	LEVEL 2
Deficiency Photo 1	
	Schoolyard

**NYC Department of Education
Building Condition Assessment Survey 2023-2024**

Architectural Inspection

M015

Question	Response
SITE	
SITE WALLS (NOT RETAINING WALLS)	
Deficiency Photo 2	No photo recorded
Violations	No violations recorded
STAIRS/RAMPS: EXTERIOR	
Site Cheek/flank Walls	Inspected
Condition	2- Between Good and Fair
Deficiency	CAST IN PLACE CONCRETE:CRACKS/SPALLING - MAJOR
Deficiency Location/Instance	Schoolyard
Deficiency Quantity	10
Quantity Uom	S.F.
Potential Action	REPLACE
Urgency of Action	PRIORITY 3
Purpose of Action	LEVEL 2
Deficiency Photo 1	
	Schoolyard
Deficiency Photo 2	No photo recorded
Violations	No violations recorded
Railings	Inspected
Condition	2- Between Good and Fair
Deficiency	No deficiencies recorded
Stairs/ramps	
Condition	2- Between Good and Fair
Deficiency	CAST IN PLACE CONCRETE:CRACKS/SPALLING - MAJOR
Deficiency Location/Instance	Schoolyard
Deficiency Quantity	15
Quantity Uom	S.F.
Potential Action	REPLACE
Urgency of Action	PRIORITY 3
Purpose of Action	LEVEL 2
Deficiency Photo 1	
	Schoolyard
Deficiency Photo 2	No photo recorded
Violations	No violations recorded

NYC Department of Education
Building Condition Assessment Survey 2023-2024

Architectural Inspection

M015

Does the SCA expect asset to have artwork?

No