

NYC Department of Education
Building Condition Assessment Survey 2023 - 2024

Architectural Inspection

K934

Asset: FORT HAMILTON HS MODULAR UNIT - K, 8301 SHORE ROAD, New York, 11209

Inspection Id	Inspection Type	Time In	Last Edited
SA : K934	Architectural - Senior	2023-11-29 10:07 AM	2024-06-16 6:34 PM
AA : K934	Architectural - Associate	2023-11-29 9:23 AM	2023-12-11 3:10 PM

Asset Data

Question	Answer
Was the building fully accessible for inspection	Yes
Building Square Footage	22,000
Comments on the Area (for Athletic Field, Playing Surfaces, Leased Spaces)	None
Comments on the Stories (Floors) plus Basements	1 (No Basement)
Comments on the Number of Classrooms	19
Comments on the Year Built	1990
Student Population	494
Staff Population	19
Weather	Fair
Principal(s) Information	

Principal Name	Kaye Houlihan
Organization	Fort Hamilton High School - Brooklyn
Did you meet with this Principal?	No
Did this Principal provide feedback?	Yes
Summary of Principal's Feedback	Assistant Principal Jennifer Gagnon provided comments on behalf of the Principal as follows: The individual Classroom unit HVAC units need to be completely upgraded and replaced entirely.

Custodian

Anthony Altieri

Fireman

Lizardo Hernandez

Facade Photo



Corner of 83rd Street and Shore Road Drive
 - South View

**NYC Department of Education
Building Condition Assessment Survey 2023 - 2024**

Architectural Inspection

K934

Main Entrance Photo

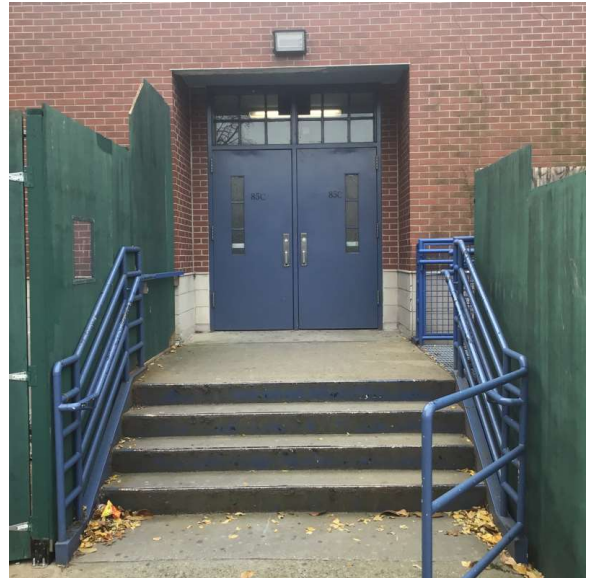

Facade A - Shore Road Drive

Roof Photo

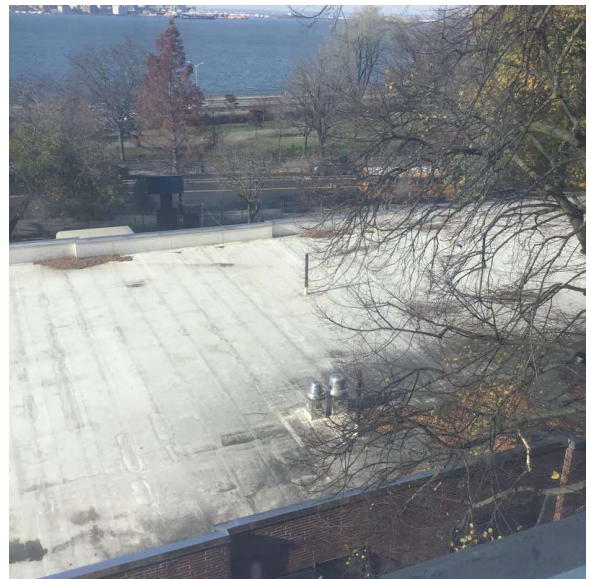

Roof 1 - West View

Have any Systems/Major Building Components been upgraded?

Yes

Systems: Window (Balances) - replacement

Year: 2021

Systems: Roofing, Parapets, Coping and Roof Drains - replacement

Year: 2020

Systems: Exterior Stairs - repairs

Year: 2019

Systems: Window - repairs

Year: 2017

Systems: Windows - replacement

Year: 1993

Have there been any Building Additions?

No

Tandem Schools?

No

Leased Space?

No

Priority Condition

Priority Condition Exist Last Year?	Priority Category	Condition Description	Component Affected	Location Description	Person(s) Notified	Person(s) Title	PhotoImage
No condition recorded							

NYC Department of Education
Building Condition Assessment Survey 2023 - 2024

Architectural Inspection

K934

Structural Engineer Required

Structural Condition Type	Condition Description	Component Affected	Location Description	Person(s) Notified	Person(s) Title	PhotoImage
No condition recorded						

Programmatic Accessibility

Programmatic Accessibility Status Question	Response
Is the primary or secondary entrance on an accessible route?	Yes
Is the building a multi-story building?	No
Do any of the following spaces exist? Classroom, Art Room, Auditorium, Cafeteria, Computer, Gymnasiums, Library, Multipurpose Room, Science Labs	Yes
For the spaces that do exist, are they ALL accessible?	Yes
Is there at least one Boys and Girls or Unisex toilet accessible in the building	Yes

Physical Breakdown Structure	Exists	Required	Complies	Deficiency	Assistive Listening System	Fire Alarm Strobe
------------------------------	--------	----------	----------	------------	----------------------------	-------------------

PROGRAMMATIC ACCESSIBILITY

Exterior Routes

Exterior Entrances & Exits			Yes			
Exterior H/C Lifts	No	No				
Exterior Ramps and Railings	Yes		Yes			

Interior Routes

Corridor and Lobby H/C Lifts	No	No				
Interior Corridor Doors and Hardware	Yes		Yes			
Interior Corridors and Lobbies			Yes			
Interior Elevators	No					
Interior Lobby Doors and Hardware			Yes			
Interior Ramps	Yes		Yes			

Rooms & Spaces

Art Rooms		No				
Auditorium		No				
Cafeteria		No				
Classrooms	1st Floor	Yes		Yes		
Computer Rooms		No				
Gymnasium		No				
Library		No				
Main Office		No				
Multi-purpose Room		No				
Nurse's Room		No				
Pool		No				
Science Lab		No				
Toilet Rooms (Boys)	1st Floor	Yes		Yes		
Toilet Rooms (Girls)	1st Floor	Yes		Yes		
Toilet Rooms (Staff)	1st Floor	Yes		Yes		

NYC Department of Education
 Building Condition Assessment Survey 2023 - 2024

Architectural Inspection

K934

Building Template

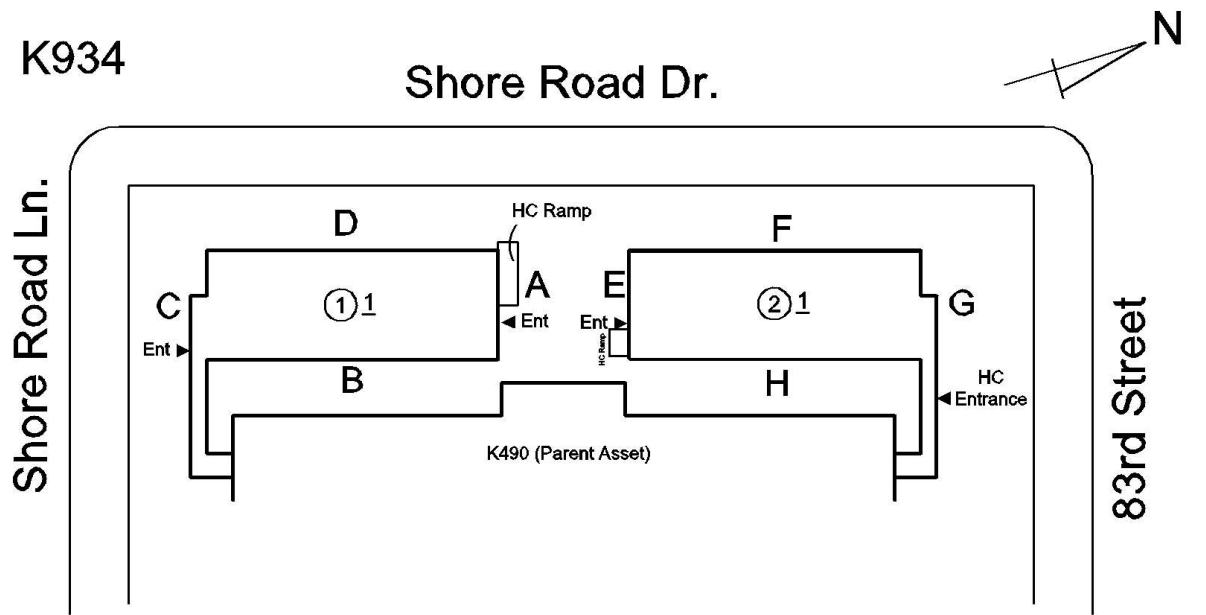

Inspection

Question	Response
Architectural	
EXTERIOR	Inspected
AREAWAY	Does not Exist
AWNINGS AND CANOPIES	Does not Exist
CHIMNEY	Does not Exist
COPING	Inspected
Condition	3 - Fair

Deficiency METAL: DETERIORATED

Roof Plan reference

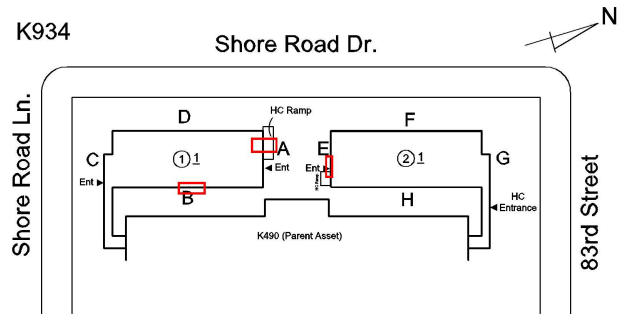

Deficiency Quantity

20

Quantity Uom

L.F.

Potential Action

REPLACE-IN-KIND

Urgency of Action

PRIORITY 4

Purpose of Action

LEVEL 2

**NYC Department of Education
Building Condition Assessment Survey 2023 - 2024**

Architectural Inspection

K934

Question	Response
----------	----------

EXTERIOR

COPING

Deficiency Photo1



Facade E

Violations

No violations recorded.

CORNICE

Inspected

Condition

3 - Fair

Deficiency

METAL: DETERIORATED

Roof Plan reference

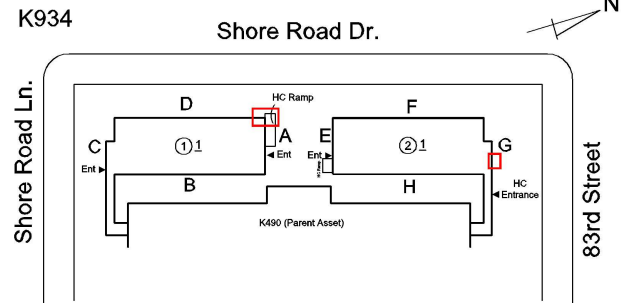

Deficiency Quantity

10

Quantity Uom

S.F.

Potential Action

REPLACE

Urgency of Action

PRIORITY 4

Purpose of Action

LEVEL 2

Deficiency Photo1



Facade D

Violations

No violations recorded.

DOORS

Inspected

DOORS AND FRAMES

Inspected

Condition

3 - Fair

Deficiency

METAL: DETERIORATED DOOR - MINOR DETERIORATION

**NYC Department of Education
Building Condition Assessment Survey 2023 - 2024**

Architectural Inspection

K934

Question	Response
----------	----------

EXTERIOR

DOORS

DOORS AND FRAMES

Roof Plan reference

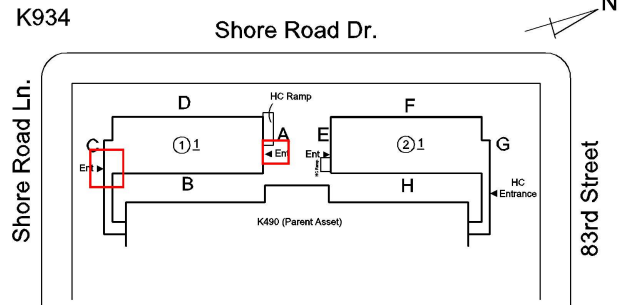

Deficiency Quantity
Quantity Uom
Potential Action
Urgency of Action
Purpose of Action
Deficiency Photo1

3
EACH
MAINTENANCE
PRIORITY 3
LEVEL 2



Facade C - Exit 85B

Violations

No violations recorded.

DOOR HARDWARE

Inspected

Condition

3 - Fair

Deficiency

No deficiencies recorded

LINTELS

Inspected

Condition

2 - Between Good and Fair

Deficiency

No deficiencies recorded

TRANSOM/SIDE LIGHT

Inspected

Condition

2 - Between Good and Fair

Deficiency

No deficiencies recorded

EXTERIOR WALLS

Inspected

Material Type(s)

Masonry

Replacement Quantity

9,000

Replacement Uom

S.F.

Instance on All Facades

Inspected

Instance Condition

3 - Fair

Instance Quantity

9,000

Instance Quantity Uom

S.F.

Deficiency

CONCRETE MASONRY UNIT: DETERIORATED MASONRY SILLS - MAJOR

**NYC Department of Education
Building Condition Assessment Survey 2023 - 2024**

Architectural Inspection

K934

Question

Response

EXTERIOR

EXTERIOR WALLS

Roof Plan reference

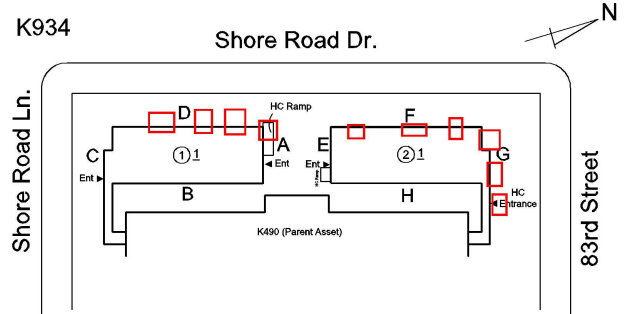

Elevation



Deficiency Quantity

50

Quantity Uom

L.F.

Potential Action

REMOVE AND REPLACE

Urgency of Action

PRIORITY 4

Purpose of Action

LEVEL 2

Deficiency Photo1



Facade F - Missing CMU Section

Violations

No violations recorded.

Deficiency

CONCRETE MASONRY UNIT: MINOR CRACKS AND SPALLING

Roof Plan reference

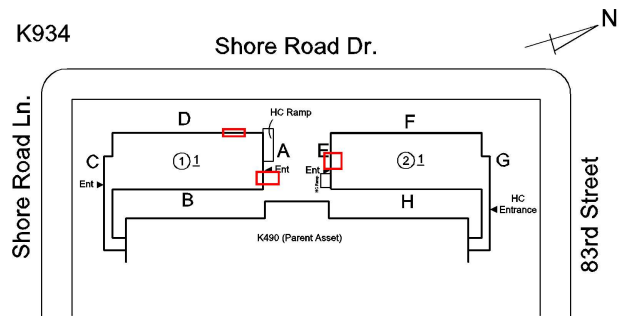

**NYC Department of Education
Building Condition Assessment Survey 2023 - 2024**

Architectural Inspection

K934

Question

Response

EXTERIOR

EXTERIOR WALLS

Elevation



Deficiency Quantity

30

Quantity Uom

S.F.

Potential Action

RESTITCH

Urgency of Action

PRIORITY 3

Purpose of Action

LEVEL 2

Deficiency Photo1



Facade D

No violations recorded.

Violations

Deficiency

BRICK: MINOR CRACKS AND SPALLING

Roof Plan reference

K934

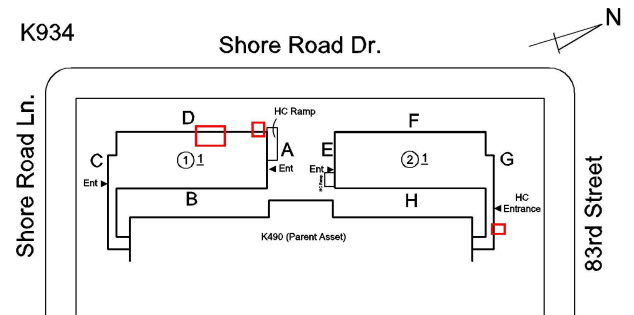

Elevation



Deficiency Quantity

30

Quantity Uom

S.F.

Potential Action

RESTITCH

Urgency of Action

PRIORITY 3

**NYC Department of Education
Building Condition Assessment Survey 2023 - 2024**

Architectural Inspection

K934

Question	Response
----------	----------

EXTERIOR

EXTERIOR WALLS

Purpose of Action
Deficiency Photo1

LEVEL 2



Facade D

No violations recorded.

Violations

EXTERIOR SOFFITS

Condition

Inspected

2 - Between Good and Fair

Deficiency

STUCCO/PLASTER: MINOR CRACKS/SPALLING

Roof Plan reference

K934

Shore Road Dr.

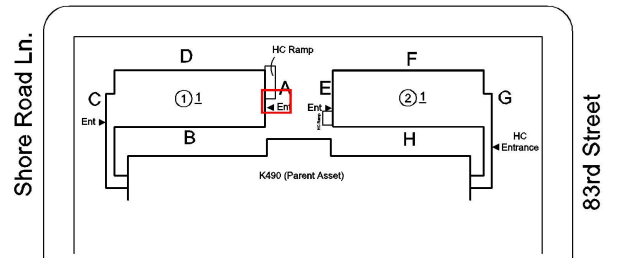

Elevation



Deficiency Quantity
Quantity Uom
Potential Action
Urgency of Action
Purpose of Action
Deficiency Photo1

10
S.F.
REPAIR
PRIORITY 3
LEVEL 2



Facade A - Exit 85A

**NYC Department of Education
Building Condition Assessment Survey 2023 - 2024**

Architectural Inspection



K934

Question	Response
EXTERIOR	
EXTERIOR SOFFITS	Inspected
Violations	No violations recorded.
LOADING DOCK	Does not Exist
LOUVER	Inspected
Condition	2 - Between Good and Fair
Deficiency	No deficiencies recorded
PARAPETS	Inspected
Material Type(s)	Masonry
Replacement Quantity	6,500
Replacement Uom	C.F.
Instance on All Facades	Inspected
Instance Condition	1 - Good
Instance Quantity	6,500
Instance Quantity Uom	C.F.
Deficiency	No deficiencies recorded
PLAZA DECK	Does not Exist
ROOF	Inspected
Roofing	Inspected
Replacement Quantity	24,000
Replacement Uom	S.F.
ROOF HATCH/SMOKE HATCH	Does not Exist
LEADERS, GUTTERS, DOWNSPOUTS, SCUPPERS	Inspected
Condition	2 - Between Good and Fair
Deficiency	No deficiencies recorded
ROOF BARRIER/FENCE	Does not Exist
ROOF CAGE	Does not Exist
ROOFING	Inspected
Instance on Single Ply, Fully Adhered Roof: All Roofs	Inspected
Instance Condition	1 - Good
Instance Photo	
	Roof 1
Instance Quantity	24,000
Instance Quantity Uom	S.F.
Does the roof have major mechanical equipment sitting on Dunnage Steel less than 18" above the Roofing?	No
Does this roof instance have a Sustainable Roof System?	Yes
Sustainable Roof Type	White Roof
Sustainable Roof Location (Roof Number)	Roofs 1, 2
Do solar panels exist on these roofs?	No
Is/Are the roof(s) suitable for Solar Panel installation?	Yes
Installation Year	2020
Source of Installation	Custodial Staff
Deficiency	No deficiencies recorded
ROOFING DRAINS	Inspected

**NYC Department of Education
Building Condition Assessment Survey 2023 - 2024**

Architectural Inspection

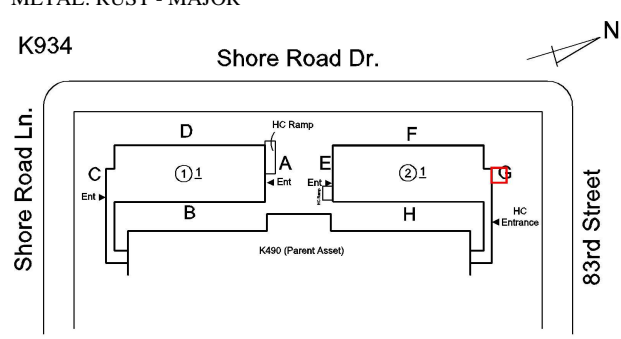
K934

Question	Response
EXTERIOR	
ROOF	Inspected
Roofing	Inspected
ROOFING DRAINS	
Condition	2 - Between Good and Fair
Deficiency	No deficiencies recorded
Specialties	Does not Exist
STAIRS/RAMPS: EXTERIOR	Inspected
BUILDING CHEEK/FLANK WALLS	Does not Exist
RAILINGS	Inspected
Condition	2 - Between Good and Fair
Deficiency	No deficiencies recorded
STAIRS/RAMPS	Inspected
Condition	5 - Poor
Deficiency	METAL: RUST - MAJOR
Roof Plan reference	<div style="display: flex; align-items: flex-start;"> <div style="margin-right: 20px;"> <p>Deficiency Quantity</p> <p>Quantity Uom</p> <p>Potential Action</p> <p>Urgency of Action</p> <p>Purpose of Action</p> <p>Deficiency Photo1</p> </div> <div> <p>K934</p> <p align="center">Shore Road Dr.</p>  <p align="right">83rd Street</p> </div> </div>
	60
	S.F.
	REPLACE
	PRIORITY 4
	LEVEL 2
	
	Facade G
	No violations recorded.
VIOLATIONS	
WINDOWS	Inspected
Replacement Quantity	2,400
Replacement Uom	S.F.
EXTERIOR GUARDS	Inspected
Condition	2 - Between Good and Fair
Deficiency	No deficiencies recorded
LINTELS	Inspected
Condition	2 - Between Good and Fair
Deficiency	No deficiencies recorded
WINDOWS	Inspected

NYC Department of Education
Building Condition Assessment Survey 2023 - 2024

Architectural Inspection

K934

Question	Response
EXTERIOR	
WINDOWS	
WINDOWS	
Material Type(s)	Aluminum
Instance on Aluminum - Double Hung: All Facades	Inspected
Instance Condition	3 - Fair
Instance Quantity	2,400
Instance Quantity Uom	S.F.
Are these windows insulated	Yes
Installation Year	1993
Source of Installation	Custodial Staff
Deficiency	No deficiencies recorded
INTERIOR	Inspected
POOLS	Does not Exist
STRUCTURAL	Inspected
COLUMNS/BEAMS/BEARING WALLS	Inspected
Condition	2 - Between Good and Fair
Deficiency	No deficiencies recorded
FLOOR STRUCTURE	Inspected
Condition	2 - Between Good and Fair
Deficiency	No deficiencies recorded
FOUNDATION WALLS	Inspected
Material Type(s)	Concrete
Condition	2 - Between Good and Fair
Deficiency	No deficiencies recorded
ROOF STRUCTURE	Inspected
Condition	2 - Between Good and Fair
Deficiency	No deficiencies recorded
VAULTS-BUNKERS	Does not Exist
AUDITORIUM	Does not Exist
CAFETERIA	Does not Exist
CLASSROOMS/CORRIDORS/ADMIN SPACES	Inspected
Ceiling	Inspected
Condition	2 - Between Good and Fair
Deficiency	GYPSUM BOARD: DAMAGED/DETERIORATED
Deficiency Location/Instance	Corridor near Exit 85B
Deficiency Quantity	10
Quantity Uom	S.F.
Potential Action	REPLACE
Urgency of Action	PRIORITY 3
Purpose of Action	LEVEL 2
Deficiency Photo1	

NYC Department of Education
Building Condition Assessment Survey 2023 - 2024

Architectural Inspection

K934

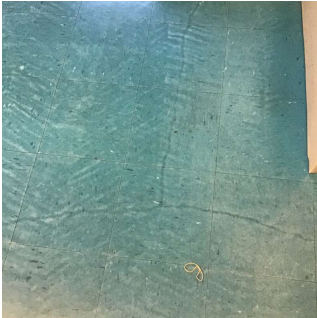
Question	Response
INTERIOR	
CLASSROOMS/CORRIDORS/ADMIN SPACES	
Ceiling	
Violations	Corridor near Exit 85B No violations recorded.
Deficiency	ACOUSTIC TILES: DAMAGED/MISSING
Deficiency Location/Instance	Near Exits 83A, 85A, Corridor near Room 860
Deficiency Quantity	30
Quantity Uom	S.F.
Potential Action	REPLACE
Urgency of Action	PRIORITY 3
Purpose of Action	LEVEL 2
Deficiency Photo1	
Violations	Near Exit 83A No violations recorded.
Door(s)	Inspected
Condition	2 - Between Good and Fair
Deficiency	No deficiencies recorded
Floor Finish	Inspected
Condition	2 - Between Good and Fair
Deficiency	VINYL TILES: DETERIORATED SUBSTRATE
Deficiency Location/Instance	Rooms 863, 839, Corridor near Rooms 835, 839, and others
Deficiency Quantity	100
Quantity Uom	S.F.
Potential Action	REPLACE
Urgency of Action	PRIORITY 3
Purpose of Action	LEVEL 2
Deficiency Photo1	
Violations	Room 839 No violations recorded.
Deficiency	VINYL TILES: BROKEN/DETERIORATED/MISSING TILES
Deficiency Location/Instance	Corridor near Rooms 854, 855, Corridor near Exit 83B
Deficiency Quantity	50
Quantity Uom	S.F.

**NYC Department of Education
Building Condition Assessment Survey 2023 - 2024**

Architectural Inspection

K934

Question	Response
INTERIOR	
CLASSROOMS/CORRIDORS/ADMIN SPACES	
Floor Finish	
Potential Action	REPLACE
Urgency of Action	PRIORITY 3
Purpose of Action	LEVEL 2
Deficiency Photo1	
	Corridor near Exit 83B
Violations	No violations recorded.
Walls	
Condition	Inspected 2 - Between Good and Fair
Deficiency	GYPSUM BOARD: DETERIORATED
Deficiency Location/Instance	Corridor near Rooms 834, 839, 841, Exit 83C, Exit 85C, and others
Deficiency Quantity	250
Quantity Uom	S.F.
Potential Action	REPLACE
Urgency of Action	PRIORITY 3
Purpose of Action	LEVEL 2
Deficiency Photo1	
	Corridor near Room 839
Violations	No violations recorded.
Specialties	
Classroom Locker(s)	
Condition	Inspected 2 - Between Good and Fair
Deficiency	No deficiencies recorded
Fixed Seating	
Does not Exist	
GYMNASIUM	
Does not Exist	
INTERIOR DOOR HARDWARE	
Condition	Inspected 3 - Fair
Deficiency	No deficiencies recorded
INTERIOR GUARDS	
Does not Exist	
KITCHEN	
Does not Exist	
LIBRARY	
Does not Exist	

NYC Department of Education
Building Condition Assessment Survey 2023 - 2024

Architectural Inspection

K934

Question	Response
INTERIOR	
LOCKER ROOM	Does not Exist
MULTI-PURPOSE ROOM	Does not Exist
SCIENCE DEMO ROOM	Does not Exist
SCIENCE LAB	Does not Exist
SCIENCE PREP ROOM	Does not Exist
SHOWER ROOM	Does not Exist
STAIRS/RAMPS: INTERIOR	Inspected
Do Letter Stair Signs Exist?	No
Ceiling	Not Required
Door(s)	Does not Exist
Partition	Does not Exist
Railings	Inspected
Condition	2 - Between Good and Fair
Deficiency	No deficiencies recorded
Stairs and Landings	Inspected
Condition	5 - Poor
Deficiency	VINYL TILES: DETERIORATED SUBSTRATE
Deficiency Location/Instance	Corridor Ramp Near Exit 83D, Corridor Ramp Near Exit 85B
Deficiency Quantity	20
Quantity Uom	S.F.
Potential Action	REPLACE
Urgency of Action	PRIORITY 3
Purpose of Action	LEVEL 2
Deficiency Photo1	
Corridor Ramp Near Exit 83D	
Violations	No violations recorded.
Deficiency	STONE: BROKEN/MISSING
Deficiency Location/Instance	Near Exits 83A, 85A
Deficiency Quantity	50
Quantity Uom	S.F.
Potential Action	REPLACE
Urgency of Action	PRIORITY 3
Purpose of Action	LEVEL 2

**NYC Department of Education
Building Condition Assessment Survey 2023 - 2024**

Architectural Inspection

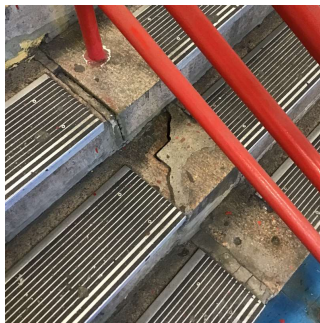

K934

Question	Response
INTERIOR	
STAIRS/RAMPS: INTERIOR	
Stairs and Landings	Inspected
Deficiency Photo1	
	Near Exit 83A
Violations	No violations recorded.
Walls	Not Required
TOILET ROOMS - STAFF	
	Inspected
Ceiling	Inspected
Condition	2 - Between Good and Fair
Deficiency	No deficiencies recorded
Door(s)	Inspected
Condition	2 - Between Good and Fair
Deficiency	No deficiencies recorded
Floor Finish	Inspected
Condition	2 - Between Good and Fair
Deficiency	No deficiencies recorded
Stalls	Does not Exist
Walls	Inspected
Condition	2 - Between Good and Fair
Deficiency	No deficiencies recorded
TOILET ROOMS - STUDENTS	
	Inspected
Ceiling	Inspected
Condition	2 - Between Good and Fair
Deficiency	No deficiencies recorded
Door(s)	Inspected
Condition	2 - Between Good and Fair
Deficiency	No deficiencies recorded
Floor Finish	Inspected
Condition	2 - Between Good and Fair
Deficiency	CERAMIC TILE: BROKEN/MISSING TILES
Deficiency Location/Instance	Room 854
Deficiency Quantity	10
Quantity Uom	S.F.
Potential Action	REPLACE
Urgency of Action	PRIORITY 3
Purpose of Action	LEVEL 2

**NYC Department of Education
Building Condition Assessment Survey 2023 - 2024**

Architectural Inspection

K934

Question	Response
INTERIOR	
TOILET ROOMS - STUDENTS	
Floor Finish	
Deficiency Photo1	
Violations	Room 854 No violations recorded.
Stalls	Inspected
Condition	2 - Between Good and Fair
Deficiency	No deficiencies recorded
Walls	Inspected
Condition	2 - Between Good and Fair
Deficiency	No deficiencies recorded
LIFE SAFETY	Inspected
F.D. HOLDING AREA	Does not Exist
STEEL STAIRS	Does not Exist
SITE	Not Required
ARTWORK	Inspected
Instance	Interior - Library in K490 - 31283
Instance Photo	
Instance ID	Library 31283
Artwork exist at stated location?	Yes