

NYC Department of Education
Building Condition Assessment Survey 2023 - 2024

Architectural Inspection

K876

Asset: P.S. 274 MINISCHOOL - BROOKLYN, 800 BUSHWICK AVENUE, New York, 11221

Inspection Id	Inspection Type	Time In	Last Edited
SA : K876	Architectural - Senior	2023-11-16 8:02 AM	2023-11-29 4:18 PM
AA : K876	Architectural - Associate	2023-11-16 9:09 AM	2023-11-30 11:41 AM

Asset Data

Question	Answer
Was the building fully accessible for inspection	Yes
Building Square Footage	12,000
Comments on the Area (for Athletic Field, Playing Surfaces, Leased Spaces)	None
Comments on the Stories (Floors) plus Basements	1 (No Basement)
Comments on the Number of Classrooms	7
Comments on the Year Built	1972
Student Population	131
Staff Population	9
Weather	Fair
Principal(s) Information	
Principal Name	Maritza Ollivierra Jone
Organization	P.S. 274 Minischool - Brooklyn
Did you meet with this Principal?	Yes
Did this Principal provide feedback?	Yes
Summary of Principal's Feedback	The Principals comment is as follows: The exterior wall in Classroom 10/11 has a leak. (no deficiencies observed).
Custodian	Wolfgang Hellmann
Fireman	Edgar Hiller
Facade Photo	



Kosciuszko Street - West View

**NYC Department of Education
Building Condition Assessment Survey 2023 - 2024**

Architectural Inspection

K876

Main Entrance Photo



Facade A - Main Entrance

Roof Photo

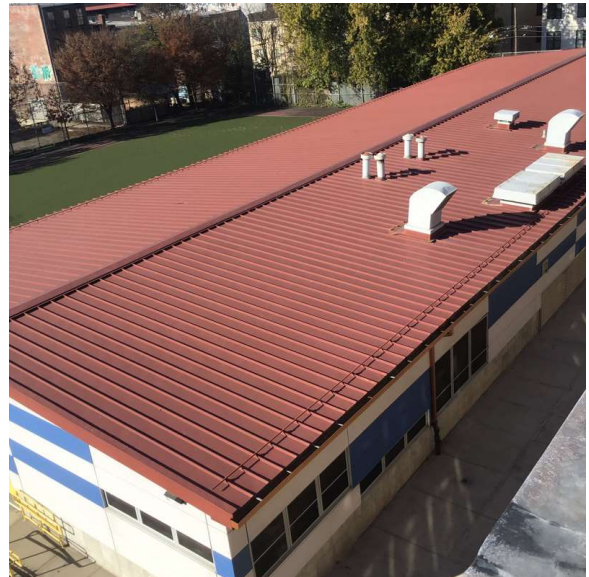

Roof 1 - West View

Have any Systems/Major Building Components been upgraded?

Yes

Systems: Exterior Walls - repairs

Year: 2023

Systems: Transom/Side Lights, Windows - repairs

Year: 2019

Systems: Exterior Walls, Windows, Exterior Guards, Exterior Doors and Frames, Exterior Stairs/Ramps - replacement; Foundation Walls - repairs

Year: 2010

Systems: Roofing, Leaders/Gutters/Downspout - replacement

Year: 2006

Have there been any Building Additions?

No

Tandem Schools?

No

Leased Space?

No

Priority Condition

Priority Condition Exist Last Year?	Priority Category	Condition Description	Component Affected	Location Description	Person(s) Notified	Person(s) Title	PhotoImage
-------------------------------------	-------------------	-----------------------	--------------------	----------------------	--------------------	-----------------	------------

No condition recorded

NYC Department of Education
Building Condition Assessment Survey 2023 - 2024

Architectural Inspection

K876

Structural Engineer Required

Structural Condition Type	Condition Description	Component Affected	Location Description	Person(s) Notified	Person(s) Title	PhotoImage
No condition recorded						

Programmatic Accessibility

Programmatic Accessibility Status Question	Response
Is the primary or secondary entrance on an accessible route?	Yes
Is the building a multi-story building?	No
Do any of the following spaces exist? Classroom, Art Room, Auditorium, Cafeteria, Computer, Gymnasiums, Library, Multipurpose Room, Science Labs	Yes
For the spaces that do exist, are they ALL accessible?	Yes
Is there at least one Boys and Girls or Unisex toilet accessible in the building	No

Physical Breakdown Structure	Exists	Required	Complies	Deficiency	Assistive Listening System	Fire Alarm Strobe
------------------------------	--------	----------	----------	------------	----------------------------	-------------------

PROGRAMMATIC ACCESSIBILITY

Exterior Routes

Exterior Entrances & Exits			Yes			
Exterior H/C Lifts	No	No				
Exterior Ramps and Railings	Yes		Yes			

Interior Routes

Corridor and Lobby H/C Lifts	No	No				
Interior Corridor Doors and Hardware	No	No				
Interior Corridors and Lobbies			Yes			
Interior Elevators	No					
Interior Lobby Doors and Hardware			Yes			
Interior Ramps	No					

Rooms & Spaces

Art Rooms		No				
Auditorium		No				
Cafeteria		No				
Classrooms	1st Floor	Yes		Yes		
Computer Rooms		No				
Gymnasium		No				
Library		No				
Main Office		No				
Multi-purpose Room		No				
Nurse's Room		No				
Pool		No				
Science Lab		No				
Toilet Rooms (Boys)	1st Floor	Yes		No	Accessory Arrangement Turning Radius Water Closet Arrangement	
Toilet Rooms (Girls)	1st Floor	Yes		No	Accessory Arrangement Turning Radius Water Closet Arrangement	

NYC Department of Education
Building Condition Assessment Survey 2023 - 2024

Architectural Inspection

K876

Physical Breakdown Structure	Exists	Required	Complies	Deficiency	Assistive Listening System	Fire Alarm Strobe
Rooms & Spaces						
Toilet Rooms (Staff) 1st Floor	Yes		No	Accessory Arrangement Turning Radius Water Closet Arrangement		

Building Template

K876

Kosciuszko Street

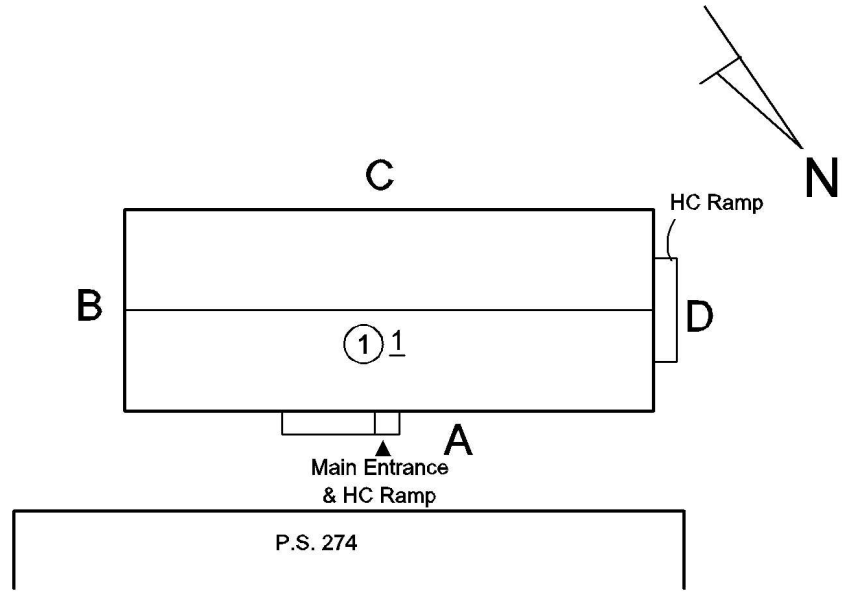

Inspection

Question	Response
Architectural	
EXTERIOR	Inspected
AREAWAY	Does not Exist
AWNINGS AND CANOPIES	Does not Exist
CHIMNEY	Does not Exist
COPING	Does not Exist
CORNICE	Does not Exist
DOORS	Inspected
DOORS AND FRAMES	Inspected
Condition	2 - Between Good and Fair
Deficiency	No deficiencies recorded
DOOR HARDWARE	Inspected
Condition	2 - Between Good and Fair
Deficiency	No deficiencies recorded
LINTELS	Does not Exist
TRANSOM/SIDE LIGHT	Inspected
Condition	2 - Between Good and Fair
Deficiency	No deficiencies recorded
EXTERIOR WALLS	Inspected
Material Type(s)	Steel
Replacement Quantity	5,600
Replacement Uom	S.F.

NYC Department of Education
Building Condition Assessment Survey 2023 - 2024

Architectural Inspection

K876

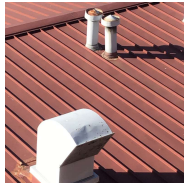
Question	Response
EXTERIOR	
EXTERIOR WALLS	
Instance on All Facades	Inspected
Instance Condition	2 - Between Good and Fair
Instance Quantity	5,600
Instance Quantity Uom	S.F.
Deficiency	No deficiencies recorded
EXTERIOR SOFFITS	Inspected
Condition	2 - Between Good and Fair
Deficiency	No deficiencies recorded
LOADING DOCK	Does not Exist
LOUVER	Inspected
Condition	2 - Between Good and Fair
Deficiency	No deficiencies recorded
PARAPETS	Does not Exist
PLAZA DECK	Does not Exist
ROOF	Inspected
Roofing	Inspected
Replacement Quantity	12,000
Replacement Uom	S.F.
ROOF HATCH/SMOKE HATCH	Does not Exist
LEADERS, GUTTERS, DOWNSPOUTS, SCUPPERS	Inspected
Condition	2 - Between Good and Fair
Deficiency	No deficiencies recorded
ROOF BARRIER/FENCE	Does not Exist
ROOF CAGE	Does not Exist
ROOFING	Inspected
Instance on Metal: Roof 1	Inspected
Instance Condition	1 - Good
Instance Photo	
	Roof
Instance Quantity	12,000
Instance Quantity Uom	S.F.
Does the roof have major mechanical equipment sitting on Dunnage Steel less than 18" above the Roofing?	No
Does this roof instance have a Sustainable Roof System?	No
Do solar panels exist on these roofs?	No
Is/Are the roof(s) suitable for Solar Panel installation?	Yes
Installation Year	2006
Source of Installation	Custodial Staff
Deficiency	No deficiencies recorded
ROOFING DRAINS	Does not Exist
Specialties	Does not Exist
STAIRS/RAMPS: EXTERIOR	Inspected
BUILDING CHEEK/FLANK WALLS	Inspected

NYC Department of Education
Building Condition Assessment Survey 2023 - 2024

Architectural Inspection



K876

Question	Response
EXTERIOR	
STAIRS/RAMPS: EXTERIOR	
BUILDING CHEEK/FLANK WALLS	Inspected
Condition	2 - Between Good and Fair
Deficiency	No deficiencies recorded
RAILINGS	Inspected
Condition	2 - Between Good and Fair
Deficiency	No deficiencies recorded
STAIRS/RAMPS	Inspected
Condition	2 - Between Good and Fair
Deficiency	No deficiencies recorded
WINDOWS	Inspected
Replacement Quantity	380
Replacement Uom	S.F.
EXTERIOR GUARDS	Inspected
Condition	2 - Between Good and Fair
Deficiency	No deficiencies recorded
LINTELS	Does not Exist
WINDOWS	Inspected
Material Type(s)	Aluminum
Instance on Aluminum - Other: All Facades	Inspected
Instance Condition	2 - Between Good and Fair
Instance Quantity	380
Instance Quantity Uom	S.F.
Are these windows insulated	Yes
Installation Year	2010
Source of Installation	Custodial Staff
Deficiency	No deficiencies recorded
INTERIOR	Inspected
POOLS	Does not Exist
STRUCTURAL	Inspected
COLUMNS/BEAMS/BEARING WALLS	Inspected
Condition	2 - Between Good and Fair
Deficiency	No deficiencies recorded
FLOOR STRUCTURE	Inspected
Condition	2 - Between Good and Fair
Deficiency	No deficiencies recorded
FOUNDATION WALLS	Inspected
Material Type(s)	Concrete
Condition	2 - Between Good and Fair
Deficiency	No deficiencies recorded
ROOF STRUCTURE	Inspected
Condition	2 - Between Good and Fair
Deficiency	No deficiencies recorded
VAULTS-BUNKERS	Does not Exist
AUDITORIUM	Does not Exist
CAFETERIA	Does not Exist
CLASSROOMS/CORRIDORS/ADMIN SPACES	Inspected
Ceiling	Inspected

**NYC Department of Education
Building Condition Assessment Survey 2023 - 2024**

Architectural Inspection

K876

Question	Response
INTERIOR	
CLASSROOMS/CORRIDORS/ADMIN SPACES	
Ceiling	
Condition	2 - Between Good and Fair
Deficiency	ACOUSTIC TILES: DAMAGED/MISSING
Deficiency Location/Instance	Rooms 1-2, M12, Corridor near Rooms 1-2, 4, Exit Vestibule 3, and others
Deficiency Quantity	80
Quantity Uom	S.F.
Potential Action	REPLACE
Urgency of Action	PRIORITY 3
Purpose of Action	LEVEL 2
Deficiency Photo1	
Violations	Room M12 No violations recorded.
Door(s)	
Condition	Inspected
Condition	5 - Poor
Deficiency	WOOD: DETERIORATED DOOR
Deficiency Location/Instance	Rooms 1-2, 3, 4, 9, 10
Deficiency Quantity	5
Quantity Uom	EACH
Potential Action	MAINTENANCE
Urgency of Action	PRIORITY 3
Purpose of Action	LEVEL 2
Deficiency Photo1	
Violations	Room 1-2 No violations recorded.
Floor Finish	
Condition	Inspected
Condition	2 - Between Good and Fair
Deficiency	VINYL TILES: BROKEN/DETERIORATED/MISSING TILES
Deficiency Location/Instance	Corridor near Room 3
Deficiency Quantity	20
Quantity Uom	S.F.
Potential Action	REPLACE

NYC Department of Education
Building Condition Assessment Survey 2023 - 2024

Architectural Inspection



K876

Question	Response
INTERIOR	
CLASSROOMS/CORRIDORS/ADMIN SPACES	
Floor Finish	
Urgency of Action	PRIORITY 3
Purpose of Action	LEVEL 2
Deficiency Photo1	
	Room 9
Violations	No violations recorded.
Walls	
Condition	Inspected
Deficiency	2 - Between Good and Fair
Deficiency Location/Instance	MASONRY: CRACKS/SPALLING
Deficiency Quantity	Corridor near Room 11
Quantity Uom	10
Potential Action	S.F.
Urgency of Action	REPLACE
Purpose of Action	PRIORITY 3
Deficiency Photo1	LEVEL 2
	
	Corridor near Room 11
Violations	No violations recorded.
Specialties	Does not Exist
GYMNASIUM	Does not Exist
INTERIOR DOOR HARDWARE	Inspected
Condition	3 - Fair
Deficiency	No deficiencies recorded
INTERIOR GUARDS	Does not Exist
KITCHEN	Does not Exist
LIBRARY	Does not Exist
LOCKER ROOM	Does not Exist
MULTI-PURPOSE ROOM	Does not Exist
SCIENCE DEMO ROOM	Does not Exist
SCIENCE LAB	Does not Exist
SCIENCE PREP ROOM	Does not Exist

**NYC Department of Education
Building Condition Assessment Survey 2023 - 2024**

Architectural Inspection

K876

Question	Response
INTERIOR	
SHOWER ROOM	Does not Exist
STAIRS/RAMPS: INTERIOR	Does not Exist
TOILET ROOMS - STAFF	Inspected
Ceiling	Inspected
Condition	4 - Between Fair and Poor
Deficiency	ACOUSTIC TILES: DAMAGED/MISSING
Deficiency Location/Instance	Men
Deficiency Quantity	10
Quantity Uom	S.F.
Potential Action	REPLACE
Urgency of Action	PRIORITY 3
Purpose of Action	LEVEL 2
Deficiency Photo1	
Violations	Men No violations recorded.
Door(s)	Inspected
Condition	5 - Poor
Deficiency	METAL: DETERIORATED DOOR AND FRAME
Deficiency Location/Instance	Women
Deficiency Quantity	1
Quantity Uom	EACH
Potential Action	MAINTENANCE
Urgency of Action	PRIORITY 3
Purpose of Action	LEVEL 2
Deficiency Photo1	
Violations	Women No violations recorded.
Floor Finish	Inspected
Condition	2 - Between Good and Fair
Deficiency	No deficiencies recorded
Stalls	Inspected
Condition	5 - Poor
Deficiency	RUST - MAJOR

**NYC Department of Education
Building Condition Assessment Survey 2023 - 2024**

Architectural Inspection

K876

Question	Response
INTERIOR	
TOILET ROOMS - STAFF	
Stalls	
Deficiency Location/Instance	Women, Men
Deficiency Quantity	2
Quantity Uom	EACH
Potential Action	REPLACE
Urgency of Action	PRIORITY 3
Purpose of Action	LEVEL 2
Deficiency Photo1	
Violations	Women No violations recorded.
Walls	Inspected
Condition	2 - Between Good and Fair
Deficiency	No deficiencies recorded
TOILET ROOMS - STUDENTS	
Ceiling	Inspected
Condition	2 - Between Good and Fair
Deficiency	No deficiencies recorded
Door(s)	Inspected
Condition	5 - Poor
Deficiency	METAL: DETERIORATED DOOR AND FRAME
Deficiency Location/Instance	Boys, Girls
Deficiency Quantity	2
Quantity Uom	EACH
Potential Action	MAINTENANCE
Urgency of Action	PRIORITY 3
Purpose of Action	LEVEL 2
Deficiency Photo1	
Violations	Boys No violations recorded.
Floor Finish	Inspected
Condition	2 - Between Good and Fair
Deficiency	No deficiencies recorded

**NYC Department of Education
Building Condition Assessment Survey 2023 - 2024**

Architectural Inspection

K876

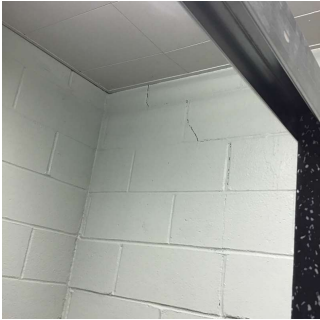
Question	Response
INTERIOR	
TOILET ROOMS - STUDENTS	
Stalls	Inspected
Condition	2 - Between Good and Fair
Deficiency	No deficiencies recorded
Walls	Inspected
Condition	2 - Between Good and Fair
Deficiency	MASONRY: CRACKS/SPALLING
Deficiency Location/Instance	Boys
Deficiency Quantity	10
Quantity Uom	S.F.
Potential Action	REPLACE
Urgency of Action	PRIORITY 3
Purpose of Action	LEVEL 2
Deficiency Photo1	
Violations	Boys No violations recorded.
LIFE SAFETY	Inspected
F.D. HOLDING AREA	Does not Exist
STEEL STAIRS	Does not Exist
SITE	Not Required
ARTWORK	Does not Exist