

NYC Department of Education
Building Condition Assessment Survey 2023 - 2024

Architectural Inspection

K415

Asset: SAMUEL J. TILDEN HS - K, 5800 TILDEN AVENUE, New York, 11203

Inspection Id	Inspection Type	Time In	Last Edited
SA : K415	Architectural - Senior	2024-02-08 8:24 AM	2024-02-26 9:18 AM
AA : K415	Architectural - Associate	2024-02-08 9:08 AM	2024-02-27 5:29 PM

Asset Data

Question	Answer
Was the building fully accessible for inspection	No
Inspection Access Comment	Sub-basement - Pool Mechanical Equipment Room; Basement - Boys and Girls Locker Rooms and Shower Rooms, Swimming Pool, Pool Ceiling, Pool Deck/Floor, Pool Lining, Pool Structure, Pool Seating, Pool Walls; Computer Lab Room 321 (Construction)
Building Square Footage	247,000
Comments on the Area (for Athletic Field, Playing Surfaces, Leased Spaces)	None
Comments on the Stories (Floors) plus Basements	3+B+SB
Comments on the Number of Classrooms	90
Comments on the Year Built	1929
Student Population	740
Staff Population	170
Weather	Fair
Principal(s) Information	
Principal Name	Yvrose Pierre
Organization	Averyon Business Academy
Did you meet with this Principal?	No
Did this Principal provide feedback?	No
Principal Name	Victor Frias
Organization	It Takes a Village Academy - Brooklyn
Did you meet with this Principal?	Yes
Did this Principal provide feedback?	Yes
Summary of Principal's Feedback	The Principal had no comments regarding the physical condition of the building at this time.
Principal Name	Jessica Jean-Marie
Organization	Kurt Hahn Expeditionary Learning School - Brooklyn
Did you meet with this Principal?	No
Did this Principal provide feedback?	No
Principal Name	Alexis Sanatha
Organization	Cultural Academy for the Arts and Sciences - Brooklyn
Did you meet with this Principal?	No
Did this Principal provide feedback?	No
Custodian	Was not present
Fireman	Saleh Al-Awgari

NYC Department of Education
Building Condition Assessment Survey 2023 - 2024

Architectural Inspection

K415

Facade Photo



Corner of East 59th Street & East 57th Street - Southwest View

Main Entrance Photo



Facade A - Tilden Avenue

Roof Photo

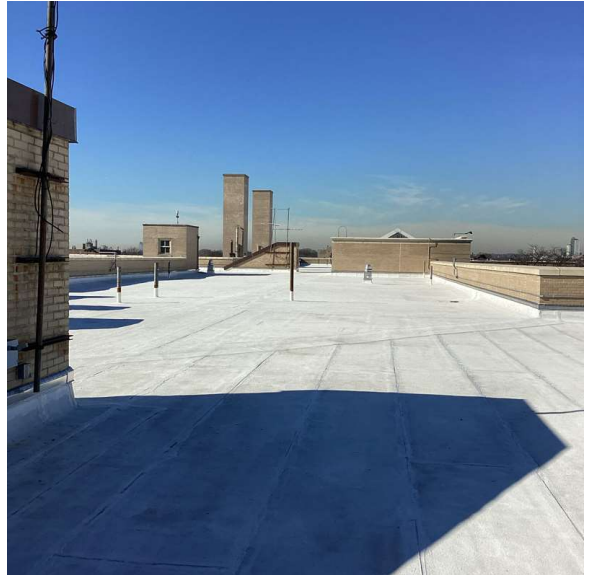

Roof 1 - West View

NYC Department of Education
Building Condition Assessment Survey 2023 - 2024

Architectural Inspection

K415

Have any Systems/Major Building Components been upgraded?

Yes
 Systems: Foundation Walls
 Year: Under Construction
 Systems: Coping, Cornice, Parapets, Roof Drains, Roofing, Roof Barrier - replacement; Exterior Walls, Bulkhead, Building Cheek/Flank Walls, Stairs/Ramp - repairs
 Year: 2023
 Systems: Chimney - repairs
 Year: 2022
 Systems: Exterior Walls - repairs
 Year: 2015
 Systems: Doors, Leaders and Gutters, Windows, Exterior Guards - replacement; Exterior Walls, Skylight - repairs
 Year: 2002

No
 No
 No

Have there been any Building Additions?
 Tandem Schools?
 Leased Space?

Priority Condition

Priority Condition Exist Last Year?	Priority Category	Condition Description	Component Affected	Location Description	Person(s) Notified	Person(s) Title	PhotoImage
No	Protruding Elements	Severely damaged fence is a potential safety hazard.	SITE FENCES	Near Exit 9	Saleh Al-Awgari	Fireman	
No	Tripping Hazard	Severely damaged concrete DOT sidewalk is a potential tripping hazard.	SITE PAVING DOT Sidewalk Concrete	Tilden Avenue	Saleh Al-Awgari	Fireman	
Yes	Potential Falling Debris	Loose ceiling tile is a potential safety hazard.	INTERIOR KITCHEN Ceiling	Near Sinks area	Saleh Al-Awgari	Fireman	
Yes	Protruding Elements	Exposed heating pipe is a potential tripping hazard.	INTERIOR STAIRS/RAMP S: INTERIOR Stairs and Landings	Stair DE/1	Saleh Al-Awgari	Fireman	
Yes	Protruding Elements	Exposed metal is a potential safety hazard.	INTERIOR GYMNASIUM Seating	Middle Bleachers	Saleh Al-Awgari	Fireman	

NYC Department of Education

Building Condition Assessment Survey 2023 - 2024

Architectural Inspection

K415

Yes	Tripping Hazard	Severely damaged quarry tile floor is a potential tripping hazard.	INTERIOR KITCHEN Floor Finish	Near ovens	Saleh Al-Awgari	Fireman
-----	-----------------	--	-----------------------------------	------------	-----------------	---------



Structural Engineer Required

Structural Condition Type	Condition Description	Component Affected	Location Description	Person(s) Notified	Person(s) Title	PhotoImage
No condition recorded						

Programmatic Accessibility

Programmatic Accessibility Status Question	Response
Is the primary or secondary entrance on an accessible route?	Yes
Is the building a multi-story building?	Yes
Are all floors of the building accessible through compliant means?	Yes
Accessible classrooms exists on each floor?	Yes
Boys and Girls or Unisex accessible toilets exist on at least every other floor?	Yes
If the following spaces exist, are they ALL accessible? Art Room, Auditorium, Cafeteria, Computer, Gymnasiums, Library, Multipurpose Room, Science Labs	Yes

Physical Breakdown Structure	Exists	Required	Complies	Deficiency	Assistive Fire Listening System	Fire Alarm Strobe
------------------------------	--------	----------	----------	------------	---------------------------------	-------------------

PROGRAMMATIC ACCESSIBILITY

Exterior Routes

Exterior Entrances & Exits			Yes			
Exterior H/C Lifts	No	No				
Exterior Ramps and Railings	No	No				

Interior Routes

Corridor and Lobby H/C Lifts	No	No				
Interior Corridor Doors and Hardware	Yes		Yes			
Interior Corridors and Lobbies			Yes			
Interior Elevators	Yes		Yes			
Interior Lobby Doors and Hardware			Yes			
Interior Ramps	Yes		Yes			

Rooms & Spaces

Art Rooms	Rooms B70, 221, 323	Yes	Yes			
Auditorium	1st Floor	Yes	No	H/C Lift Inoperable	FM System	Yes
Cafeteria	Basement	Yes	Yes		FM System	Yes
Classrooms	Basement, 1st-3rd Floors	Yes	Yes			
Computer Rooms	Rooms 203, 321	Yes	Yes			
Gymnasium	1st Floor - Gymnasium 1, 1st Floor - Gymnasium 2, 1st Floor - Gymnasium 3	Yes	Yes		FM System	Yes
Library	3rd Floor	Yes	Yes			
Main Office	Room 137 (It Takes a Village Academy); Room 232 (Kurt Hahn Expeditionary Learning School); Room 331A (Cultural Academy for the Arts and Sciences); Room 208 (Averyon Business Academy)	Yes	Yes			

**NYC Department of Education
Building Condition Assessment Survey 2023 - 2024**

Architectural Inspection

K415

Physical Breakdown Structure	Exists	Required	Complies	Deficiency	Assistive Listening System	Fire Alarm Strobe
Rooms & Spaces						
Multi-purpose Room	No					
Nurse's Room	Room B46	Yes	Yes			
Pool	Basement	Yes	Yes			
Science Lab	Rooms 140, 240, 241, 340	Yes	Yes			
Toilet Rooms (Boys)	Basement, 1st - 3rd Floors	Yes	Yes			
Toilet Rooms (Girls)	Basement, 1st - 3rd Floors	Yes	Yes			
Toilet Rooms (Staff)	Basement, 1st - 3rd Floors	Yes	Yes			

Building Template

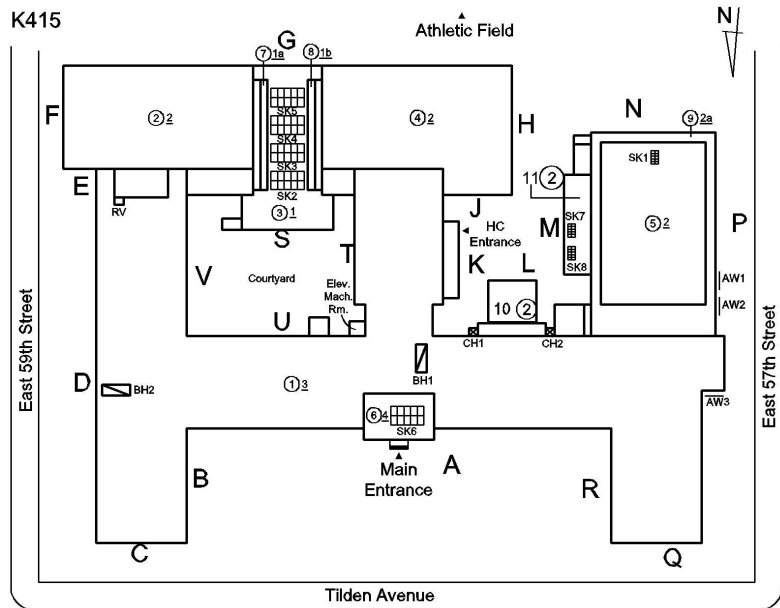

Inspection

Question	Response
Architectural	
EXTERIOR	Inspected
AREAWAY	Inspected
Instance on AW1 - AW3	Inspected
Instance Condition	3 - Fair
Instance Quantity	3
Instance Quantity Uom	EACH
Deficiency	AREAWAY WALLS: CRACKS AND SPALLING

**NYC Department of Education
Building Condition Assessment Survey 2023 - 2024**

Architectural Inspection

K415

Question

Response

EXTERIOR

AREAWAY

Roof Plan reference

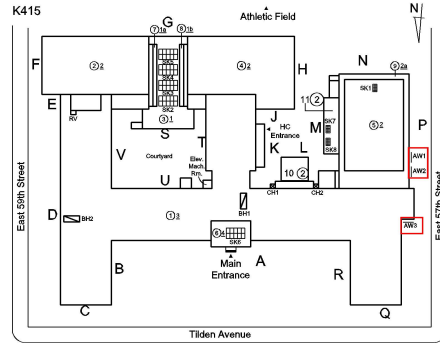

Deficiency Quantity

40

Quantity Uom

S.F.

Potential Action

REPLACE

Urgency of Action

PRIORITY 4

Purpose of Action

LEVEL 2

Deficiency Photo1



AW2

Violations

No violations recorded.

AWNINGS AND CANOPIES

Does not Exist

CHIMNEY

Inspected

Material Type(s)

Masonry

Condition

2 - Between Good and Fair

Deficiency

No deficiencies recorded

COPING

Inspected

Condition

1 - Good

Deficiency

No deficiencies recorded

CORNICE

Inspected

Condition

1 - Good

Deficiency

No deficiencies recorded

DOORS

Inspected

DOORS AND FRAMES

Inspected

Condition

5 - Poor

Deficiency

METAL: DETERIORATED DOOR AND FRAME - MAJOR DETERIORATION

**NYC Department of Education
Building Condition Assessment Survey 2023 - 2024**

Architectural Inspection

K415

Question

Response

EXTERIOR

DOORS

DOORS AND FRAMES

Roof Plan reference

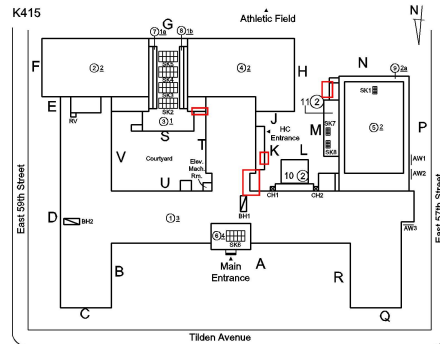

Deficiency Quantity
Quantity Uom
Potential Action
Urgency of Action
Purpose of Action
Deficiency Photo1

10
EACH
REPLACE
PRIORITY 4
LEVEL 2

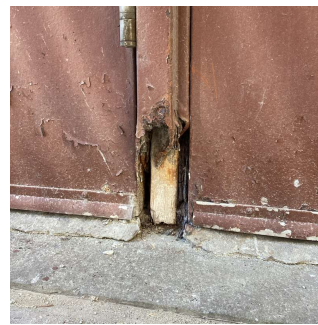

Facade M - Exit 9

Violations

No violations recorded.

Deficiency

ROLL-UP DOOR: DETERIORATED DOOR AND FRAME - MAJOR DETERIORATION

Roof Plan reference

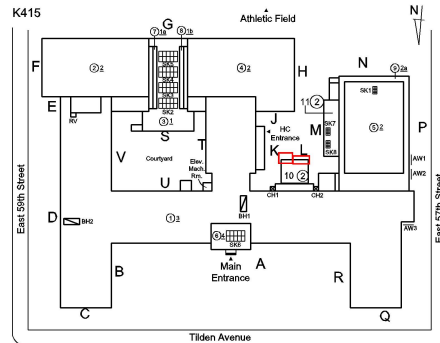

Deficiency Quantity
Quantity Uom
Potential Action
Urgency of Action
Purpose of Action

600
S.F.
REPLACE
PRIORITY 4
LEVEL 2

NYC Department of Education
Building Condition Assessment Survey 2023 - 2024

Architectural Inspection

K415

Question	Response
----------	----------

EXTERIOR

DOORS

DOORS AND FRAMES

Deficiency Photo1

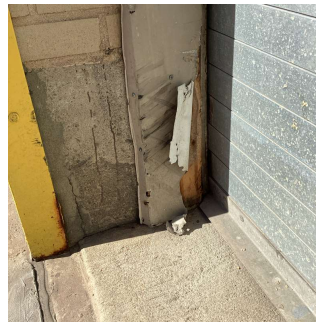

Facade L

No violations recorded.

Violations

DOOR HARDWARE

Inspected

Condition

3 - Fair

Deficiency

No deficiencies recorded

LINTELS

Inspected

Condition

2 - Between Good and Fair

Deficiency

No deficiencies recorded

TRANSOM/SIDE LIGHT

Inspected

Condition

2 - Between Good and Fair

Deficiency

No deficiencies recorded

EXTERIOR WALLS

Inspected

Material Type(s)

Masonry

Replacement Quantity

80,000

Replacement Uom

S.F.

Instance on All Facades

Inspected

Instance Condition

3 - Fair

Instance Quantity

80,000

Instance Quantity Uom

S.F.

Deficiency

BRICK: DETERIORATED JOINTS

Roof Plan reference

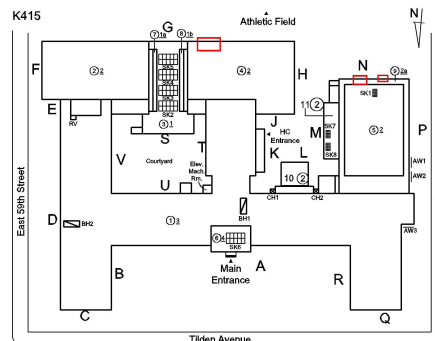

**NYC Department of Education
Building Condition Assessment Survey 2023 - 2024**

Architectural Inspection

K415

Question

Response

EXTERIOR

EXTERIOR WALLS

Elevation

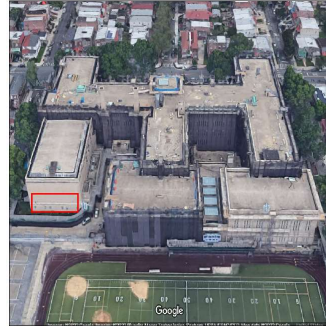

Deficiency Quantity

40

Quantity Uom

S.F.

Potential Action

REPOINT

Urgency of Action

PRIORITY 3

Purpose of Action

LEVEL 2

Deficiency Photo1

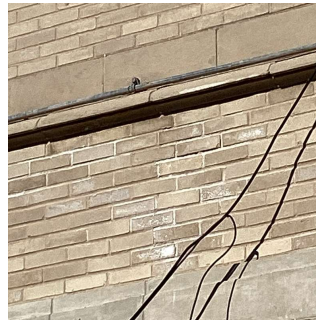

Facade N

Violations

No violations recorded.

Deficiency

BRICK: MINOR CRACKS AND SPALLING

Roof Plan reference

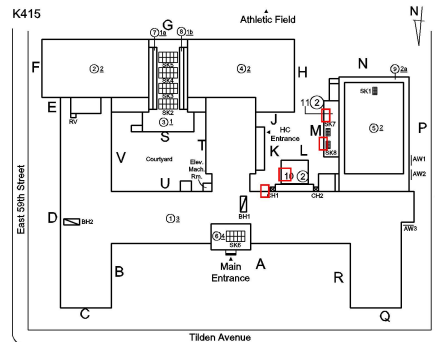

Elevation



Deficiency Quantity

50

Quantity Uom

S.F.

Potential Action

RESTITCH

**NYC Department of Education
Building Condition Assessment Survey 2023 - 2024**

Architectural Inspection

K415

Question

Response

EXTERIOR

EXTERIOR WALLS

Urgency of Action
Purpose of Action
Deficiency Photo1

PRIORITY 3
LEVEL 2

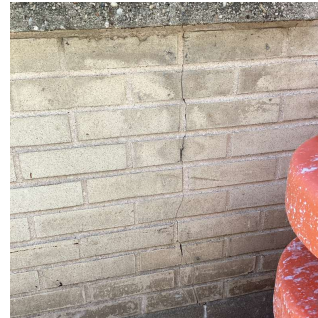

Facade M

Violations

No violations recorded.

Deficiency

BRICK: DETERIORATED MASONRY SILLS - MINOR

Roof Plan reference

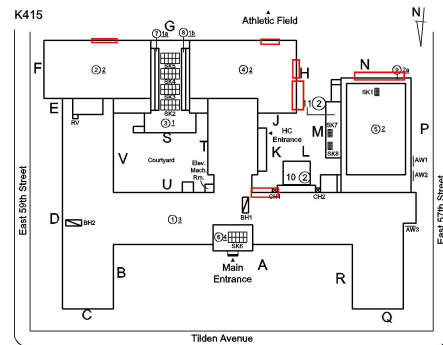

Elevation



Deficiency Quantity

70

Quantity Uom

L.F.

Potential Action

REPAIR

Urgency of Action

PRIORITY 3

Purpose of Action

LEVEL 2

Deficiency Photo1



Facade N

**NYC Department of Education
Building Condition Assessment Survey 2023 - 2024**

Architectural Inspection

K415

Question

Response

EXTERIOR

EXTERIOR WALLS

Violations

No violations recorded.

Deficiency

BRICK: DETERIORATED JOINTS

Roof Plan reference

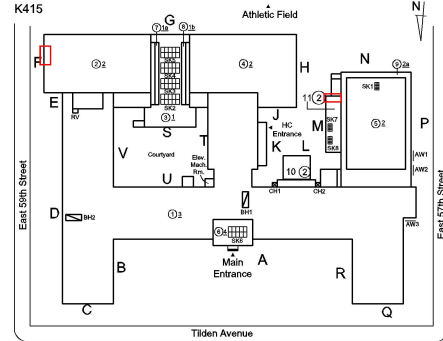

Elevation

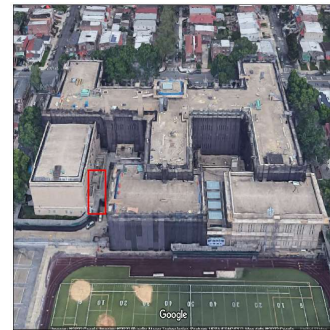

Deficiency Quantity

40

Quantity Uom

S.F.

Potential Action

REPOINT

Urgency of Action

PRIORITY 4

Purpose of Action

LEVEL 2

Deficiency Photo1



Facade F

Violations

No violations recorded.

Deficiency

TERRA COTTA: CHIPPED/SPALLED/BROKEN PIECES - MINOR

Roof Plan reference

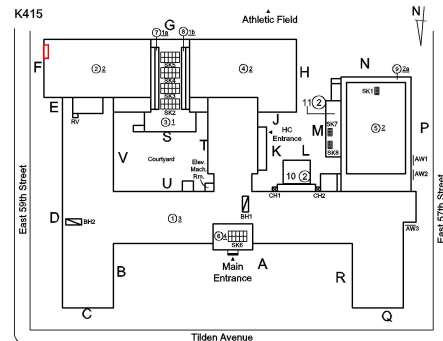

**NYC Department of Education
Building Condition Assessment Survey 2023 - 2024**

Architectural Inspection

K415

Question

Response

EXTERIOR

EXTERIOR WALLS

Elevation

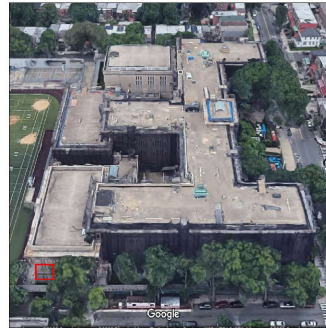

Deficiency Quantity

10

Quantity Uom

S.F.

Potential Action

REPAIR

Urgency of Action

PRIORITY 3

Purpose of Action

LEVEL 2

Deficiency Photo1



Facade F

Violations

No violations recorded.

Deficiency

BRICK: MAJOR / THRU CRACKS

Roof Plan reference

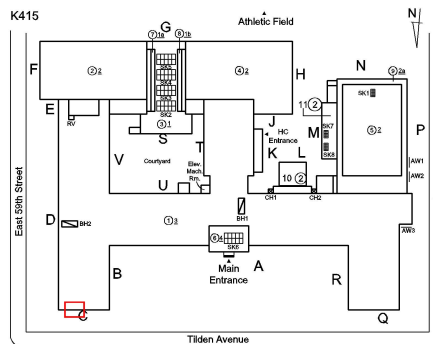

Elevation

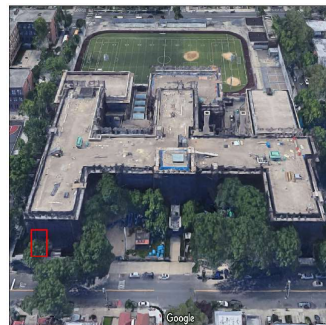

Deficiency Quantity

30

Quantity Uom

S.F.

Potential Action

REMOVE AND REBUILD

**NYC Department of Education
Building Condition Assessment Survey 2023 - 2024**

Architectural Inspection

K415

Question	Response
----------	----------

EXTERIOR
EXTERIOR WALLS

Urgency of Action
Purpose of Action
Deficiency Photo1

PRIORITY 4
LEVEL 2



Facade C

Violations

No violations recorded.

EXTERIOR SOFFITS

Does not Exist

LOADING DOCK

Does not Exist

LOUVER

Inspected

Condition

2 - Between Good and Fair

Deficiency

No deficiencies recorded

PARAPETS

Inspected

Material Type(s)

Masonry

Replacement Quantity

12,000

Replacement Uom

C.F.

Instance on All Facades

Inspected

Instance Condition

3 - Fair

Instance Quantity

12,000

Instance Quantity Uom

C.F.

Deficiency

BRICK: DETERIORATED JOINTS

Roof Plan reference

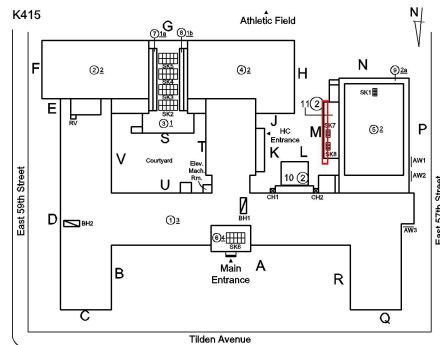

Deficiency Quantity

40

Quantity Uom

S.F.

Potential Action

REPOINT

Urgency of Action

PRIORITY 3

Purpose of Action

LEVEL 2

NYC Department of Education
Building Condition Assessment Survey 2023 - 2024

Architectural Inspection

K415

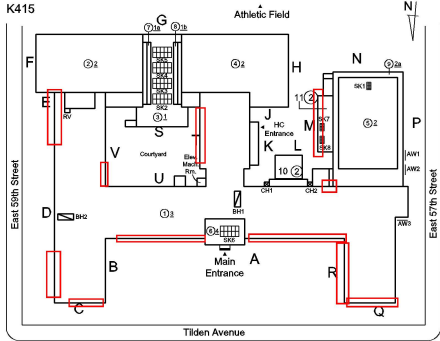
Question	Response
EXTERIOR	
PARAPETS	
Deficiency Photo1	
Violations	Roof 11 No violations recorded.
Deficiency	BRICK: EFFLORESCENCE
Roof Plan reference	
Deficiency Quantity	100
Quantity Uom	S.F.
Potential Action	MAINTENANCE
Urgency of Action	PRIORITY 1
Purpose of Action	LEVEL 1
Deficiency Photo1	No photo recorded
Violations	No violations recorded.
PLAZA DECK	Does not Exist
ROOF	Inspected
Roofing	Inspected
Replacement Quantity	86,000
Replacement Uom	S.F.
ROOF HATCH/SMOKE HATCH	Does not Exist
LEADERS, GUTTERS, DOWNSPOUTS, SCUPPERS	Inspected
Condition	2 - Between Good and Fair
Deficiency	No deficiencies recorded
ROOF BARRIER/FENCE	Inspected
Condition	2 - Between Good and Fair
Deficiency	No deficiencies recorded
ROOF CAGE	Does not Exist
ROOFING	Inspected
Instance on Modified Bitumen: Roofs 1-6	Inspected
Instance Condition	1 - Good

NYC Department of Education
Building Condition Assessment Survey 2023 - 2024

Architectural Inspection

K415

Question	Response
EXTERIOR	
ROOF	
Roofing	
ROOFING	
Instance Photo	
	Roof 1
Instance Quantity	84,500
Instance Quantity Uom	S.F.
Does the roof have major mechanical equipment sitting on Dunnage Steel less than 18" above the Roofing?	No
Does this roof instance have a Sustainable Roof System?	Yes
Sustainable Roof Type	White Roof
Sustainable Roof Location (Roof Number)	Roofs 1-6
Do solar panels exist on these roofs?	No
Is/Are the roof(s) suitable for Solar Panel installation?	Yes
Installation Year	2023
Source of Installation	Custodial Staff
Deficiency	No deficiencies recorded
Instance on Metal: Roofs 7-9	Inspected
Instance Condition	1 - Good
Instance Photo	
	Roof 9
Instance Quantity	1,500
Instance Quantity Uom	S.F.
Does the roof have major mechanical equipment sitting on Dunnage Steel less than 18" above the Roofing?	No
Does this roof instance have a Sustainable Roof System?	No
Do solar panels exist on these roofs?	No
Is/Are the roof(s) suitable for Solar Panel installation?	No
Installation Year	2023
Source of Installation	Custodial Staff
Deficiency	No deficiencies recorded
ROOFING DRAINS	Inspected
Condition	1 - Good
Deficiency	No deficiencies recorded
Specialties	Inspected
BULKHEAD/PENTHOUSE	Inspected
Condition	2 - Between Good and Fair
Deficiency	BULKHEAD/PENTHOUSE WALLS/EXTERIOR: CRACKS/SPALLING - MINOR

**NYC Department of Education
Building Condition Assessment Survey 2023 - 2024**

Architectural Inspection

K415

Question **Response**

EXTERIOR

ROOF

Specialties

BULKHEAD/PENTHOUSE

Roof Plan reference

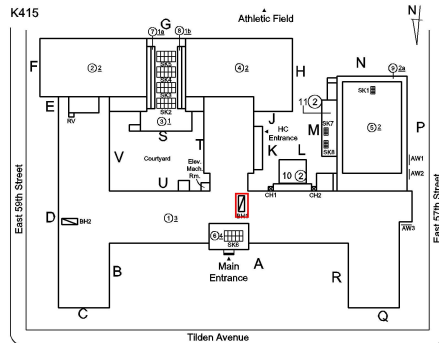

Deficiency Quantity
Quantity Uom
Potential Action
Urgency of Action
Purpose of Action
Deficiency Photo1

10
S.F.
REPAIR
PRIORITY 3
LEVEL 2



BH1
No violations recorded.

Violations

CUPOLA/ SPIRES/ TOWERS	Does not Exist
DORMER	Does not Exist
DUNNAGE STEEL	Does not Exist
SKYLIGHT/ROOF VENT	Inspected
Material Type(s)	Plastic
Condition	2 - Between Good and Fair
Deficiency	No deficiencies recorded
ROOF/GRAVITY TANK	Does not Exist
STAIRS/RAMPS: EXTERIOR	Inspected
BUILDING CHEEK/FLANK WALLS	Inspected
Condition	2 - Between Good and Fair
Deficiency	No deficiencies recorded
RAILINGS	Inspected
Condition	5 - Poor
Deficiency	MISSING RAILING

**NYC Department of Education
Building Condition Assessment Survey 2023 - 2024**

Architectural Inspection

K415

Question

Response

EXTERIOR

STAIRS/RAMPS: EXTERIOR

RAILINGS

Roof Plan reference

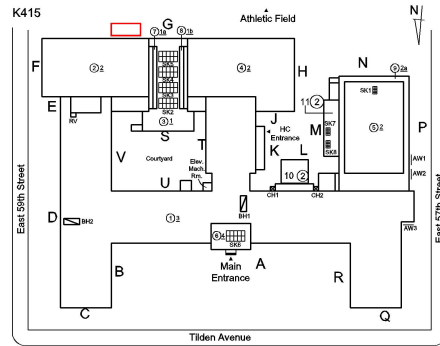

Deficiency Quantity
Quantity Uom
Potential Action
Urgency of Action
Purpose of Action
Deficiency Photo1

10
L.F.
REPLACE
PRIORITY 5
LEVEL 6

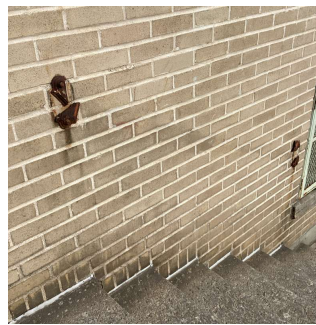

Facade G
No violations recorded.

Violations

Deficiency

Roof Plan reference

DAMAGED

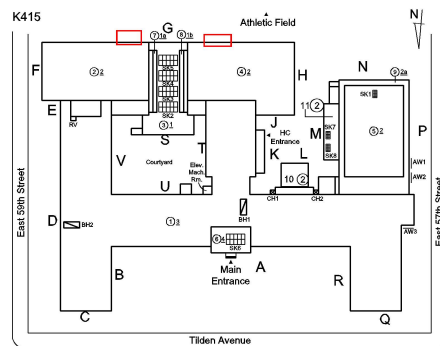

Deficiency Quantity
Quantity Uom
Potential Action
Urgency of Action
Purpose of Action

20
L.F.
REPLACE
PRIORITY 4
LEVEL 2

**NYC Department of Education
Building Condition Assessment Survey 2023 - 2024**

Architectural Inspection

K415

Question

Response

EXTERIOR

STAIRS/RAMPS: EXTERIOR

RAILINGS

Deficiency Photo1

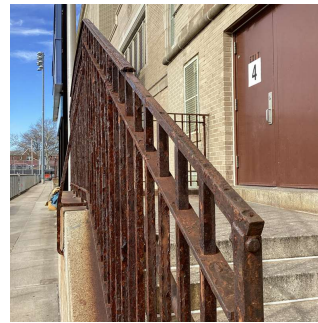

Facade G

No violations recorded.

Violations

Deficiency

Roof Plan reference

BROKEN BRACKET

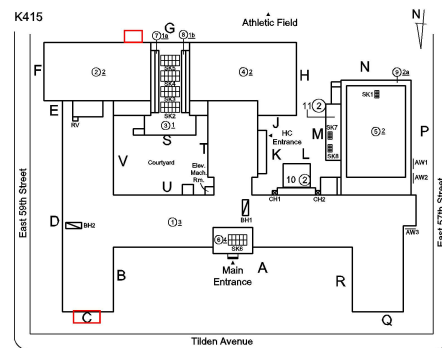

2

EACH

REPLACE

PRIORITY 4

LEVEL 2

Deficiency Quantity

Quantity Uom

Potential Action

Urgency of Action

Purpose of Action

Deficiency Photo1



Facade G

No violations recorded.

Violations

Deficiency

RUST - MAJOR

**NYC Department of Education
Building Condition Assessment Survey 2023 - 2024**

Architectural Inspection

K415

Question

Response

EXTERIOR

STAIRS/RAMPS: EXTERIOR

RAILINGS

Roof Plan reference

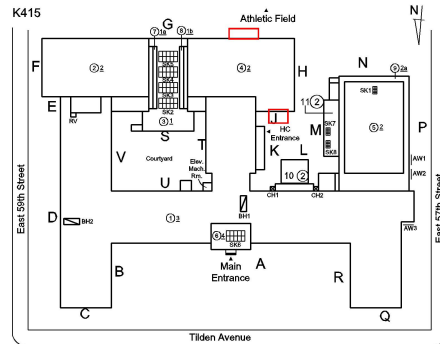

Deficiency Quantity
Quantity Uom
Potential Action
Urgency of Action
Purpose of Action
Deficiency Photo1

20
L.F.
REPLACE
PRIORITY 4
LEVEL 2



Facade J
No violations recorded.

Violations

STAIRS/RAMPS

Condition

Inspected

Deficiency

5 - Poor

Roof Plan reference

STONE: CRACKS/SPALLING - MINOR

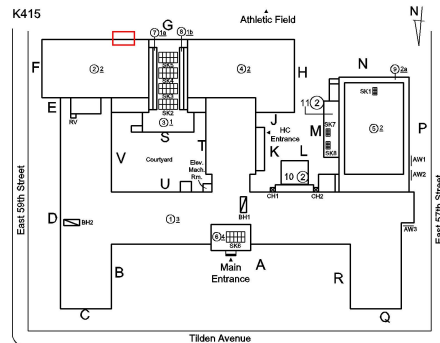

Deficiency Quantity
Quantity Uom
Potential Action
Urgency of Action
Purpose of Action

10
S.F.
REPAIR
PRIORITY 3
LEVEL 2

**NYC Department of Education
Building Condition Assessment Survey 2023 - 2024**

Architectural Inspection

K415

Question

Response

EXTERIOR

STAIRS/RAMPS: EXTERIOR

STAIRS/RAMPS

Deficiency Photo1

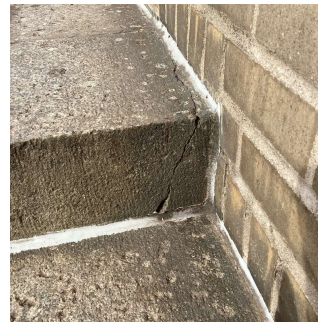

Facade G

No violations recorded.

Violations

Deficiency

Roof Plan reference

STONE: DETERIORATED JOINTS

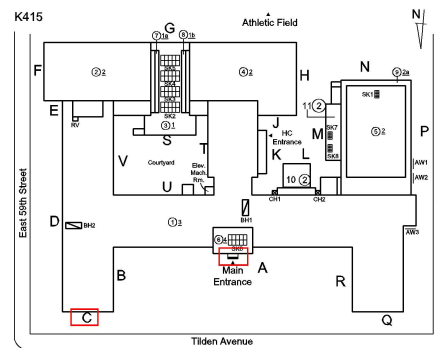

10

L.F.

REPOINT

PRIORITY 4

LEVEL 2

Deficiency Quantity

Quantity Uom

Potential Action

Urgency of Action

Purpose of Action

Deficiency Photo1



Facade A

No violations recorded.

Violations

Deficiency

STONE: CRACKS/SPALLING - MAJOR

**NYC Department of Education
Building Condition Assessment Survey 2023 - 2024**

Architectural Inspection

K415

Question

Response

EXTERIOR

STAIRS/RAMPS: EXTERIOR

STAIRS/RAMPS

Roof Plan reference

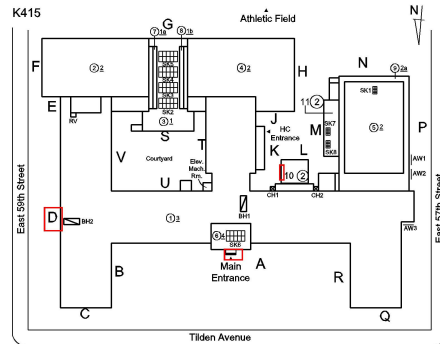

Deficiency Quantity
Quantity Uom
Potential Action
Urgency of Action
Purpose of Action
Deficiency Photo1

20
S.F.
REPLACE
PRIORITY 4
LEVEL 2



Facade A
No violations recorded.

Violations

WINDOWS

Inspected

Replacement Quantity

22,000

Replacement Uom

S.F.

EXTERIOR GUARDS

Inspected

Condition

3 - Fair

Deficiency

RUST - MAJOR

Roof Plan reference

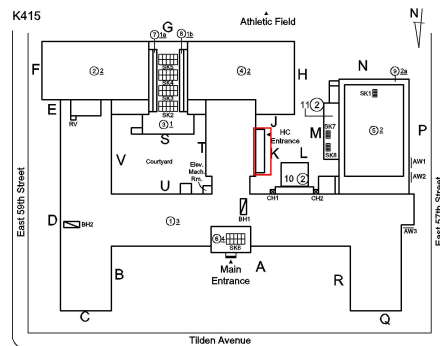

**NYC Department of Education
Building Condition Assessment Survey 2023 - 2024**

Architectural Inspection

K415

Question

Response

EXTERIOR

WINDOWS

EXTERIOR GUARDS

Elevation



Deficiency Quantity
Quantity Uom
Potential Action
Urgency of Action
Purpose of Action
Deficiency Photo1

60
S.F.
REPLACE
PRIORITY 4
LEVEL 2



Facade K

No violations recorded.

Violations

Deficiency

Roof Plan reference

DETERIORATED/TORN-OUT/MISSING

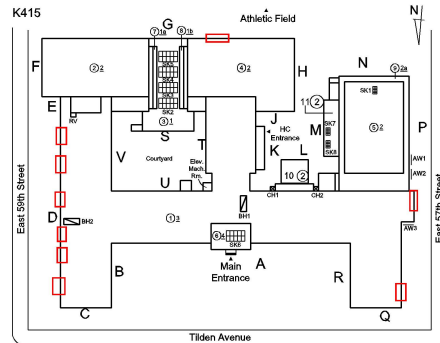

Elevation

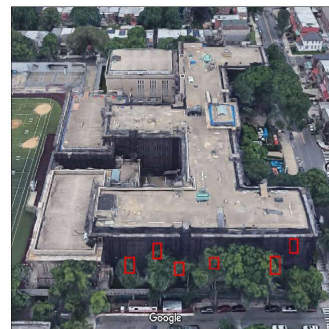



Deficiency Quantity
Quantity Uom

120
S.F.

**NYC Department of Education
Building Condition Assessment Survey 2023 - 2024**

Architectural Inspection

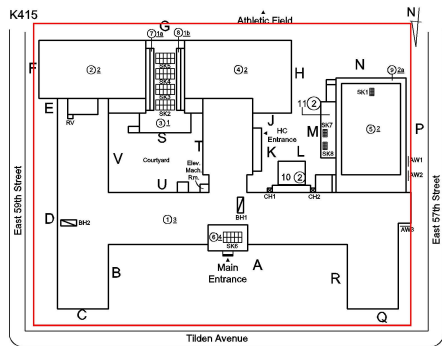
K415

Question	Response
EXTERIOR	
WINDOWS	
EXTERIOR GUARDS	
Potential Action	REPLACE
Urgency of Action	PRIORITY 4
Purpose of Action	LEVEL 2
Deficiency Photo1	
Violations	Facade D No violations recorded.
LINTELS	Inspected
Condition	2 - Between Good and Fair
Deficiency	No deficiencies recorded
WINDOWS	Inspected
Material Type(s)	Aluminum
Instance on Aluminum - Double Hung: All Facades	Inspected
Instance Condition	3 - Fair
Instance Quantity	21,900
Instance Quantity Uom	S.F.
Are these windows insulated	No
Installation Year	2002
Source of Installation	Custodial Staff
Deficiency	ALUMINUM - DOUBLE HUNG: INOPERABLE BALANCE
Roof Plan reference	
Elevation	
Deficiency Quantity	100

NYC Department of Education
Building Condition Assessment Survey 2023 - 2024

Architectural Inspection

K415

Question	Response
EXTERIOR	
WINDOWS	
WINDOWS	
Quantity Uom	EACH
Potential Action	REPLACE BALANCES
Urgency of Action	PRIORITY 3
Purpose of Action	LEVEL 2
Deficiency Photo	No photo recorded
Violations	No violations recorded.
Instance on Aluminum - Other: Facade G	Inspected
Instance Condition	3 - Fair
Instance Quantity	100
Instance Quantity Uom	S.F.
Are these windows insulated	No
Installation Year	2002
Source of Installation	Custodial Staff
Deficiency	No deficiencies recorded
INTERIOR	Inspected
POOLS	Inspected
Instance on Basement	Inspected
CEILING	
Instance on Basement	Inaccessible
DECK/FLOOR	
Instance on Basement	Inaccessible
DIVING BOARD/PLATFORM	
Instance on Basement	Does not Exist
POOL LINING	
Instance on Basement	Inaccessible
POOL STRUCTURE	
Instance on Basement	Inaccessible
SEATING	
Instance on Basement	Inaccessible
WALLS	
Instance on Basement	Inaccessible
STRUCTURAL	Inspected
COLUMNS/BEAMS/BEARING WALLS	Inspected
Condition	3 - Fair
Deficiency	STEEL COLUMNS/BEAMS: DETERIORATED CONCRETE FIREPROOFING
Deficiency Location/Instance	AW2
Deficiency Quantity	20
Quantity Uom	S.F.
Potential Action	REPLACE
Urgency of Action	PRIORITY 4
Purpose of Action	LEVEL 5

**NYC Department of Education
Building Condition Assessment Survey 2023 - 2024**

Architectural Inspection



K415

Question	Response
INTERIOR	
STRUCTURAL	
COLUMNS/BEAMS/BEARING WALLS	
Deficiency Photo1	
Violations	AW2 No violations recorded.
Deficiency	STEEL COLUMNS/BEAMS: DETERIORATED CONCRETE FIREPROOFING
Deficiency Location/Instance	Basement - Columns
Deficiency Quantity	40
Quantity Uom	S.F.
Potential Action	REPLACE
Urgency of Action	PRIORITY 3
Purpose of Action	LEVEL 5
Deficiency Photo1	
Violations	Basement - Boiler Room No violations recorded.
FLOOR STRUCTURE	Inspected
Condition	3 - Fair
Deficiency	CONCRETE SLAB ON GRADE: THRU CRACKS
Deficiency Location/Instance	Boiler Room
Deficiency Quantity	60
Quantity Uom	S.F.
Potential Action	REPAIR
Urgency of Action	PRIORITY 3
Purpose of Action	LEVEL 5

**NYC Department of Education
Building Condition Assessment Survey 2023 - 2024**

Architectural Inspection



K415

Question	Response
INTERIOR	
STRUCTURAL	
FLOOR STRUCTURE	
Deficiency Photo1	
Violations	Boiler Room No violations recorded.
Deficiency	CONCRETE SLAB ON GRADE: THRU CRACKS
Deficiency Location/Instance	Boiler Room
Deficiency Quantity	40
Quantity Uom	S.F.
Potential Action	REPLACE
Urgency of Action	PRIORITY 4
Purpose of Action	LEVEL 5
Deficiency Photo1	
Violations	Boiler Room No violations recorded.
FOUNDATION WALLS	
Material Type(s)	Inspected Concrete, Masonry
Condition	3 - Fair
Deficiency	CONCRETE: CRACKED/SPALLED/REINFORCEMENT EXPOSED
Deficiency Location/Instance	Basement - Gas Meter Room, Storage
Deficiency Quantity	40
Quantity Uom	S.F.
Potential Action	REPAIR
Urgency of Action	PRIORITY 3
Purpose of Action	LEVEL 5

**NYC Department of Education
Building Condition Assessment Survey 2023 - 2024**

Architectural Inspection

K415

Question	Response
INTERIOR	
STRUCTURAL	
FOUNDATION WALLS	Inspected
Deficiency Photo1	
Violations	Basement - Gas Meter Room No violations recorded.
ROOF STRUCTURE	
Condition	Inspected 3 - Fair
Deficiency	CONCRETE: CRACKED/SPALLED/REINFORCEMENT EXPOSED
Deficiency Location/Instance	Roof 1 - Library Mechanical Room
Deficiency Quantity	10
Quantity Uom	S.F.
Potential Action	REPAIR
Urgency of Action	PRIORITY 4
Purpose of Action	LEVEL 5
Deficiency Photo1	
Violations	Roof 1 - Library Mechanical Room No violations recorded.
VAULTS-BUNKERS	Does not Exist
AUDITORIUM	
Instance on 1st Floor (1297 Seats)	Inspected
Ceiling	Inspected
Instance on 1st Floor (1297 Seats)	Inspected
Condition	2 - Between Good and Fair
Deficiency	No deficiencies recorded
Door(s)	
Instance on 1st Floor (1297 Seats)	Inspected
Condition	4 - Between Fair and Poor
Deficiency	WOOD: DETERIORATED DOOR AND FRAME
Deficiency Location/Instance	Main Entrance
Deficiency Quantity	2
Quantity Uom	EACH
Potential Action	MAINTENANCE

**NYC Department of Education
Building Condition Assessment Survey 2023 - 2024**

Architectural Inspection

K415

Question	Response
INTERIOR	
AUDITORIUM	
Door(s)	
Urgency of Action	PRIORITY 3
Purpose of Action	LEVEL 2
Deficiency Photo1	
	Main Entrance
Violations	No violations recorded.
Fixed H/C Lift	
Instance on 1st Floor (1297 Seats)	Inspected
Condition	5 - Poor
Deficiency	INOPERABLE
Deficiency Location/Instance	Right Side
Deficiency Quantity	1
Quantity Uom	EACH
Potential Action	REPLACE
Urgency of Action	PRIORITY 3
Purpose of Action	LEVEL 2
Deficiency Photo1	No photo recorded
Violations	No violations recorded.
Fixed Seating	
Instance on 1st Floor (1297 Seats)	Inspected
Condition	2 - Between Good and Fair
Deficiency	DAMAGED/BROKEN/INOPERABLE
Deficiency Location/Instance	Seat W/19
Deficiency Quantity	1
Quantity Uom	EACH
Potential Action	REPLACE
Urgency of Action	PRIORITY 5
Purpose of Action	LEVEL 6
Deficiency Photo1	
	Seat W/19
Violations	No violations recorded.
Deficiency	DAMAGED/BROKEN/INOPERABLE

**NYC Department of Education
Building Condition Assessment Survey 2023 - 2024**

Architectural Inspection

K415

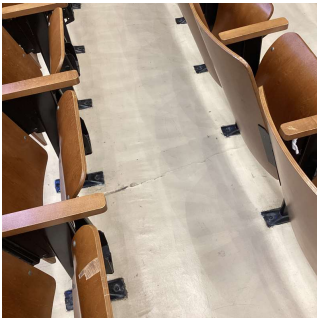
Question	Response
INTERIOR	
AUDITORIUM	
Fixed Seating	
Deficiency Location/Instance	Seats A/103, 104, B/101, D/1, T/1 and others
Deficiency Quantity	9
Quantity Uom	EACH
Potential Action	REPLACE
Urgency of Action	PRIORITY 3
Purpose of Action	LEVEL 2
Deficiency Photo1	
Violations	Seat D/1 No violations recorded.
Floor Finish	
Instance on 1st Floor (1297 Seats)	Inspected
Condition	2 - Between Good and Fair
Deficiency	CONCRETE: CRACKS
Deficiency Location/Instance	Near Seat D/3, 20, 2nd Floor Balcony
Deficiency Quantity	75
Quantity Uom	S.F.
Potential Action	REPLACE
Urgency of Action	PRIORITY 3
Purpose of Action	LEVEL 2
Deficiency Photo1	
Violations	Near Seat D/3 No violations recorded.
Sliding-folding Partition	
Instance on 1st Floor (1297 Seats)	Does not Exist
Stage	
Instance on 1st Floor (1297 Seats)	Inspected
Stage	Inspected
Instance on 1st Floor (1297 Seats)	Inspected
Condition	3 - Fair
Deficiency	DAMAGED FLOOR
Deficiency Location/Instance	Left Side, Rear Left Side

**NYC Department of Education
Building Condition Assessment Survey 2023 - 2024**

Architectural Inspection

K415

Question	Response
INTERIOR	
AUDITORIUM	
Stage	
Stage	
Deficiency Quantity	20
Quantity Uom	S.F.
Potential Action	REPLACE
Urgency of Action	PRIORITY 3
Purpose of Action	LEVEL 2
Deficiency Photo1	
	Left Side
Violations	No violations recorded.
Deficiency	DAMAGED FASCIA
Deficiency Location/Instance	Front
Deficiency Quantity	10
Quantity Uom	S.F.
Potential Action	REPLACE
Urgency of Action	PRIORITY 3
Purpose of Action	LEVEL 2
Deficiency Photo1	
	Front
Violations	No violations recorded.
Stage Curtain Rigging	Inspected
Instance on 1st Floor (1297 Seats)	Inspected
Condition	1 - Good
Deficiency	No deficiencies recorded
Stage Curtains	Inspected
Instance on 1st Floor (1297 Seats)	Inspected
Condition	2 - Between Good and Fair
Deficiency	No deficiencies recorded
Walls	
Instance on 1st Floor (1297 Seats)	Inspected
Condition	2 - Between Good and Fair
Deficiency	PLASTER: CRACKS/SPALLING

NYC Department of Education
Building Condition Assessment Survey 2023 - 2024

Architectural Inspection

K415

Question	Response
INTERIOR	
AUDITORIUM	
Walls	
Deficiency Location/Instance	Left Side, Near Entrance, near Exit, 2nd Floor balcony Near Windows
Deficiency Quantity	40
Quantity Uom	S.F.
Potential Action	REPLACE
Urgency of Action	PRIORITY 3
Purpose of Action	LEVEL 2
Deficiency Photo1	
Violations	Left Side No violations recorded.
STONE MOLDINGS: CRACKS/SPALLING	
Deficiency Location/Instance	Right side of Stage, Left and Right Side Near Windows, Near Entrance
Deficiency Quantity	60
Quantity Uom	L.F.
Potential Action	REPLACE
Urgency of Action	PRIORITY 3
Purpose of Action	LEVEL 2
Deficiency Photo1	
Violations	Right side of Stage No violations recorded.
Window Curtains/Shades/Blinds	
Instance on 1st Floor (1297 Seats)	Inspected
Condition	2 - Between Good and Fair
Deficiency	No deficiencies recorded
CAFETERIA	
Instance on Basement	Inspected
Ceiling	
Instance on Basement	Inspected
Condition	3 - Fair
Deficiency	ACOUSTIC TILES: DAMAGED/MISSING
Deficiency Location/Instance	Left and Right Side Near Windows, center, Near Stair A, Near Serving area and others

**NYC Department of Education
Building Condition Assessment Survey 2023 - 2024**

Architectural Inspection

K415

Question	Response
----------	----------

INTERIOR

CAFETERIA

Ceiling

Deficiency Quantity	160
Quantity Uom	S.F.
Potential Action	REPLACE
Urgency of Action	PRIORITY 3
Purpose of Action	LEVEL 2
Deficiency Photo1	

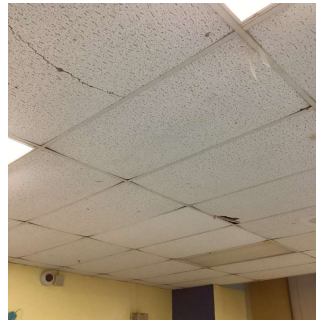

Left Side Near Windows
No violations recorded.

Violations

Door(s)

Instance on Basement	Inspected
Condition	3 - Fair
Deficiency	METAL: DETERIORATED DOOR
Deficiency Location/Instance	Main Entrance
Deficiency Quantity	1
Quantity Uom	EACH
Potential Action	MAINTENANCE
Urgency of Action	PRIORITY 3
Purpose of Action	LEVEL 2
Deficiency Photo1	

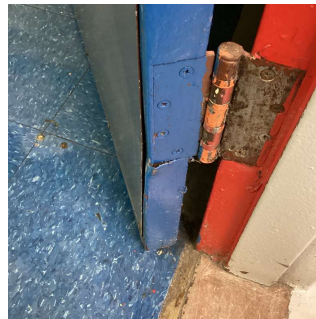

Main Entrance

No violations recorded.

Violations

Fixed Equipment

Instance on Basement	Does not Exist
----------------------	----------------

Floor Finish

Instance on Basement	Inspected
Condition	4 - Between Fair and Poor
Deficiency	VINYL TILES: DETERIORATED SUBSTRATE
Deficiency Location/Instance	Left and Right Side Near Windows, Near Stairs A, B, Near Serving area and others
Deficiency Quantity	300
Quantity Uom	S.F.

NYC Department of Education
Building Condition Assessment Survey 2023 - 2024

Architectural Inspection

K415

Question	Response
INTERIOR	
CAFETERIA	
Floor Finish	
Potential Action	REPLACE
Urgency of Action	PRIORITY 3
Purpose of Action	LEVEL 2
Deficiency Photo1	
	Left Side Near Windows
Violations	No violations recorded.
Deficiency	VINYL TILES: BROKEN/DETERIORATED/MISSING TILES
Deficiency Location/Instance	Near Stairs H, D
Deficiency Quantity	20
Quantity Uom	S.F.
Potential Action	REPLACE
Urgency of Action	PRIORITY 3
Purpose of Action	LEVEL 2
Deficiency Photo1	
	Near Stair H
Violations	No violations recorded.
Sliding-folding Partition	
Instance on Basement	Does not Exist
Stage	
Instance on Basement	Does not Exist
Walls	
Instance on Basement	Inspected
Condition	3 - Fair
Deficiency	PLASTER: CRACKS/SPALLING
Deficiency Location/Instance	Left and Right Side Near Windows, Center Near Windows, Near Stairs A, B and others
Deficiency Quantity	150
Quantity Uom	S.F.
Potential Action	REPLACE
Urgency of Action	PRIORITY 3
Purpose of Action	LEVEL 2

**NYC Department of Education
Building Condition Assessment Survey 2023 - 2024**

Architectural Inspection

K415

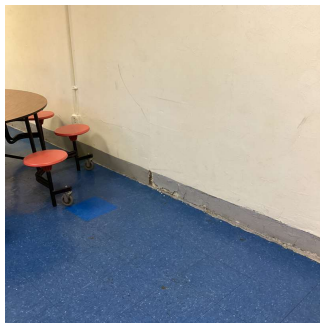
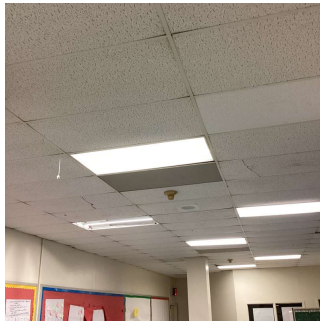
Question	Response
INTERIOR	
CAFETERIA	
Walls	
Deficiency Photo1	
	Near Stair A
Violations	No violations recorded.
Window Curtains/Shades/Blinds	
Instance on Basement	Does not Exist
CLASSROOMS/CORRIDORS/ADMIN SPACES	
Ceiling	Inspected
Condition	2 - Between Good and Fair
Deficiency	ACOUSTIC TILES: DAMAGED/MISSING
Deficiency Location/Instance	Room B30
Deficiency Quantity	20
Quantity Uom	S.F.
Potential Action	REPLACE
Urgency of Action	PRIORITY 3
Purpose of Action	LEVEL 2
Deficiency Photo1	
	Room B30
Violations	No violations recorded.
Deficiency	PLASTER: CRACKS/SPALLING
Deficiency Location/Instance	Corridor near Room 318A
Deficiency Quantity	20
Quantity Uom	S.F.
Potential Action	REPLACE
Urgency of Action	PRIORITY 3
Purpose of Action	LEVEL 2

**NYC Department of Education
Building Condition Assessment Survey 2023 - 2024**

Architectural Inspection

K415

Question	Response
----------	----------

INTERIOR

CLASSROOMS/CORRIDORS/ADMIN SPACES

Ceiling

Deficiency Photo1



Corridor near Room 318A

Violations

No violations recorded.

Door(s)

Inspected

Condition

5 - Poor

Deficiency

WOOD: DETERIORATED DOOR

Deficiency Location/Instance

Rooms 350, 346, 345, 333, 332 and others

Deficiency Quantity

35

Quantity Uom

EACH

Potential Action

MAINTENANCE

Urgency of Action

PRIORITY 3

Purpose of Action

LEVEL 2

Deficiency Photo1



Room 350

Violations

No violations recorded.

Floor Finish

Inspected

Condition

3 - Fair

Deficiency

EPOXY FLOORING: CRACKS/SPALLING

Deficiency Location/Instance

Rooms 241, 240A, 240, 140A

Deficiency Quantity

150

Quantity Uom

S.F.

Potential Action

REPLACE

Urgency of Action

PRIORITY 3

Purpose of Action

LEVEL 2

**NYC Department of Education
Building Condition Assessment Survey 2023 - 2024**

Architectural Inspection

K415

Question	Response
INTERIOR	
CLASSROOMS/CORRIDORS/ADMIN SPACES	
Floor Finish	
Deficiency	TERRAZZO: CRACKS
Deficiency Location/Instance	Main Entrance Lobby, Corridor near Rooms 149, 127, 124, Corridor near Auditorium and others
Deficiency Quantity	250
Quantity Uom	S.F.
Potential Action	REPLACE
Urgency of Action	PRIORITY 3
Purpose of Action	LEVEL 2
Deficiency Photo1	
Violations	Main Entrance Lobby No violations recorded.
Walls	
Condition	Inspected 2 - Between Good and Fair
Deficiency	STONE: CRACKS/SPALLING
Deficiency Location/Instance	Corridor near Rooms 151, 148, 142, 127, 111 and others
Deficiency Quantity	150
Quantity Uom	S.F.
Potential Action	REPLACE
Urgency of Action	PRIORITY 3
Purpose of Action	LEVEL 2
Deficiency Photo1	
Violations	Corridor near Room 151 No violations recorded.
Deficiency	PLASTER: CRACKS/SPALLING
Deficiency Location/Instance	Corridor near Rooms 350, 345A, 329, 328, Room 241 and others
Deficiency Quantity	250
Quantity Uom	S.F.
Potential Action	REPLACE
Urgency of Action	PRIORITY 3
Purpose of Action	LEVEL 2

**NYC Department of Education
Building Condition Assessment Survey 2023 - 2024**

Architectural Inspection

K415

Question	Response
INTERIOR	
CLASSROOMS/CORRIDORS/ADMIN SPACES	
Walls	
Deficiency Photo1	
Violations	Corridor near Room 328 No violations recorded.
Specialties	Inspected
Classroom Locker(s)	Inspected
Condition	2 - Between Good and Fair
Deficiency	No deficiencies recorded
Fixed Seating	Inspected
Condition	4 - Between Fair and Poor
Deficiency	DAMAGED/BROKEN/INOPERABLE
Deficiency Location/Instance	Room 327 (96 Seats) Seats A/7, 12, B/7, 12, F/7, 12, G/7, 10, 12
Deficiency Quantity	9
Quantity Uom	EACH
Potential Action	REPLACE
Urgency of Action	PRIORITY 5
Purpose of Action	LEVEL 6
Deficiency Photo1	
Violations	Room 327 (96 Seats) Seat A/7 No violations recorded.
GYMNASIUM	Inspected
Instance on 1st Floor - Gymnasium 1	Inspected
Instance on 1st Floor - Gymnasium 2	Inspected
Instance on 1st Floor - Gymnasium 3	Inspected
Ceiling	Inspected
Instance on 1st Floor - Gymnasium 3	Inspected
Condition	2 - Between Good and Fair
Deficiency	PLASTER: CRACKS/SPALLING
Deficiency Location/Instance	Storage Room
Deficiency Quantity	20
Quantity Uom	S.F.
Potential Action	REPLACE

NYC Department of Education
Building Condition Assessment Survey 2023 - 2024

Architectural Inspection

K415

Question	Response
----------	----------

INTERIOR

GYMNASIUM

Ceiling

Urgency of Action
 Purpose of Action
 Deficiency Photo1

PRIORITY 3
 LEVEL 2



Storage Room

Violations

No violations recorded.

Door(s)

Instance on 1st Floor - Gymnasium 1

Inspected

Condition

4 - Between Fair and Poor

Deficiency

WOOD: DETERIORATED DOOR

Deficiency Location/Instance

Main Entrance

Deficiency Quantity

2

Quantity Uom

EACH

Potential Action

MAINTENANCE

Urgency of Action

PRIORITY 3

Purpose of Action

LEVEL 2

Deficiency Photo1



Main Entrance

Violations

No violations recorded.

Instance on 1st Floor - Gymnasium 2

Inspected

Condition

4 - Between Fair and Poor

Deficiency

WOOD: DETERIORATED DOOR

Deficiency Location/Instance

Main Entrance

Deficiency Quantity

2

Quantity Uom

EACH

Potential Action

MAINTENANCE

Urgency of Action

PRIORITY 3

Purpose of Action

LEVEL 2

**NYC Department of Education
Building Condition Assessment Survey 2023 - 2024**

Architectural Inspection

K415

Question	Response
----------	----------

INTERIOR

GYMNASIUM

Door(s)

Deficiency Photo1

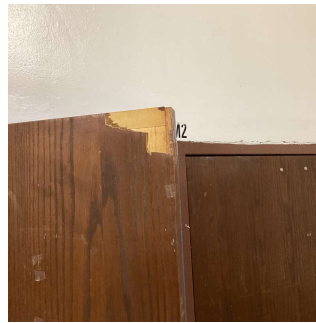

Main Entrance

Violations

No violations recorded.

Instance on 1st Floor - Gymnasium 3

Inspected

Condition

5 - Poor

Deficiency

METAL: DETERIORATED DOOR

Deficiency Location/Instance

Storage Room

Deficiency Quantity

1

Quantity Uom

EACH

Potential Action

MAINTENANCE

Urgency of Action

PRIORITY 3

Purpose of Action

LEVEL 2

Deficiency Photo1



Storage Room

Violations

No violations recorded.

Deficiency

WOOD: DETERIORATED DOOR AND FRAME

Deficiency Location/Instance

2nd Floor Entrance

Deficiency Quantity

2

Quantity Uom

EACH

Potential Action

MAINTENANCE

Urgency of Action

PRIORITY 3

Purpose of Action

LEVEL 2

Deficiency Photo1

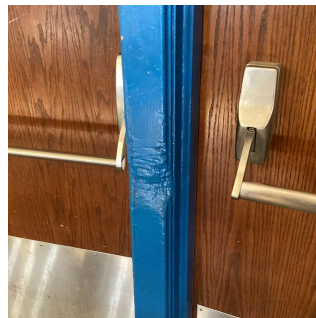

**NYC Department of Education
Building Condition Assessment Survey 2023 - 2024**

Architectural Inspection

K415

Question	Response
INTERIOR	
GYMNASIUM	
Door(s)	
Violations	2nd Floor Entrance No violations recorded.
Fixed Equipment	
Instance on 1st Floor - Gymnasium 2	Inspected
Condition	2 - Between Good and Fair
Deficiency	No deficiencies recorded
Instance on 1st Floor - Gymnasium 3	Inspected
Condition	2 - Between Good and Fair
Deficiency	No deficiencies recorded
Instance on 1st Floor - Gymnasium 1	Inspected
Condition	2 - Between Good and Fair
Deficiency	No deficiencies recorded
Floor Finish	
Instance on 1st Floor - Gymnasium 1	Inspected
Condition	2 - Between Good and Fair
Deficiency	WOOD: DAMAGED/DETERIORATED
Deficiency Location/Instance	Rear Near Windows
Deficiency Quantity	20
Quantity Uom	S.F.
Potential Action	REPLACE
Urgency of Action	PRIORITY 3
Purpose of Action	LEVEL 2
Deficiency Photo1	
Violations	Rear Near Windows No violations recorded.
Instance on 1st Floor - Gymnasium 2	Inspected
Condition	2 - Between Good and Fair
Deficiency	WOOD: DAMAGED/DETERIORATED
Deficiency Location/Instance	Center
Deficiency Quantity	20
Quantity Uom	S.F.
Potential Action	REPLACE
Urgency of Action	PRIORITY 3
Purpose of Action	LEVEL 2

**NYC Department of Education
Building Condition Assessment Survey 2023 - 2024**

Architectural Inspection

K415

Question	Response
-----------------	-----------------

INTERIOR

GYMNASIUM

Floor Finish

Deficiency Photo1



Center

Violations

No violations recorded.

Instance on 1st Floor - Gymnasium 3

Inspected

Condition

5 - Poor

Deficiency

SHEET VINYL: BROKEN/DETERIORATED

Deficiency Location/Instance

2nd Floor Running Track

Deficiency Quantity

500

Quantity Uom

S.F.

Potential Action

REPLACE

Urgency of Action

PRIORITY 3

Purpose of Action

LEVEL 2

Deficiency Photo1

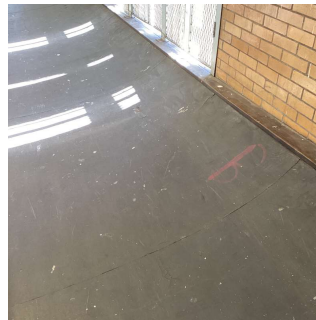

2nd Floor Running Track

Violations

No violations recorded.

Deficiency

WOOD: DAMAGED/DETERIORATED

Deficiency Location/Instance

2nd Floor Running Track, Near Storage Room, Near Exit A

Deficiency Quantity

80

Quantity Uom

S.F.

Potential Action

REPLACE

Urgency of Action

PRIORITY 3

Purpose of Action

LEVEL 2



Deficiency Photo1



**NYC Department of Education
Building Condition Assessment Survey 2023 - 2024**

Architectural Inspection

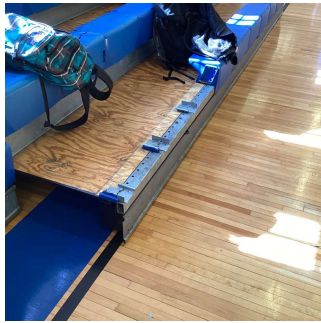
K415

Question	Response
INTERIOR	
GYMNASIUM	
Floor Finish	
Violations	2nd Floor Running Track No violations recorded.
Seating	
Instance on 1st Floor - Gymnasium 3	Inspected
Condition	3 - Fair
Deficiency	DAMAGED FIXED SEATING
Deficiency Location/Instance	Middle Bleachers
Deficiency Quantity	20
Quantity Uom	EACH
Potential Action	REPLACE
Urgency of Action	PRIORITY 5
Purpose of Action	LEVEL 6
Deficiency Photo1	
Violations	Middle Bleachers No violations recorded.
Deficiency	DAMAGED BLEACHERS
Deficiency Location/Instance	Left and Right Side, Center
Deficiency Quantity	80
Quantity Uom	S.F.
Potential Action	REPLACE
Urgency of Action	PRIORITY 3
Purpose of Action	LEVEL 2
Deficiency Photo1	
Violations	Left Side No violations recorded.
Sliding-folding Partition	
Instance on 1st Floor - Gymnasium 2	Does not Exist
Instance on 1st Floor - Gymnasium 3	Does not Exist
Instance on 1st Floor - Gymnasium 1	Does not Exist
Stage	

NYC Department of Education
Building Condition Assessment Survey 2023 - 2024

Architectural Inspection

K415

Question	Response
INTERIOR	
GYMNASIUM	
Stage	
Instance on 1st Floor - Gymnasium 1	Does not Exist
Instance on 1st Floor - Gymnasium 2	Does not Exist
Instance on 1st Floor - Gymnasium 3	Does not Exist
Walls	
Instance on 1st Floor - Gymnasium 3	Inspected
Condition	2 - Between Good and Fair
Deficiency	PLASTER: CRACKS/SPALLING
Deficiency Location/Instance	Storage Room
Deficiency Quantity	20
Quantity Uom	S.F.
Potential Action	REPLACE
Urgency of Action	PRIORITY 3
Purpose of Action	LEVEL 2
Deficiency Photo1	
Violations	Storage Room No violations recorded.
Window Curtains/Shades/Blinds	
Instance on 1st Floor - Gymnasium 2	Does not Exist
Instance on 1st Floor - Gymnasium 3	Does not Exist
Instance on 1st Floor - Gymnasium 1	Does not Exist
INTERIOR DOOR HARDWARE	
Condition	Inspected
Deficiency	3 - Fair
Deficiency	No deficiencies recorded
INTERIOR GUARDS	
Condition	Inspected
Condition	4 - Between Fair and Poor
Deficiency	DETERIORATED/TORN-OUT/MISSING
Deficiency Location/Instance	Stairs B/Basement, 1, 2, GH/1, 3, and others
Deficiency Quantity	300
Quantity Uom	S.F.
Potential Action	REPLACE
Urgency of Action	PRIORITY 3
Purpose of Action	LEVEL 2

**NYC Department of Education
Building Condition Assessment Survey 2023 - 2024**

Architectural Inspection

K415

Question	Response
INTERIOR	
INTERIOR GUARDS	
Deficiency Photo1	
Violations	Stair GH/3 No violations recorded.
KITCHEN	Inspected
Instance on Basement	Inspected
Ceiling	
Instance on Basement	Inspected
Condition	3 - Fair
Deficiency	METAL PAN: DAMAGED/MISSING
Deficiency Location/Instance	Near Sinks area, Near Walk-in Freezer
Deficiency Quantity	20
Quantity Uom	S.F.
Potential Action	REPLACE
Urgency of Action	PRIORITY 5
Purpose of Action	LEVEL 6
Deficiency Photo1	
Violations	Near Sinks area No violations recorded.
Deficiency	METAL PAN: DAMAGED/MISSING
Deficiency Location/Instance	Serving area, near Office
Deficiency Quantity	20
Quantity Uom	S.F.
Potential Action	REPLACE
Urgency of Action	PRIORITY 3
Purpose of Action	LEVEL 2

**NYC Department of Education
Building Condition Assessment Survey 2023 - 2024**

Architectural Inspection

K415

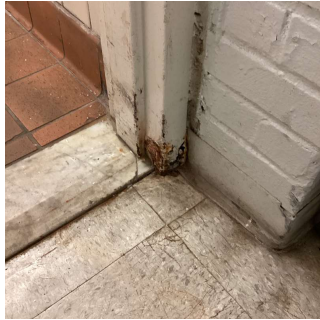
Question	Response
INTERIOR	
KITCHEN	
Ceiling	
Deficiency Photo1	
Violations	Serving area No violations recorded.
Door(s)	
Instance on Basement	Inspected
Condition	5 - Poor
Deficiency	METAL: DETERIORATED DOOR AND FRAME
Deficiency Location/Instance	Storage Room, Near Sinks area
Deficiency Quantity	2
Quantity Uom	EACH
Potential Action	MAINTENANCE
Urgency of Action	PRIORITY 3
Purpose of Action	LEVEL 2
Deficiency Photo1	
Violations	Storage Room No violations recorded.
Deficiency	WOOD: DETERIORATED DOOR
Deficiency Location/Instance	Office
Deficiency Quantity	1
Quantity Uom	EACH
Potential Action	MAINTENANCE
Urgency of Action	PRIORITY 3
Purpose of Action	LEVEL 2

**NYC Department of Education
Building Condition Assessment Survey 2023 - 2024**

Architectural Inspection

K415

Question	Response
----------	----------

INTERIOR

KITCHEN

Door(s)

Deficiency Photo1



Office

No violations recorded.

Violations

Floor Finish

Instance on Basement	Inspected
----------------------	-----------

Condition	3 - Fair
-----------	----------

Deficiency QUARRY TILE: BROKEN/MISSING TILES

Deficiency Location/Instance Serving area

Deficiency Quantity 10

Quantity Uom S.F.

Potential Action REPLACE

Urgency of Action PRIORITY 3

Purpose of Action LEVEL 2

Deficiency Photo1



Serving area

No violations recorded.

Violations

Deficiency QUARRY TILE: DETERIORATED SUBSTRATE

Deficiency Location/Instance Near ovens

Deficiency Quantity 10

Quantity Uom S.F.

Potential Action REPLACE

Urgency of Action PRIORITY 5

Purpose of Action LEVEL 6

**NYC Department of Education
Building Condition Assessment Survey 2023 - 2024**

Architectural Inspection

K415

Question

Response

INTERIOR

KITCHEN

Floor Finish

Deficiency Photo1



Near ovens

Violations

No violations recorded.

Deficiency

VINYL TILES: BROKEN/DETERIORATED/MISSING TILES

Deficiency Location/Instance

Storage Room, Dry Storage Room 1, Dry Storage Room 2,

Deficiency Quantity

50

Quantity Uom

S.F.

Potential Action

REPLACE

Urgency of Action

PRIORITY 3

Purpose of Action

LEVEL 2

Deficiency Photo1

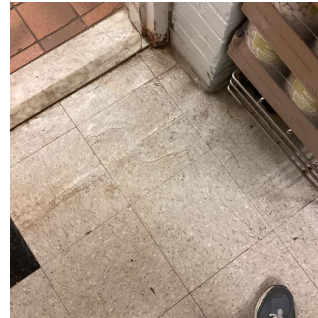

Storage Room

Violations

No violations recorded.

Walls

Instance on Basement

Inspected

Condition

3 - Fair

Deficiency

BRICK: CRACKS/SPALLING

Deficiency Location/Instance

Storage Room

Deficiency Quantity

20

Quantity Uom

S.F.

Potential Action

REPLACE

Urgency of Action

PRIORITY 3

Purpose of Action

LEVEL 2

**NYC Department of Education
Building Condition Assessment Survey 2023 - 2024**

Architectural Inspection

K415

Question

Response

INTERIOR

KITCHEN

Walls

Deficiency Photo1



Storage Room

Violations

No violations recorded.

Deficiency

PLASTER: CRACKS/SPALLING

Deficiency Location/Instance

Office, Dry Storage Room 1

Deficiency Quantity

20

Quantity Uom

S.F.

Potential Action

REPLACE

Urgency of Action

PRIORITY 3

Purpose of Action

LEVEL 2

Deficiency Photo1

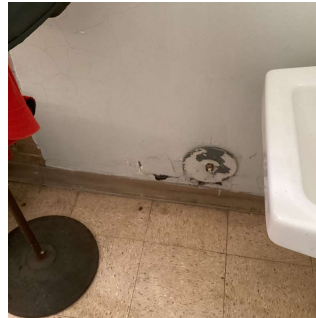

Office

Violations

No violations recorded.

Deficiency

CERAMIC TILE: BROKEN/ MISSING

Deficiency Location/Instance

Serving area, Freezers area, Near Windows, Near Sinks area

Deficiency Quantity

40

Quantity Uom

S.F.

Potential Action

REPLACE

Urgency of Action

PRIORITY 3

Purpose of Action

LEVEL 2

Deficiency Photo1



Serving area

Violations

No violations recorded.

NYC Department of Education
Building Condition Assessment Survey 2023 - 2024

Architectural Inspection

K415

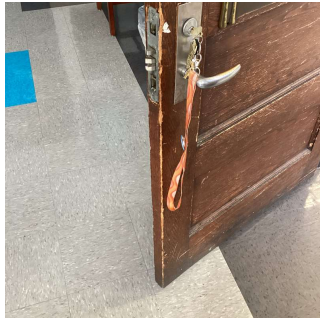
Question	Response
INTERIOR	
LIBRARY	Inspected
Instance on 3rd Floor	Inspected
Built-in Furnishing	
Instance on 3rd Floor	Inspected
Condition	2 - Between Good and Fair
Deficiency	No deficiencies recorded
Ceiling	
Instance on 3rd Floor	Inspected
Condition	2 - Between Good and Fair
Deficiency	No deficiencies recorded
Door(s)	
Instance on 3rd Floor	Inspected
Condition	5 - Poor
Deficiency	WOOD: DETERIORATED DOOR
Deficiency Location/Instance	Rooms 306B, 306C, Main Entrance
Deficiency Quantity	4
Quantity Uom	EACH
Potential Action	MAINTENANCE
Urgency of Action	PRIORITY 3
Purpose of Action	LEVEL 2
Deficiency Photo1	
Room 306B	
Violations	No violations recorded.
Floor Finish	
Instance on 3rd Floor	Inspected
Condition	1 - Good
Deficiency	No deficiencies recorded
Walls	
Instance on 3rd Floor	Inspected
Condition	2 - Between Good and Fair
Deficiency	No deficiencies recorded
LOCKER ROOM	Inspected
Instance on Basement - Boys (1094 Lockers)	Inaccessible
Instance on Basement - Girls (978 Lockers)	Inaccessible
MULTI-PURPOSE ROOM	Does not Exist
SCIENCE DEMO ROOM	Inspected
Instance on Rooms 341, 339, 141	Inspected
Alternative use	No
Instance on Rooms 329, 238, 139, 138	Inspected
Alternative use	Yes
Fixed Equipment	

**NYC Department of Education
Building Condition Assessment Survey 2023 - 2024**

Architectural Inspection

K415

Question	Response
INTERIOR	
SCIENCE DEMO ROOM	
Fixed Equipment	
Instance on Rooms 341, 339, 141	Inspected
Condition	2 - Between Good and Fair
Deficiency	No deficiencies recorded
Instance on Rooms 329, 238, 139, 138	Inspected
Condition	2 - Between Good and Fair
Deficiency	No deficiencies recorded
SCIENCE LAB	
Instance on Rooms 340, 241, 240, 140	Inspected
Alternative use	No
Fixed Equipment	
Instance on Rooms 340, 241, 240, 140	Inspected
Condition	2 - Between Good and Fair
Deficiency	No deficiencies recorded
SCIENCE PREP ROOM	
Instance on Rooms 340A, 240A, 239, 140A	Inspected
Alternative use	No
Fixed Equipment	
Instance on Rooms 340A, 240A, 239, 140A	Inspected
Condition	2 - Between Good and Fair
Deficiency	No deficiencies recorded
SHOWER ROOM	
Instance on Basement - Boys	Inaccessible
Instance on Basement - Girls	Inaccessible
STAIRS/RAMPS: INTERIOR	
Do Letter Stair Signs Exist?	Yes
Ceiling	
Condition	2 - Between Good and Fair
Deficiency	PLASTER: CRACKS/SPALLING
Deficiency Location/Instance	Stairs A/Basement, 2, B/2, C/2, F/3 and other
Deficiency Quantity	120
Quantity Uom	S.F.
Potential Action	REPLACE
Urgency of Action	PRIORITY 3
Purpose of Action	LEVEL 2
Deficiency Photo1	
Violations	Stair F/3 No violations recorded.
Door(s)	
Condition	5 - Poor

**NYC Department of Education
Building Condition Assessment Survey 2023 - 2024**

Architectural Inspection

K415

Question	Response
INTERIOR	
STAIRS/RAMPS: INTERIOR	
Door(s)	
Deficiency	METAL: DETERIORATED DOOR AND FRAME
Deficiency Location/Instance	Stair GH/1 Vestibule
Deficiency Quantity	4
Quantity Uom	EACH
Potential Action	MAINTENANCE
Urgency of Action	PRIORITY 3
Purpose of Action	LEVEL 2
Deficiency Photo1	
Violations	Stair GH/1 Vestibule No violations recorded.
Deficiency	WOOD: DETERIORATED DOOR
Deficiency Location/Instance	Stairs F/Basement Vestibule, L/1, Basement Vestibule
Deficiency Quantity	6
Quantity Uom	EACH
Potential Action	MAINTENANCE
Urgency of Action	PRIORITY 3
Purpose of Action	LEVEL 2
Deficiency Photo1	
Violations	Stair L/1 No violations recorded.
Partition	Inspected
Condition	3 - Fair
Deficiency	METAL FRAME: DAMAGED/DETERIORATED
Deficiency Location/Instance	Stairs A/Basement, 1, 2, B/Basement, J/1 and others
Deficiency Quantity	80
Quantity Uom	L.F.
Potential Action	REPLACE
Urgency of Action	PRIORITY 3
Purpose of Action	LEVEL 2

**NYC Department of Education
Building Condition Assessment Survey 2023 - 2024**

Architectural Inspection

K415

Question	Response
----------	----------

INTERIOR

STAIRS/RAMPS: INTERIOR

Partition

Deficiency Photo1



Stair J/1

Violations

No violations recorded.

Railings

Inspected

Condition

4 - Between Fair and Poor

Deficiency

METAL: MISSING

Deficiency Location/Instance

Stairs B/Basement, C/1 Vestibule

Deficiency Quantity

20

Quantity Uom

L.F.

Potential Action

REPLACE

Urgency of Action

PRIORITY 5

Purpose of Action

LEVEL 6

Deficiency Photo1



Stair B/Basement

Violations

No violations recorded.

Stairs and Landings

Inspected

Condition

3 - Fair

Deficiency

STONE: WORN-OUT TREAD/NOSINGS

Deficiency Location/Instance

Stair K/1

Deficiency Quantity

120

Quantity Uom

S.F.

Potential Action

REPLACE

Urgency of Action

PRIORITY 3

Purpose of Action

LEVEL 2

**NYC Department of Education
Building Condition Assessment Survey 2023 - 2024**

Architectural Inspection

K415

Question

Response

INTERIOR

STAIRS/RAMPS: INTERIOR

Stairs and Landings

Deficiency Photo1

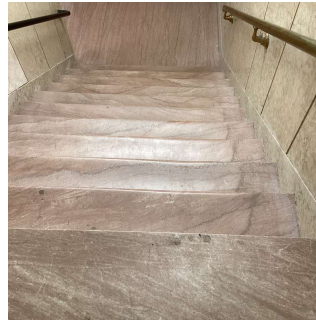

Stair K/1

No violations recorded.

Violations

Deficiency

STONE: BROKEN/MISSING

Deficiency Location/Instance

Exit 11 Vestibule

Deficiency Quantity

20

Quantity Uom

S.F.

Potential Action

REPLACE

Urgency of Action

PRIORITY 3

Purpose of Action

LEVEL 2

Deficiency Photo1

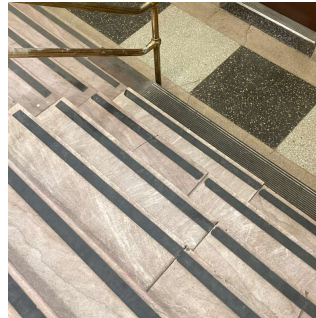

Exit 11 Vestibule

No violations recorded.

Violations

Deficiency

TERRAZZO: CRACKS

Deficiency Location/Instance

Stair C/1 Vestibule

Deficiency Quantity

20

Quantity Uom

S.F.

Potential Action

REPLACE

Urgency of Action

PRIORITY 3

Purpose of Action

LEVEL 2

Deficiency Photo1



Stair C/1 Vestibule

No violations recorded.

Violations

**NYC Department of Education
Building Condition Assessment Survey 2023 - 2024**

Architectural Inspection

K415

Question	Response
INTERIOR	
STAIRS/RAMPS: INTERIOR	
Stairs and Landings	
Deficiency	CONCRETE: CRACKS/SPALLING - MAJOR
Deficiency Location/Instance	Stair DE/1
Deficiency Quantity	10
Quantity Uom	S.F.
Potential Action	REPLACE
Urgency of Action	PRIORITY 5
Purpose of Action	LEVEL 6
Deficiency Photo1	
Violations	Stair DE/1 No violations recorded.
Deficiency	METAL: RUST - MAJOR
Deficiency Location/Instance	Stair A/Basement
Deficiency Quantity	10
Quantity Uom	S.F.
Potential Action	REPLACE
Urgency of Action	PRIORITY 3
Purpose of Action	LEVEL 2
Deficiency Photo1	
Violations	Stair A/Basement No violations recorded.
Deficiency	CONCRETE: CRACKS/SPALLING - MAJOR
Deficiency Location/Instance	Stairs GH/Basement, J/3, L/1,
Deficiency Quantity	75
Quantity Uom	S.F.
Potential Action	REPLACE
Urgency of Action	PRIORITY 3
Purpose of Action	LEVEL 2

**NYC Department of Education
Building Condition Assessment Survey 2023 - 2024**

Architectural Inspection

K415

Question	Response
----------	----------

INTERIOR

STAIRS/RAMPS: INTERIOR

Stairs and Landings

Deficiency Photo1



Stair J/3

Violations

No violations recorded.

Walls

Inspected

Condition

2 - Between Good and Fair

Deficiency

STONE: CRACKS/SPALLING

Deficiency Location/Instance

Stair C/1 Vestibule

Deficiency Quantity

20

Quantity Uom

S.F.

Potential Action

REPLACE

Urgency of Action

PRIORITY 3

Purpose of Action

LEVEL 2

Deficiency Photo1



Stair C/1 Vestibule

Violations

No violations recorded.

Deficiency

PLASTER: CRACKS/SPALLING

Deficiency Location/Instance

Stairs A/1, 3, B/1, 2, M/Basement, and others

Deficiency Quantity

550

Quantity Uom

S.F.

Potential Action

REPLACE

Urgency of Action

PRIORITY 3

Purpose of Action

LEVEL 2

Deficiency Photo1



**NYC Department of Education
Building Condition Assessment Survey 2023 - 2024**

Architectural Inspection

K415

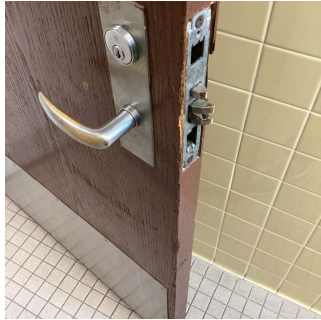
Question	Response
INTERIOR	
STAIRS/RAMPS: INTERIOR	Inspected
Walls	Inspected
Violations	Stair M/Basement No violations recorded.
TOILET ROOMS - STAFF	Inspected
Ceiling	Inspected
Condition	2 - Between Good and Fair
Deficiency	No deficiencies recorded
Door(s)	Inspected
Condition	5 - Poor
Deficiency	WOOD: DETERIORATED DOOR
Deficiency Location/Instance	Rooms 345A, 220A
Deficiency Quantity	2
Quantity Uom	EACH
Potential Action	MAINTENANCE
Urgency of Action	PRIORITY 3
Purpose of Action	LEVEL 2
Deficiency Photo1	
Violations	Room 345A No violations recorded.
Floor Finish	Inspected
Condition	2 - Between Good and Fair
Deficiency	No deficiencies recorded
Stalls	Inspected
Condition	2 - Between Good and Fair
Deficiency	No deficiencies recorded
Walls	Inspected
Condition	2 - Between Good and Fair
Deficiency	No deficiencies recorded
TOILET ROOMS - STUDENTS	Inspected
Ceiling	Inspected
Condition	2 - Between Good and Fair
Deficiency	PLASTER: CRACKS/SPALLING
Deficiency Location/Instance	Room 244A
Deficiency Quantity	20
Quantity Uom	S.F.
Potential Action	REPLACE
Urgency of Action	PRIORITY 3
Purpose of Action	LEVEL 2

**NYC Department of Education
Building Condition Assessment Survey 2023 - 2024**

Architectural Inspection

K415

Question	Response
INTERIOR	
TOILET ROOMS - STUDENTS	
Ceiling	
Deficiency Photo1	
Violations	Room 244A No violations recorded.
Door(s)	Inspected
Condition	5 - Poor
Deficiency	WOOD: DETERIORATED DOOR
Deficiency Location/Instance	Rooms 318B, 318A, 245A, 244A, 107A and others
Deficiency Quantity	6
Quantity Uom	EACH
Potential Action	MAINTENANCE
Urgency of Action	PRIORITY 3
Purpose of Action	LEVEL 2
Deficiency Photo1	
Violations	Room 318B No violations recorded.
Floor Finish	Inspected
Condition	2 - Between Good and Fair
Deficiency	CERAMIC TILE: DETERIORATED SUBSTRATE
Deficiency Location/Instance	Rooms 318A, 318B, 245, 244A
Deficiency Quantity	40
Quantity Uom	S.F.
Potential Action	REPLACE
Urgency of Action	PRIORITY 3
Purpose of Action	LEVEL 2

**NYC Department of Education
Building Condition Assessment Survey 2023 - 2024**

Architectural Inspection

K415

Question	Response
----------	----------

INTERIOR

TOILET ROOMS - STUDENTS

Floor Finish

Deficiency Photo1



Room 318B

Violations

No violations recorded.

Stalls

Inspected

Condition

5 - Poor

Deficiency

RUST - MAJOR

Deficiency Location/Instance

Room 107A

Deficiency Quantity

4

Quantity Uom

EACH

Potential Action

REPLACE

Urgency of Action

PRIORITY 3

Purpose of Action

LEVEL 2

Deficiency Photo1

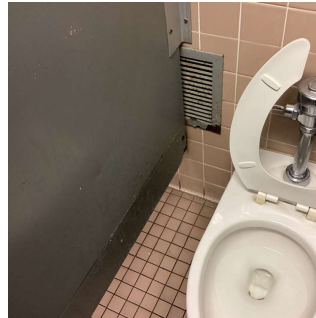

Room 107A

Violations

No violations recorded.

Walls

Inspected

Condition

2 - Between Good and Fair

Deficiency

PLASTER: CRACKS/SPALLING

Deficiency Location/Instance

Room 318B

Deficiency Quantity

10

Quantity Uom

S.F.

Potential Action

REPLACE

Urgency of Action

PRIORITY 3

Purpose of Action

LEVEL 2

**NYC Department of Education
Building Condition Assessment Survey 2023 - 2024**

Architectural Inspection

K415

Question	Response
INTERIOR	
TOILET ROOMS - STUDENTS	
Walls	
Deficiency Photo1	
Violations	Room 318B No violations recorded.
Deficiency	CERAMIC TILE: BROKEN/ MISSING
Deficiency Location/Instance	Rooms 318B, 244A, 245A, 107A
Deficiency Quantity	40
Quantity Uom	S.F.
Potential Action	REPLACE
Urgency of Action	PRIORITY 3
Purpose of Action	LEVEL 2
Deficiency Photo1	
Violations	Room 318B No violations recorded.
LIFE SAFETY	Inspected
F.D. HOLDING AREA	Does not Exist
STEEL STAIRS	Does not Exist
SITE	Inspected
CONTAINERIZATION	Inspected
Condition	5 - Poor
Deficiency	FENCING MISSING
Deficiency Location/Instance	Near Athletic Field
Deficiency Quantity	600
Quantity Uom	S.F.
Potential Action	INSTALL NEW
Urgency of Action	PRIORITY 3
Purpose of Action	LEVEL 2
Deficiency Photo1	No photo recorded
Violations	No violations recorded.
Deficiency	CONTAINER DAMAGED
Deficiency Location/Instance	Near Athletic Field

NYC Department of Education
Building Condition Assessment Survey 2023 - 2024

Architectural Inspection

K415

Question	Response
SITE	
CONTAINERIZATION	
Deficiency Quantity	3
Quantity Uom	EACH
Potential Action	REPLACE
Urgency of Action	PRIORITY 3
Purpose of Action	LEVEL 2
Deficiency Photo1	
Violations	Near Athletic Field No violations recorded.
Drainage System for Asphalt	Does not Exist
Drainage System for Concrete	Inspected
Catch Basins/Manhole - Surrounded by concrete	Inspected
Condition	5 - Poor
Deficiency	BLOCKED
Deficiency Location/Instance	Near Athletic Field
Deficiency Quantity	2
Quantity Uom	EACH
Potential Action	MAINTENANCE
Urgency of Action	PRIORITY 3
Purpose of Action	LEVEL 2
Deficiency Photo1	No photo recorded
Violations	No violations recorded.
Culverts - Concrete Covering	Does not Exist
Drainage System for Soil	Inspected
Catch Basins/Manhole - Surrounded by Soil	Inspected
Condition	2 - Between Good and Fair
Deficiency	No deficiencies recorded
Culverts - Soil Covering	Does not Exist
DRINKING FOUNTAINS	Does not Exist
FENCES	Inspected
Condition	4 - Between Fair and Poor
Deficiency	WROUGHT IRON: DAMAGED/DETERIORATED
Deficiency Location/Instance	Near Exit 9
Deficiency Quantity	40
Quantity Uom	S.F.
Potential Action	REPLACE
Urgency of Action	PRIORITY 5
Purpose of Action	LEVEL 6

**NYC Department of Education
Building Condition Assessment Survey 2023 - 2024**

Architectural Inspection

K415

Question

Response

SITE

FENCES

Deficiency Photo1



Near Exit 9

Violations

No violations recorded.

Deficiency

CONCRETE CURB: DAMAGED/DETERIORATED

Deficiency Location/Instance

Tilden Avenue, East 59th Street, East 57th Street, near Athletic Field

Deficiency Quantity

120

Quantity Uom

S.F.

Potential Action

REPLACE

Urgency of Action

PRIORITY 3

Purpose of Action

LEVEL 2

Deficiency Photo1

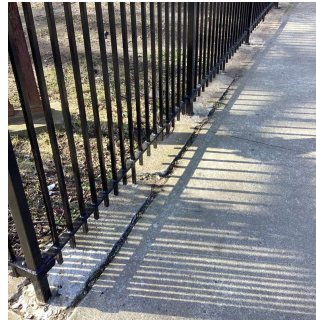

Tilden Avenue

Violations

No violations recorded.

Deficiency

WROUGHT IRON: DAMAGED/DETERIORATED

Deficiency Location/Instance

Tilden Avenue, East 59th Street, East 57th Street, near Athletic Field

Deficiency Quantity

1,120

Quantity Uom

S.F.

Potential Action

REPLACE

Urgency of Action

PRIORITY 3

Purpose of Action

LEVEL 2

Deficiency Photo1



East 59th Street

Violations

No violations recorded.

IRRIGATION SYSTEM

Does not Exist

**NYC Department of Education
Building Condition Assessment Survey 2023 - 2024**

Architectural Inspection



K415

Question	Response
SITE	
IRRIGATION SYSTEM	Does not Exist
PAVING	Inspected
Student Non-Use	Inspected
Gravel Exists?	No
Asphalt	Does not Exist
Concrete	Inspected
Condition	4 - Between Fair and Poor
Deficiency	CRACKS - MAJOR
Deficiency Location/Instance	Driveway near Athletic Field, parking lot, East 57th Street
Deficiency Quantity	600
Quantity Uom	S.F.
Potential Action	REPLACE
Urgency of Action	PRIORITY 3
Purpose of Action	LEVEL 2
Deficiency Photo1	
	Driveway near Athletic Field
Violations	No violations recorded.
Pavers	Does not Exist
Student Use	Does not Exist
Site Sidewalks & Walkways	Inspected
Asphalt	Does not Exist
Concrete	Inspected
Condition	3 - Fair
Deficiency	CRACKS - MAJOR
Deficiency Location/Instance	Near Exit 6, near Athletic Field
Deficiency Quantity	275
Quantity Uom	S.F.
Potential Action	REPLACE
Urgency of Action	PRIORITY 3
Purpose of Action	LEVEL 2
Deficiency Photo1	
	Near Exit 6

**NYC Department of Education
Building Condition Assessment Survey 2023 - 2024**

Architectural Inspection

K415

Question	Response
SITE	
PAVING	Inspected
Site Sidewalks & Walkways	Inspected
Concrete	Inspected
Violations	No violations recorded.
Pavers	Does not Exist
DOT Sidewalk	Inspected
Asphalt	Does not Exist
Concrete	Inspected
Condition	4 - Between Fair and Poor
Deficiency	DAMAGED CURBS
Deficiency Location/Instance	Tilden Avenue, East 59th Street, East 57th Street
Deficiency Quantity	160
Quantity Uom	L.F.
Potential Action	REPLACE
Urgency of Action	PRIORITY 3
Purpose of Action	LEVEL 2
Deficiency Photo1	
Violations	Tilden Avenue No violations recorded.
Deficiency	DAMAGED/DETERIORATED/MISSING SECTIONS
Deficiency Location/Instance	Tilden Avenue, East 59th Street, East 57th Street
Deficiency Quantity	1,625
Quantity Uom	S.F.
Potential Action	REPLACE
Urgency of Action	PRIORITY 3
Purpose of Action	LEVEL 2
Deficiency Photo1	
Violations	Tilden Avenue No violations recorded.
Deficiency	DAMAGED/DETERIORATED/MISSING SECTIONS
Deficiency Location/Instance	Tilden Avenue
Deficiency Quantity	50

NYC Department of Education
Building Condition Assessment Survey 2023 - 2024

Architectural Inspection

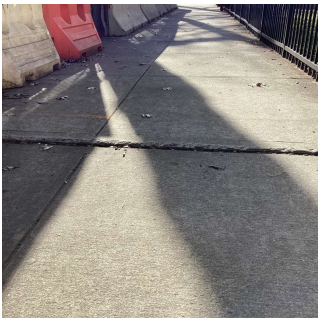

K415

Question	Response
SITE	
PAVING	
DOT Sidewalk	Inspected
Concrete	Inspected
Quantity Uom	S.F.
Potential Action	REPLACE
Urgency of Action	PRIORITY 5
Purpose of Action	LEVEL 6
Deficiency Photo1	
Violations	Tilden Avenue No violations recorded.
Deficiency	HEAVING
Deficiency Location/Instance	Tilden Avenue, East 59th Street, East 57th Street
Deficiency Quantity	400
Quantity Uom	S.F.
Potential Action	REPLACE
Urgency of Action	PRIORITY 3
Purpose of Action	LEVEL 2
Deficiency Photo1	
Violations	East 59th Street No violations recorded.
Pavers	Does not Exist
PLAYGROUNDS	Does not Exist
PLAYING SURFACE	Does not Exist
RETAINING WALLS	Inspected
Are there any Retaining Walls 6' OR higher facing public street/sidewalk?	No
Condition	3 - Fair
Deficiency	CAST IN PLACE CONCRETE: CRACKS/SPALLING - MAJOR
Deficiency Location/Instance	Near Exit 6
Deficiency Quantity	20
Quantity Uom	S.F.
Potential Action	REPLACE
Urgency of Action	PRIORITY 3

**NYC Department of Education
Building Condition Assessment Survey 2023 - 2024**

Architectural Inspection



K415

Question	Response
SITE	
RETAINING WALLS	
Purpose of Action	LEVEL 2
Deficiency Photo1	
Violations	Near Exit 6 No violations recorded.
Deficiency	MASONRY UNIT: DETERIORATED CONTROL/EXPANSION JOINT
Deficiency Location/Instance	Near Exit 6
Deficiency Quantity	20
Quantity Uom	L.F.
Potential Action	REPLACE
Urgency of Action	PRIORITY 3
Purpose of Action	LEVEL 2
Deficiency Photo1	
Violations	Near Exit 6 No violations recorded.
SEATING	Does not Exist
SITE WALLS (NOT RETAINING WALLS)	Does not Exist
STAIRS/RAMPS: EXTERIOR	Does not Exist
ARTWORK	Inspected
Instance	Interior - Room 327 - 21027
Instance ID	21027
Artwork exist at stated location?	No
Instance	Interior - Room 327 - 17015
Instance Photo	
	Room 327
Instance ID	17015
Artwork exist at stated location?	Yes

**NYC Department of Education
Building Condition Assessment Survey 2023 - 2024**

Architectural Inspection

K415

Question	Response
ARTWORK	
Instance	Interior - Room 327 - 17014
Instance Photo	
Instance ID	Room 327
Artwork exist at stated location?	17014 Yes
Instance	Interior - Auditorium - 21063
Instance Photo	
Instance ID	Auditorium
Artwork exist at stated location?	21063 Yes