

NYC Department of Education
Building Condition Assessment Survey 2023 - 2024

Architectural Inspection

K237

Asset: LUCRETIA MARCIGLIANO CAMPUS - K, 50 AVENUE P, New York, 11204

Inspection Id	Inspection Type	Time In	Last Edited
SA : K237	Architectural - Senior	2023-10-20 7:47 AM	2024-06-16 11:39 AM
AA : K237	Architectural - Associate	2023-10-20 7:15 AM	2023-10-31 9:54 AM

Asset Data

Question	Answer
Was the building fully accessible for inspection	No
Inspection Access Comment	Basement Girls Locker Room Basement Boys Locker Room (Storage)
Building Square Footage	94,000
Comments on the Area (for Athletic Field, Playing Surfaces, Leased Spaces)	None
Comments on the Stories (Floors) plus Basements	4+B
Comments on the Number of Classrooms	50
Comments on the Year Built	2009
Student Population	917
Staff Population	170
Weather	Fair
Principal(s) Information	
Principal Name	Eric Havlik
Organization	P.S./I.S. 686 - Brooklyn School of Inquiry - Brooklyn
Did you meet with this Principal?	Yes
Did this Principal provide feedback?	Yes
Summary of Principal's Feedback	The Principal's comments are as follows: 1. The HVAC system needs to be balanced. 2. The cracked window panes in Room 407 and 414 (Main Office) need replacement. 3. Drinking Fountains in 4th Floor Corridor have very low water pressure, and need to be readjusted.
Principal Name	Josephine Sportella
Organization	P.S. 682 - The Academy of Talented Scholars - Brooklyn
Did you meet with this Principal?	No
Did this Principal provide feedback?	No
Principal Name	Susan Miller
Organization	P.S. 682 - The Academy for Building Learning Experience (District 75) - Brooklyn
Did you meet with this Principal?	No
Did this Principal provide feedback?	No
Custodian	Was not present
Fireman	James Mulroy

Facade Photo



Corner of Avenue P and Stillwell Avenue - Southeast view

Main Entrance Photo



Facade A - Avenue P

Roof Photo



Roof 1 - North view

NYC Department of Education
Building Condition Assessment Survey 2023 - 2024

Architectural Inspection

K237

Have any Systems/Major Building Components been upgraded?	Yes
	Systems: Green House; Partial Roofing repairs
	Year: 2023
Have there been any Building Additions?	No
Tandem Schools?	No
Leased Space?	No

Priority Condition

Priority Condition Exist Last Year?	Priority Category	Condition Description	Component Affected	Location Description	Person(s) Notified	Person(s) Title	PhotoImage
Yes	Tripping Hazard	Severely damaged Wood Floor is a potential tripping hazard	INTERIOR GYMNASIUM Floor Finish	Near Sliding Folding Partition	James Mulroy	Fireman	

Structural Engineer Required

Structural Condition Type	Condition Description	Component Affected	Location Description	Person(s) Notified	Person(s) Title	PhotoImage
No condition recorded						

Programmatic Accessibility

Programmatic Accessibility Status Question	Response
Is the primary or secondary entrance on an accessible route?	Yes
Is the building a multi-story building?	Yes
Are all floors of the building accessible through compliant means?	Yes
Accessible classrooms exists on each floor?	Yes
Boys and Girls or Unisex accessible toilets exist on at least every other floor?	Yes
If the following spaces exist, are they ALL accessible? Art Room, Auditorium, Cafeteria, Computer, Gymnasiums, Library, Multipurpose Room, Science Labs	Yes

Physical Breakdown Structure	Exists	Required	Complies	Deficiency	Assistive Listening System	Fire Alarm Strobe
PROGRAMMATIC ACCESSIBILITY						
Exterior Routes						
Exterior Entrances & Exits			Yes			
Exterior H/C Lifts	No	No				
Exterior Ramps and Railings	Yes		Yes			
Interior Routes						
Corridor and Lobby H/C Lifts	No	No				
Interior Corridor Doors and Hardware	Yes		Yes			
Interior Corridors and Lobbies			Yes			
Interior Elevators	Yes		Yes			
Interior Lobby Doors and Hardware			Yes			
Interior Ramps	No					
Rooms & Spaces						
Art Rooms	Room 309, 326	Yes	Yes			
Auditorium	1st Floor	Yes	Yes		FM System	Yes

NYC Department of Education
Building Condition Assessment Survey 2023 - 2024

Architectural Inspection

K237

Physical Breakdown Structure	Exists	Required	Complies	Deficiency	Assistive Listening System	Fire Alarm Strobe
Rooms & Spaces						
Cafeteria	Basement	Yes		Yes	FM System	Yes
Classrooms	1st-4th Floor	Yes		Yes		
Computer Rooms		No				
Gymnasium	Basement	Yes		Yes	FM System	Yes
Library	Room 314	Yes		Yes		
Main Office	Room 201 (The Academy for Building Learning Experience - District 75); Room 214 (The Academy of Talented Scholars); Room 414 (Brooklyn School of Inquiry)	Yes		Yes		
Multi-purpose Room		No				
Nurse's Room	Rooms C14, 211	Yes		Yes		
Pool		No				
Science Lab	Rooms 320, 409	Yes		Yes		
Toilet Rooms (Boys)	Basement, 1st-4th Floor	Yes		Yes		
Toilet Rooms (Girls)	Basement, 1st-4th Floor	Yes		Yes		
Toilet Rooms (Staff)	Basement, 1st-4th Floor	Yes		Yes		

Building Template

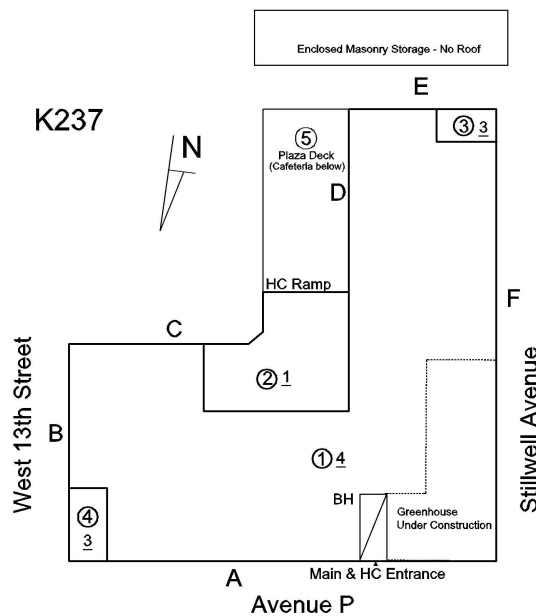

Inspection

Question	Response
Architectural	
EXTERIOR	Inspected
AREAWAY	Does not Exist
AWNINGS AND CANOPIES	Inspected
Condition	3 - Fair
Deficiency	METAL: DETERIORATION/DAMAGED/MISSING PIECES

**NYC Department of Education
Building Condition Assessment Survey 2023 - 2024**

Architectural Inspection

K237

Question	Response
----------	----------

EXTERIOR

AWNINGS AND CANOPIES

Roof Plan reference

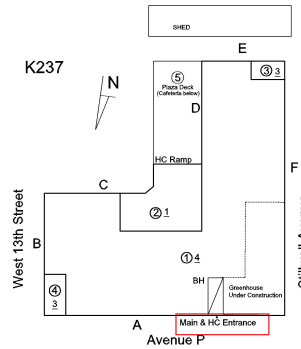

Deficiency Quantity
Quantity Uom
Potential Action
Urgency of Action
Purpose of Action
Deficiency Photo1

20
S.F.
REPLACE
PRIORITY 4
LEVEL 2

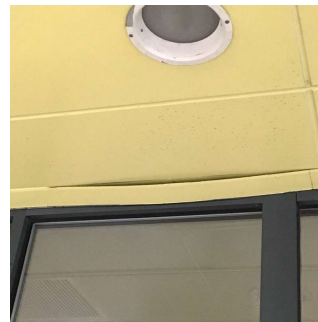

Facade A

Violations

No violations recorded.

CHIMNEY	Does not Exist
----------------	----------------

COPING	Inspected
---------------	-----------

Condition	2 - Between Good and Fair
-----------	---------------------------

Deficiency	No deficiencies recorded
------------	--------------------------

CORNICE	Does not Exist
----------------	----------------

DOORS	Inspected
--------------	-----------

DOORS AND FRAMES	Inspected
-------------------------	-----------

Condition	3 - Fair
-----------	----------

Deficiency	METAL: DETERIORATED DOOR - MAJOR DETERIORATION
------------	--

Roof Plan reference

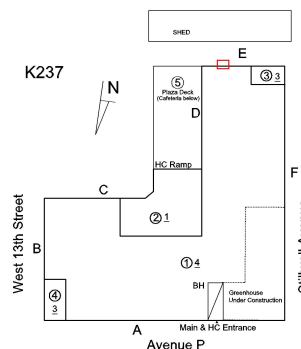

Deficiency Quantity
Quantity Uom
Potential Action

1
EACH
REPLACE

NYC Department of Education
Building Condition Assessment Survey 2023 - 2024

Architectural Inspection

K237

Question	Response
----------	----------

EXTERIOR

DOORS

DOORS AND FRAMES

Urgency of Action

PRIORITY 4

Purpose of Action

LEVEL 2

Deficiency Photo1

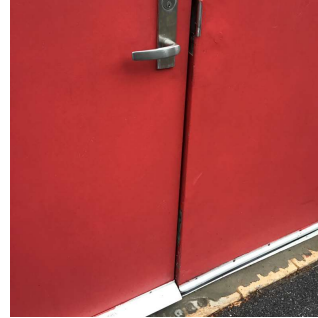

Facade E

Violations

No violations recorded.

DOOR HARDWARE

Inspected

Condition

3 - Fair

Deficiency

No deficiencies recorded

LINTELS

Inspected

Condition

2 - Between Good and Fair

Deficiency

No deficiencies recorded

TRANSOM/SIDE LIGHT

Inspected

Condition

2 - Between Good and Fair

Deficiency

No deficiencies recorded

EXTERIOR WALLS

Inspected

Material Type(s)

Masonry, Steel

Replacement Quantity

15,000

Replacement Uom

S.F.

Instance on All Facades

Inspected

Instance Condition

3 - Fair

Instance Quantity

15,000

Instance Quantity Uom

S.F.

Deficiency

BRICK: CRACKS/DISPLACED/SPALLED BRICK AT BUILDING CORNERS

Roof Plan reference

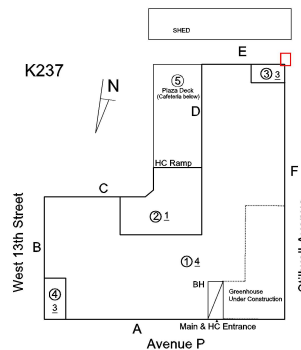

**NYC Department of Education
Building Condition Assessment Survey 2023 - 2024**

Architectural Inspection

K237

Question	Response
EXTERIOR	
EXTERIOR WALLS	
Elevation	
Deficiency Quantity	10
Quantity Uom	S.F.
Potential Action	REMOVE AND REBUILD
Urgency of Action	PRIORITY 4
Purpose of Action	LEVEL 2
Deficiency Photo1	
Violations	Facade E No violations recorded.
EXTERIOR SOFFITS	Inspected
Condition	2 - Between Good and Fair
Deficiency	No deficiencies recorded
LOADING DOCK	Does not Exist
LOUVER	Inspected
Condition	2 - Between Good and Fair
Deficiency	No deficiencies recorded
PARAPETS	Inspected
Material Type(s)	Concrete, Masonry
Replacement Quantity	3,000
Replacement Uom	C.F.
Instance on All Facades	Inspected
Instance Condition	2 - Between Good and Fair
Instance Quantity	3,000
Instance Quantity Uom	C.F.
Deficiency	CONCRETE: MINOR CRACKS, SPALLING

NYC Department of Education
Building Condition Assessment Survey 2023 - 2024

Architectural Inspection

K237

Question	Response
----------	----------

EXTERIOR

PARAPETS

Roof Plan reference

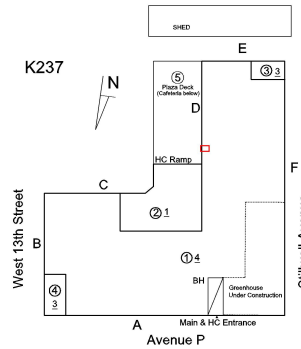

Deficiency Quantity
 Quantity Uom
 Potential Action
 Urgency of Action
 Purpose of Action
 Deficiency Photo1

10
 S.F.
 REPAIR
 PRIORITY 3
 LEVEL 2

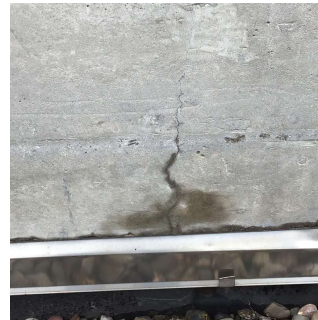

Roof 1
 No violations recorded.

Violations

PLAZA DECK

Instance on Concrete: Roof 5

Instance Condition

Instance Quantity

Instance Quantity Uom

Installation Year

Source of Installation

Deficiency

Inspected
 Inspected
 2 - Between Good and Fair
 3,000
 S.F.
 2009
 Custodial Staff
 No deficiencies recorded

ROOF

Roofing

Replacement Quantity

Replacement Uom

ROOF HATCH/SMOKE HATCH

Condition

Deficiency

LEADERS, GUTTERS, DOWNSPOUTS, SCUPPERS

Condition

Deficiency

ROOF BARRIER/FENCE

Condition

Deficiency

ROOF CAGE

Inspected
 Inspected
 18,000
 S.F.
 Inspected
 2 - Between Good and Fair
 No deficiencies recorded
 Inspected
 2 - Between Good and Fair
 No deficiencies recorded
 Inspected
 2 - Between Good and Fair
 No deficiencies recorded
 Does not Exist

**NYC Department of Education
Building Condition Assessment Survey 2023 - 2024**

Architectural Inspection

K237

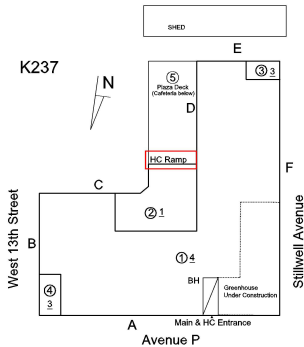
Question	Response
EXTERIOR	
ROOF	
Roofing	
ROOFING	Inspected
Instance on IRMA: Roofs 1-4	Inspected
Instance Condition	2 - Between Good and Fair
Instance Photo	
	Roof 1
Instance Quantity	18,000
Instance Quantity Uom	S.F.
Does the roof have major mechanical equipment sitting on Dunnage Steel less than 18" above the Roofing?	No
Does this roof instance have a Sustainable Roof System?	No
Do solar panels exist on these roofs?	No
Is/Are the roof(s) suitable for Solar Panel installation?	No
Installation Year	2009
Source of Installation	Custodial Staff
Deficiency	No deficiencies recorded
ROOFING DRAINS	Inspected
Condition	2 - Between Good and Fair
Deficiency	No deficiencies recorded
Specialties	Inspected
BULKHEAD/PENTHOUSE	Inspected
Condition	2 - Between Good and Fair
Deficiency	No deficiencies recorded
CUPOLA/ SPIRES/ TOWERS	Does not Exist
DORMER	Does not Exist
DUNNAGE STEEL	Does not Exist
SKYLIGHT/ROOF VENT	Does not Exist
ROOF/GRAVITY TANK	Does not Exist
STAIRS/RAMPS: EXTERIOR	Inspected
BUILDING CHEEK/FLANK WALLS	Inspected
Condition	3 - Fair
Deficiency	CAST IN PLACE CONCRETE: DETERIORATED CONTROL/EXPANSION JOINT
Roof Plan reference	
Deficiency Quantity	10

NYC Department of Education
Building Condition Assessment Survey 2023 - 2024

Architectural Inspection

K237

Question	Response
----------	----------

EXTERIOR

STAIRS/RAMPS: EXTERIOR

BUILDING CHEEK/FLANK WALLS

Quantity Uom
 Potential Action
 Urgency of Action
 Purpose of Action
 Deficiency Photo1

L.F.
 REPLACE
 PRIORITY 3
 LEVEL 2

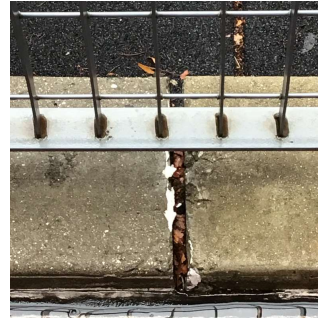

Facade C

No violations recorded.

Violations

Deficiency

Roof Plan reference

CAST IN PLACE CONCRETE: CRACKS/SPALLING - MINOR

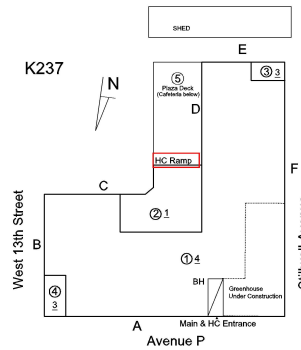

Deficiency Quantity
 Quantity Uom
 Potential Action
 Urgency of Action
 Purpose of Action
 Deficiency Photo1

10
 S.F.
 REPAIR
 PRIORITY 3
 LEVEL 2

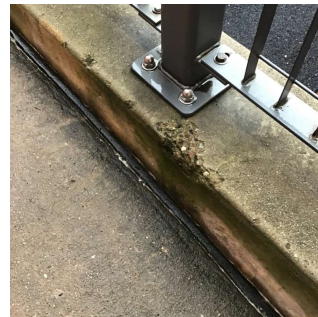

Facade C

No violations recorded.

Violations

RAILINGS

Condition

Deficiency

Inspected
 2 - Between Good and Fair
 No deficiencies recorded

STAIRS/RAMPS

Condition

Inspected
 2 - Between Good and Fair

**NYC Department of Education
Building Condition Assessment Survey 2023 - 2024**

Architectural Inspection

K237

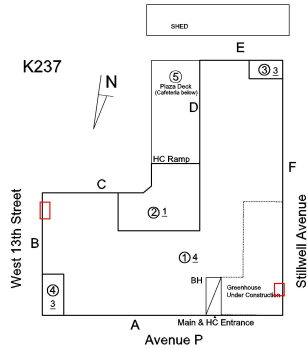
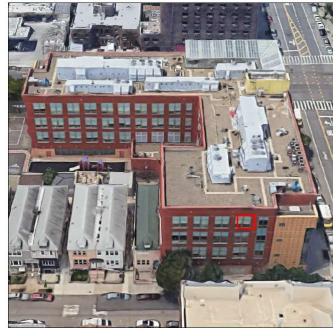
Question	Response
EXTERIOR	
STAIRS/RAMPS: EXTERIOR	Inspected
STAIRS/RAMPS	
Deficiency	No deficiencies recorded
WINDOWS	Inspected
Replacement Quantity	9,000
Replacement Uom	S.F.
EXTERIOR GUARDS	Inspected
Condition	2 - Between Good and Fair
Deficiency	No deficiencies recorded
LINTELS	Inspected
Condition	2 - Between Good and Fair
Deficiency	No deficiencies recorded
WINDOWS	Inspected
Material Type(s)	Aluminum
Instance on Aluminum - Other: All Facades	Inspected
Instance Condition	2 - Between Good and Fair
Instance Quantity	9,000
Instance Quantity Uom	S.F.
Are these windows insulated	Yes
Installation Year	2009
Source of Installation	Custodial Staff
Deficiency	ALUMINUM - OTHER: BROKEN PANE
Roof Plan reference	
Elevation	
Deficiency Quantity	60
Quantity Uom	S.F.
Potential Action	MAINTENANCE
Urgency of Action	PRIORITY 3
Purpose of Action	LEVEL 2

**NYC Department of Education
Building Condition Assessment Survey 2023 - 2024**

Architectural Inspection

K237

Question	Response
EXTERIOR	
WINDOWS	Inspected
WINDOWS	
Deficiency Photo1	
Violations	Facade B - Room 407 No violations recorded.
INTERIOR	Inspected
POOLS	Does not Exist
STRUCTURAL	Inspected
COLUMNS/BEAMS/BEARING WALLS	Inspected
Condition	2 - Between Good and Fair
Deficiency	No deficiencies recorded
FLOOR STRUCTURE	Inspected
Condition	2 - Between Good and Fair
Deficiency	CONCRETE SLAB ON GRADE: THRU CRACKS
Deficiency Location/Instance	Basement - Electrical Panel Room, Sump Pump Room
Deficiency Quantity	20
Quantity Uom	S.F.
Potential Action	REPAIR
Urgency of Action	PRIORITY 3
Purpose of Action	LEVEL 5
Deficiency Photo1	
Violations	Basement - Electrical Panel Room No violations recorded.
FOUNDATION WALLS	Inspected
Material Type(s)	Concrete
Condition	4 - Between Fair and Poor
Deficiency	CONCRETE: WATER INFILTRATION IN ELECTRICAL PANEL ROOM
Deficiency Location/Instance	Basement - Electrical Panel Room
Deficiency Quantity	100
Quantity Uom	S.F.
Potential Action	INSTALL WATERPROOFING
Urgency of Action	PRIORITY 5

**NYC Department of Education
Building Condition Assessment Survey 2023 - 2024**

Architectural Inspection

K237

Question	Response
INTERIOR	
STRUCTURAL	
FOUNDATION WALLS	
Purpose of Action	LEVEL 6
Deficiency Photo1	
Violations	Basement - Electrical Panel Room No violations recorded.
ROOF STRUCTURE	
Condition	Inspected
Deficiency	2 - Between Good and Fair
Deficiency	No deficiencies recorded
VAULTS-BUNKERS	
Violations	Does not Exist
AUDITORIUM	
Instance on 1st Floor (344 Seats)	Inspected
Instance on 1st Floor (344 Seats)	Inspected
Ceiling	
Instance on 1st Floor (344 Seats)	Inspected
Condition	2 - Between Good and Fair
Deficiency	GYPSUM BOARD: DAMAGED/DETERIORATED
Deficiency Location/Instance	Center, Right and Left Side, near Entrance
Deficiency Quantity	50
Quantity Uom	S.F.
Potential Action	REPLACE
Urgency of Action	PRIORITY 3
Purpose of Action	LEVEL 2
Deficiency Photo1	
Violations	Center No violations recorded.
Door(s)	
Instance on 1st Floor (344 Seats)	Inspected
Condition	2 - Between Good and Fair
Deficiency	No deficiencies recorded
Fixed H/C Lift	
Instance on 1st Floor (344 Seats)	Does not Exist
Fixed Seating	
Instance on 1st Floor (344 Seats)	Inspected

**NYC Department of Education
Building Condition Assessment Survey 2023 - 2024**

Architectural Inspection

K237

Question	Response
----------	----------

INTERIOR

AUDITORIUM

Fixed Seating

Condition	3 - Fair
Deficiency	DAMAGED/BROKEN/INOPERABLE
Deficiency Location/Instance	Seats AA/5, D/3, E/20, J/5
Deficiency Quantity	4
Quantity Uom	EACH
Potential Action	REPLACE
Urgency of Action	PRIORITY 5
Purpose of Action	LEVEL 6
Deficiency Photo1	

Violations	No violations recorded.
------------	-------------------------

Deficiency	DAMAGED/BROKEN/INOPERABLE
Deficiency Location/Instance	Seats C/104, D/104, H/102, J/106,111 and others
Deficiency Quantity	10
Quantity Uom	EACH
Potential Action	REPLACE
Urgency of Action	PRIORITY 3
Purpose of Action	LEVEL 2
Deficiency Photo1	

Violations	No violations recorded.
------------	-------------------------

Floor Finish

Instance on 1st Floor (344 Seats)	Inspected
Condition	2 - Between Good and Fair
Deficiency	CONCRETE: CRACKS
Deficiency Location/Instance	Near Seats B/2, E/16,102,109
Deficiency Quantity	40
Quantity Uom	S.F.
Potential Action	REPLACE
Urgency of Action	PRIORITY 3
Purpose of Action	LEVEL 2

**NYC Department of Education
Building Condition Assessment Survey 2023 - 2024**

Architectural Inspection

K237

Question	Response
----------	----------

INTERIOR

AUDITORIUM

Floor Finish

Deficiency Photo1



Near Seat B/2

Violations

No violations recorded.

Sliding-folding Partition

Instance on 1st Floor (344 Seats)

Does not Exist

Stage

Instance on 1st Floor (344 Seats)

Inspected

Stage

Inspected

Instance on 1st Floor (344 Seats)

Inspected

Condition

2 - Between Good and Fair

Deficiency

No deficiencies recorded

Stage Curtain Rigging

Inspected

Instance on 1st Floor (344 Seats)

Inspected

Condition

2 - Between Good and Fair

Deficiency

No deficiencies recorded

Stage Curtains

Inspected

Instance on 1st Floor (344 Seats)

Inspected

Condition

2 - Between Good and Fair

Deficiency

No deficiencies recorded

Walls

Instance on 1st Floor (344 Seats)

Inspected

Condition

2 - Between Good and Fair

Deficiency

GYPSUM BOARD: DETERIORATED

Deficiency Location/Instance

Right and Left Side Stage

Deficiency Quantity

20

Quantity Uom

S.F.

Potential Action

REPLACE

Urgency of Action

PRIORITY 3

Purpose of Action

LEVEL 2

Deficiency Photo1

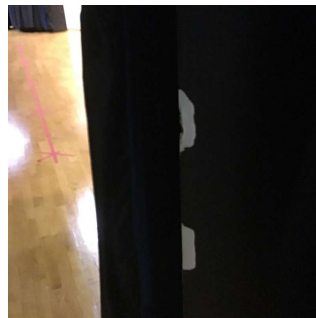



Right Side Stage

**NYC Department of Education
Building Condition Assessment Survey 2023 - 2024**

Architectural Inspection

K237

Question	Response
INTERIOR	
AUDITORIUM	Inspected
Walls	
Violations	No violations recorded.
Window Curtains/Shades/Blinds	
Instance on 1st Floor (344 Seats)	Does not Exist
CAFETERIA	Inspected
Instance on Basement	Inspected
Ceiling	
Instance on Basement	Inspected
Condition	3 - Fair
Deficiency	ACOUSTIC TILES: DAMAGED/MISSING
Deficiency Location/Instance	Near Room C05D, By Entrance
Deficiency Quantity	30
Quantity Uom	S.F.
Potential Action	REPLACE
Urgency of Action	PRIORITY 3
Purpose of Action	LEVEL 2
Deficiency Photo1	
Violations	Near Room C05D No violations recorded.
Deficiency	GYPSUM BOARD: DAMAGED/DETERIORATED
Deficiency Location/Instance	Near Entrance, By Servery, Next Drinking Fountain, Center, Close Room C05D and others
Deficiency Quantity	250
Quantity Uom	S.F.
Potential Action	REPLACE
Urgency of Action	PRIORITY 3
Purpose of Action	LEVEL 2
Deficiency Photo1	
Violations	Near Entrance No violations recorded.
Door(s)	
Instance on Basement	Inspected

**NYC Department of Education
Building Condition Assessment Survey 2023 - 2024**

Architectural Inspection

K237

Question	Response
INTERIOR	
CAFETERIA	Inspected
Door(s)	
Condition	2 - Between Good and Fair
Deficiency	No deficiencies recorded
Fixed Equipment	
Instance on Basement	Does not Exist
Floor Finish	
Instance on Basement	Inspected
Condition	2 - Between Good and Fair
Deficiency	VINYL TILES: DETERIORATED SUBSTRATE
Deficiency Location/Instance	Near Room C05C, By Servery
Deficiency Quantity	20
Quantity Uom	S.F.
Potential Action	REPLACE
Urgency of Action	PRIORITY 3
Purpose of Action	LEVEL 2
Deficiency Photo1	
	Near Room C05C
Violations	No violations recorded.
Sliding-folding Partition	
Instance on Basement	Does not Exist
Stage	
Instance on Basement	Does not Exist
Walls	
Instance on Basement	Inspected
Condition	2 - Between Good and Fair
Deficiency	GYPSUM BOARD: DETERIORATED
Deficiency Location/Instance	Near Entrance, Next Entrance Doors, By Room C05D
Deficiency Quantity	30
Quantity Uom	S.F.
Potential Action	REPLACE
Urgency of Action	PRIORITY 3
Purpose of Action	LEVEL 2

**NYC Department of Education
Building Condition Assessment Survey 2023 - 2024**

Architectural Inspection

K237

Question	Response
----------	----------

INTERIOR

CAFETERIA

Walls

Deficiency Photo1

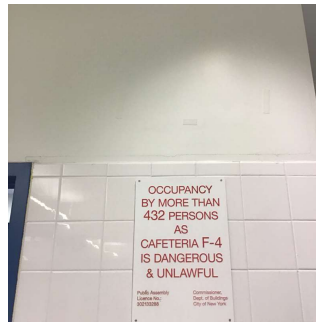

Near Entrance

Violations

No violations recorded.

Deficiency

CERAMIC TILE: BROKEN/ MISSING

Deficiency Location/Instance

Near Servery, By Entrance

Deficiency Quantity

20

Quantity Uom

S.F.

Potential Action

REPLACE

Urgency of Action

PRIORITY 3

Purpose of Action

LEVEL 2

Deficiency Photo1



Near Servery

Violations

No violations recorded.

Window Curtains/Shades/Blinds

Instance on Basement

Does not Exist

CLASSROOMS/CORRIDORS/ADMIN SPACES

Inspected

Ceiling

Inspected

Condition

2 - Between Good and Fair

Deficiency

ACOUSTIC TILES: DAMAGED/MISSING - ACTIVE LEAK

Deficiency Location/Instance

Room C14A

Deficiency Quantity

10

Quantity Uom

S.F.

Potential Action

REPLACE

Urgency of Action

PRIORITY 5



Purpose of Action

LEVEL 2

NYC Department of Education
Building Condition Assessment Survey 2023 - 2024

Architectural Inspection



K237

Question	Response
INTERIOR	
CLASSROOMS/CORRIDORS/ADMIN SPACES	
Door(s)	Inspected
Condition	2 - Between Good and Fair
Deficiency	No deficiencies recorded
Floor Finish	Inspected
Condition	2 - Between Good and Fair
Deficiency	EPOXY FLOORING: CRACKS/SPALLING
Deficiency Location/Instance	Room 320
Deficiency Quantity	10
Quantity Uom	S.F.
Potential Action	REPLACE
Urgency of Action	PRIORITY 3
Purpose of Action	LEVEL 2
Deficiency Photo1	
Room 320	
Violations	No violations recorded.
Deficiency	VINYL TILES: DETERIORATED SUBSTRATE
Deficiency Location/Instance	Corridor near Rooms C40,C42,120, by Gymnasium, next Stair B/Basement and others
Deficiency Quantity	120
Quantity Uom	S.F.
Potential Action	REPLACE
Urgency of Action	PRIORITY 3
Purpose of Action	LEVEL 2
Deficiency Photo1	
Corridor near Room C40	
Violations	No violations recorded.
Deficiency	VINYL TILES: BROKEN/DETERIORATED/MISSING TILES
Deficiency Location/Instance	Corridor near Exits 3,2, next Room C16, by Elevator A/1
Deficiency Quantity	40
Quantity Uom	S.F.
Potential Action	REPLACE
Urgency of Action	PRIORITY 3

**NYC Department of Education
Building Condition Assessment Survey 2023 - 2024**

Architectural Inspection

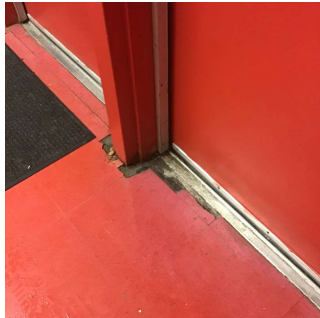
K237

Question	Response
INTERIOR	
CLASSROOMS/CORRIDORS/ADMIN SPACES	
Floor Finish	
Purpose of Action	LEVEL 2
Deficiency Photo1	
Violations	Corridor near Exit 3 No violations recorded.
Walls	
Condition	Inspected 2 - Between Good and Fair
Deficiency	GYPSUM BOARD: DETERIORATED - ACTIVE LEAK
Deficiency Location/Instance	Room C14A
Deficiency Quantity	10
Quantity Uom	S.F.
Potential Action	REPLACE
Urgency of Action	PRIORITY 5
Purpose of Action	LEVEL 2
Deficiency Photo1	
Violations	Room C14A No violations recorded.
Deficiency	CERAMIC TILE: BROKEN/ MISSING
Deficiency Location/Instance	Corridor near Cafeteria, next Gymnasium, By Stairs B/4, C/1, Rooms 337 and others
Deficiency Quantity	80
Quantity Uom	S.F.
Potential Action	REPLACE
Urgency of Action	PRIORITY 3
Purpose of Action	LEVEL 2

**NYC Department of Education
Building Condition Assessment Survey 2023 - 2024**

Architectural Inspection

K237

Question	Response
INTERIOR	
CLASSROOMS/CORRIDORS/ADMIN SPACES	
Walls	
Deficiency Photo1	
Violations	Corridor near Cafeteria No violations recorded.
Deficiency	GYPSUM BOARD: DETERIORATED
Deficiency Location/Instance	Corridor near Cafeteria, By Rooms C44,C36,C32, Next Drinking Fountain - Basement and others
Deficiency Quantity	650
Quantity Uom	S.F.
Potential Action	REPLACE
Urgency of Action	PRIORITY 3
Purpose of Action	LEVEL 2
Deficiency Photo1	
Violations	Corridor near Cafeteria No violations recorded.
Specialties	Does not Exist
GYMNASIUM	Inspected
Instance on Basement	Inspected
Ceiling	
Instance on Basement	Inspected
Condition	2 - Between Good and Fair
Deficiency	GYPSUM BOARD: DAMAGED/DETERIORATED
Deficiency Location/Instance	Near Drinking Fountain, Close Entrance, By Stair A/Basement, Center, Next Lockers Room
Deficiency Quantity	120
Quantity Uom	S.F.
Potential Action	REPLACE
Urgency of Action	PRIORITY 3
Purpose of Action	LEVEL 2

**NYC Department of Education
Building Condition Assessment Survey 2023 - 2024**

Architectural Inspection



K237

Question	Response
INTERIOR	
GYMNASIUM	
Ceiling	
Deficiency Photo1	
Violations	Near Drinking Fountain No violations recorded.
Deficiency	ACOUSTIC TILES: DAMAGED/MISSING
Deficiency Location/Instance	Room C12
Deficiency Quantity	10
Quantity Uom	S.F.
Potential Action	REPLACE
Urgency of Action	PRIORITY 3
Purpose of Action	LEVEL 2
Deficiency Photo1	
Violations	Room C12 No violations recorded.
Door(s)	
Instance on Basement	Inspected
Condition	2 - Between Good and Fair
Deficiency	No deficiencies recorded
Fixed Equipment	
Instance on Basement	Inspected
Condition	2 - Between Good and Fair
Deficiency	No deficiencies recorded
Floor Finish	
Instance on Basement	Inspected
Condition	3 - Fair
Deficiency	WOOD: DAMAGED/DETERIORATED
Deficiency Location/Instance	Near Sliding Folding Partition
Deficiency Quantity	20
Quantity Uom	S.F.
Potential Action	REPLACE
Urgency of Action	PRIORITY 5
Purpose of Action	LEVEL 6

**NYC Department of Education
Building Condition Assessment Survey 2023 - 2024**

Architectural Inspection

K237

Question	Response
INTERIOR	
GYMNASIUM	
Floor Finish	
Deficiency Photo1	
Violations	Near Sliding Folding Partition No violations recorded.
Deficiency	WOOD: DAMAGED/DETERIORATED
Deficiency Location/Instance	East and West Side, Center
Deficiency Quantity	140
Quantity Uom	S.F.
Potential Action	REPLACE
Urgency of Action	PRIORITY 3
Purpose of Action	LEVEL 2
Deficiency Photo1	
Violations	Center No violations recorded.
Seating	
Instance on Basement	Inspected
Condition	2 - Between Good and Fair
Deficiency	No deficiencies recorded
Sliding-folding Partition	
Instance on Basement	Inspected
Condition	2 - Between Good and Fair
Deficiency	No deficiencies recorded
Stage	
Instance on Basement	Does not Exist
Walls	
Instance on Basement	Inspected
Condition	2 - Between Good and Fair
Deficiency	MASONRY: CRACKS/SPALLING
Deficiency Location/Instance	Near Stair A/Basement
Deficiency Quantity	10
Quantity Uom	S.F.
Potential Action	REPLACE

**NYC Department of Education
Building Condition Assessment Survey 2023 - 2024**

Architectural Inspection

K237

Question	Response
INTERIOR	
GYMNASIUM	
Walls	
Urgency of Action	PRIORITY 3
Purpose of Action	LEVEL 2
Deficiency Photo1	
	Near Stair A/Basement
Violations	No violations recorded.
Deficiency	WALL PADDING: DETERIORATED
Deficiency Location/Instance	West Side
Deficiency Quantity	60
Quantity Uom	S.F.
Potential Action	REPLACE
Urgency of Action	PRIORITY 3
Purpose of Action	LEVEL 2
Deficiency Photo1	
	Left Side
Violations	No violations recorded.
Window Curtains/Shades/Blinds	
Instance on Basement	Does not Exist
INTERIOR DOOR HARDWARE	
Condition	Inspected
Deficiency	2 - Between Good and Fair
Deficiency	No deficiencies recorded
INTERIOR GUARDS	
Condition	Inspected
Deficiency	2 - Between Good and Fair
Deficiency	No deficiencies recorded
KITCHEN	
Instance on Basement	Inspected
Instance on Basement	Inspected
Ceiling	
Instance on Basement	Inspected
Condition	2 - Between Good and Fair
Deficiency	GYPSUM BOARD: DAMAGED/DETERIORATED
Deficiency Location/Instance	Room C03F
Deficiency Quantity	10

**NYC Department of Education
Building Condition Assessment Survey 2023 - 2024**

Architectural Inspection

K237

Question	Response
INTERIOR	
KITCHEN	
Ceiling	
Quantity Uom	S.F.
Potential Action	REPLACE
Urgency of Action	PRIORITY 3
Purpose of Action	LEVEL 2
Deficiency Photo1	
Violations	Room C03F No violations recorded.
Deficiency	METAL PAN: DAMAGED/MISSING
Deficiency Location/Instance	Preparation Area
Deficiency Quantity	10
Quantity Uom	S.F.
Potential Action	REPLACE
Urgency of Action	PRIORITY 3
Purpose of Action	LEVEL 2
Deficiency Photo1	
Violations	Preparation Area No violations recorded.
Door(s)	
Instance on Basement	Inspected
Condition	2 - Between Good and Fair
Deficiency	No deficiencies recorded
Floor Finish	
Instance on Basement	Inspected
Condition	2 - Between Good and Fair
Deficiency	QUARRY TILE: BROKEN/MISSING TILES
Deficiency Location/Instance	Near Fridges, By Room C03F
Deficiency Quantity	20
Quantity Uom	S.F.
Potential Action	REPLACE
Urgency of Action	PRIORITY 3
Purpose of Action	LEVEL 2

**NYC Department of Education
Building Condition Assessment Survey 2023 - 2024**

Architectural Inspection

K237

Question	Response
----------	----------

INTERIOR

KITCHEN

Floor Finish

Deficiency Photo1

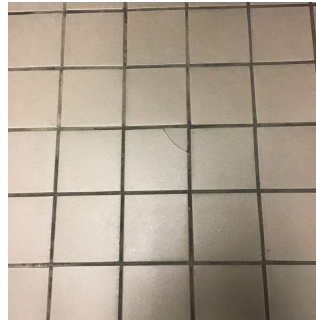

Near Fridges

No violations recorded.

Violations

Walls

Instance on Basement	Inspected
Condition	2 - Between Good and Fair
Deficiency	CERAMIC TILE: BROKEN/ MISSING
Deficiency Location/Instance	Servery
Deficiency Quantity	10
Quantity Uom	S.F.
Potential Action	REPLACE
Urgency of Action	PRIORITY 3
Purpose of Action	LEVEL 2
Deficiency Photo1	



Servery

No violations recorded.

Violations

Deficiency	GYPSUM BOARD: DETERIORATED
Deficiency Location/Instance	Rooms C03B,C03G
Deficiency Quantity	20
Quantity Uom	S.F.
Potential Action	REPLACE
Urgency of Action	PRIORITY 3
Purpose of Action	LEVEL 2

**NYC Department of Education
Building Condition Assessment Survey 2023 - 2024**

Architectural Inspection

K237

Question	Response
INTERIOR	
KITCHEN	Inspected
Walls	
Deficiency Photo1	
Violations	Room C03B No violations recorded.
LIBRARY	Inspected
Instance on Room 314	Inspected
Built-in Furnishing	
Instance on Room 314	Does not Exist
Ceiling	
Instance on Room 314	Inspected
Condition	2 - Between Good and Fair
Deficiency	No deficiencies recorded
Door(s)	
Instance on Room 314	Inspected
Condition	2 - Between Good and Fair
Deficiency	No deficiencies recorded
Floor Finish	
Instance on Room 314	Inspected
Condition	2 - Between Good and Fair
Deficiency	No deficiencies recorded
Walls	
Instance on Room 314	Inspected
Condition	2 - Between Good and Fair
Deficiency	GYPSUM BOARD: DETERIORATED
Deficiency Location/Instance	Room 314
Deficiency Quantity	10
Quantity Uom	S.F.
Potential Action	REPLACE
Urgency of Action	PRIORITY 3
Purpose of Action	LEVEL 2
Deficiency Photo1	
	Room 314

NYC Department of Education
Building Condition Assessment Survey 2023 - 2024

Architectural Inspection

K237

Question	Response
INTERIOR	
LIBRARY	Inspected
Walls	
Violations	No violations recorded.
LOCKER ROOM	Inspected
Instance on Basement - Boys (370 Lockers)	Inaccessible
Instance on Basement - Girls (380 Lockers)	Inaccessible
MULTI-PURPOSE ROOM	Does not Exist
SCIENCE DEMO ROOM	Does not Exist
SCIENCE LAB	Inspected
Instance on Rooms 409,320	Inspected
Alternative use	No
Fixed Equipment	
Instance on Rooms 409,320	Inspected
Condition	2 - Between Good and Fair
Deficiency	No deficiencies recorded
SCIENCE PREP ROOM	Inspected
Instance on Rooms 411,322	Inspected
Alternative use	No
Fixed Equipment	
Instance on Rooms 411,322	Inspected
Condition	2 - Between Good and Fair
Deficiency	No deficiencies recorded
SHOWER ROOM	Does not Exist
STAIRS/RAMPS: INTERIOR	Inspected
Do Letter Stair Signs Exist?	Partially
Ceiling	Inspected
Condition	2 - Between Good and Fair
Deficiency	No deficiencies recorded
Door(s)	Inspected
Condition	2 - Between Good and Fair
Deficiency	No deficiencies recorded
Partition	Does not Exist
Railings	Inspected
Condition	2 - Between Good and Fair
Deficiency	No deficiencies recorded
Stairs and Landings	Inspected
Condition	2 - Between Good and Fair
Deficiency	CONCRETE: CRACKS/SPALLING - MAJOR
Deficiency Location/Instance	Stair to GreenHouse
Deficiency Quantity	10
Quantity Uom	S.F.
Potential Action	REPLACE
Urgency of Action	PRIORITY 3
Purpose of Action	LEVEL 2

**NYC Department of Education
Building Condition Assessment Survey 2023 - 2024**

Architectural Inspection

K237

Question	Response
----------	----------

INTERIOR

STAIRS/RAMPS: INTERIOR

Stairs and Landings

Deficiency Photo1

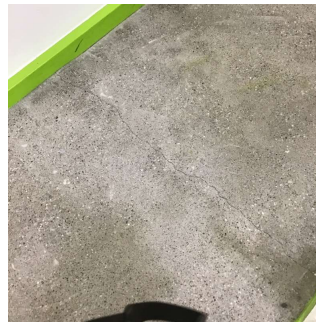

Stair to GreenHouse

Violations

No violations recorded.

Walls

Inspected

Condition

2 - Between Good and Fair

Deficiency

MASONRY: CRACKS/SPALLING

Deficiency Location/Instance

Stairs A/3, B/Basement,

Deficiency Quantity

30

Quantity Uom

S.F.

Potential Action

REPLACE

Urgency of Action

PRIORITY 3

Purpose of Action

LEVEL 2

Deficiency Photo1

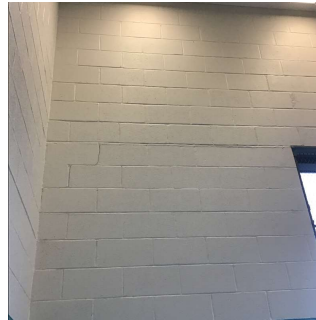

Stair A/3

Violations

No violations recorded.

TOILET ROOMS - STAFF

Inspected

Ceiling

Inspected

Condition

2 - Between Good and Fair

Deficiency

ACOUSTIC TILES: DAMAGED/MISSING

Deficiency Location/Instance

Room 116

Deficiency Quantity

10

Quantity Uom

S.F.

Potential Action

REPLACE

Urgency of Action

PRIORITY 3

Purpose of Action

LEVEL 2

**NYC Department of Education
Building Condition Assessment Survey 2023 - 2024**

Architectural Inspection

K237

Question	Response
INTERIOR	
TOILET ROOMS - STAFF	
Ceiling	
Deficiency Photo1	
Violations	Room 116 No violations recorded.
Door(s)	Inspected
Condition	2 - Between Good and Fair
Deficiency	No deficiencies recorded
Floor Finish	Inspected
Condition	2 - Between Good and Fair
Deficiency	No deficiencies recorded
Stalls	Inspected
Condition	2 - Between Good and Fair
Deficiency	No deficiencies recorded
Walls	Inspected
Condition	2 - Between Good and Fair
Deficiency	CERAMIC TILE: BROKEN/ MISSING
Deficiency Location/Instance	Rooms 118,C14C
Deficiency Quantity	20
Quantity Uom	S.F.
Potential Action	REPLACE
Urgency of Action	PRIORITY 3
Purpose of Action	LEVEL 2
Deficiency Photo1	
Violations	Room 118 No violations recorded.
TOILET ROOMS - STUDENTS	
Ceiling	Inspected
Condition	2 - Between Good and Fair
Deficiency	No deficiencies recorded
Door(s)	Inspected
Condition	2 - Between Good and Fair
Deficiency	No deficiencies recorded

**NYC Department of Education
Building Condition Assessment Survey 2023 - 2024**

Architectural Inspection

K237

Question	Response
INTERIOR	
TOILET ROOMS - STUDENTS	
Floor Finish	Inspected
Condition	2 - Between Good and Fair
Deficiency	No deficiencies recorded
Stalls	Inspected
Condition	2 - Between Good and Fair
Deficiency	No deficiencies recorded
Walls	Inspected
Condition	2 - Between Good and Fair
Deficiency	PLASTER: CRACKS/SPALLING
Deficiency Location/Instance	Rooms 106A,108A,110A,112A, In Room 124 and others
Deficiency Quantity	90
Quantity Uom	S.F.
Potential Action	REPLACE
Urgency of Action	PRIORITY 3
Purpose of Action	LEVEL 2
Deficiency Photo1	
Violations	Room 106A No violations recorded.
Deficiency	CERAMIC TILE: BROKEN/ MISSING
Deficiency Location/Instance	Room 421
Deficiency Quantity	10
Quantity Uom	S.F.
Potential Action	REPLACE
Urgency of Action	PRIORITY 3
Purpose of Action	LEVEL 2
Deficiency Photo1	
Violations	Room 421 No violations recorded.
LIFE SAFETY	Inspected
F.D. HOLDING AREA	Does not Exist
STEEL STAIRS	Does not Exist
SITE	Inspected

**NYC Department of Education
Building Condition Assessment Survey 2023 - 2024**

Architectural Inspection



K237

Question	Response
SITE	
CONTAINERIZATION	Does not Exist
Drainage System for Asphalt	Inspected
Catch Basins/Manhole - Surrounded by asphalt	Inspected
Condition	2 - Between Good and Fair
Deficiency	No deficiencies recorded
Culverts - Asphalt Covering	Does not Exist
Drainage System for Concrete	Does not Exist
Drainage System for Soil	Does not Exist
DRINKING FOUNTAINS	Does not Exist
FENCES	Inspected
Condition	2 - Between Good and Fair
Deficiency	CONCRETE CURB: DAMAGED/DETERIORATED
Deficiency Location/Instance	Stillwell Avenue
Deficiency Quantity	30
Quantity Uom	S.F.
Potential Action	REPLACE
Urgency of Action	PRIORITY 3
Purpose of Action	LEVEL 2
Deficiency Photo1	
Violations	Stillwell Avenue No violations recorded.
IRRIGATION SYSTEM	Does not Exist
PAVING	Inspected
Student Non-Use	Inspected
Gravel Exists?	No
Asphalt	Does not Exist
Concrete	Does not Exist
Pavers	Does not Exist
Student Use	Inspected
Gravel Exists?	No
Asphalt	Inspected
Condition	3 - Fair
Deficiency	CRACKS - MAJOR
Deficiency Location/Instance	Schoolyard
Deficiency Quantity	400
Quantity Uom	S.F.
Potential Action	REPLACE
Urgency of Action	PRIORITY 3
Purpose of Action	LEVEL 2

**NYC Department of Education
Building Condition Assessment Survey 2023 - 2024**

Architectural Inspection

K237

Question	Response
SITE	
PAVING	
Student Use	
Asphalt	
Deficiency Photo1	
Violations	Schoolyard No violations recorded.
Concrete	Does not Exist
Pavers	Inspected
Condition	2 - Between Good and Fair
Deficiency	DAMAGED/MISSING
Deficiency Location/Instance	Schoolyard, near Emergency Generator Room
Deficiency Quantity	40
Quantity Uom	S.F.
Potential Action	REPLACE
Urgency of Action	PRIORITY 3
Purpose of Action	LEVEL 2
Deficiency Photo1	
Violations	Schoolyard No violations recorded.
Site Sidewalks & Walkways	Inspected
Asphalt	Does not Exist
Concrete	Inspected
Condition	3 - Fair
Deficiency	CRACKS - MAJOR
Deficiency Location/Instance	Stillwell Avenue, Avenue P
Deficiency Quantity	250
Quantity Uom	S.F.
Potential Action	REPLACE
Urgency of Action	PRIORITY 3
Purpose of Action	LEVEL 2

**NYC Department of Education
Building Condition Assessment Survey 2023 - 2024**

Architectural Inspection

K237

Question	Response
SITE	
PAVING	
Site Sidewalks & Walkways	
Concrete	
Deficiency Photo1	
	Stillwell Avenue
Violations	No violations recorded.
Pavers	Does not Exist
DOT Sidewalk	Inspected
Asphalt	Does not Exist
Concrete	Inspected
Condition	3 - Fair
Deficiency	HEAVING
Deficiency Location/Instance	Stillwell Avenue
Deficiency Quantity	25
Quantity Uom	S.F.
Potential Action	REPLACE
Urgency of Action	PRIORITY 3
Purpose of Action	LEVEL 2
Deficiency Photo1	
	Stillwell Avenue
Violations	No violations recorded.
Deficiency	DAMAGED/DETERIORATED/MISSING SECTIONS
Deficiency Location/Instance	Avenue P, W 13th Street, Stillwell Avenue
Deficiency Quantity	400
Quantity Uom	S.F.
Potential Action	REPLACE
Urgency of Action	PRIORITY 3
Purpose of Action	LEVEL 2

**NYC Department of Education
Building Condition Assessment Survey 2023 - 2024**

Architectural Inspection

K237

Question	Response
SITE	
PAVING	
DOT Sidewalk	
Concrete	
Deficiency Photo1	
Violations	Avenue P No violations recorded.
Deficiency	DAMAGED CURBS
Deficiency Location/Instance	Avenue P
Deficiency Quantity	30
Quantity Uom	L.F.
Potential Action	REPLACE
Urgency of Action	PRIORITY 3
Purpose of Action	LEVEL 2
Deficiency Photo1	
Violations	Avenue P No violations recorded.
Pavers	Does not Exist
PLAYGROUNDS	Inspected
Instance on Schoolyard - Plaza Deck	Inspected
Benches	
Instance on Schoolyard - Plaza Deck	Does not Exist
Fence	
Instance on Schoolyard - Plaza Deck	Inspected
Condition	2 - Between Good and Fair
Deficiency	CONCRETE CURB: DAMAGED/DETERIORATED
Deficiency Location/Instance	Near Schoolyard
Deficiency Quantity	20
Quantity Uom	S.F.
Potential Action	REPLACE
Urgency of Action	PRIORITY 3
Purpose of Action	LEVEL 2

**NYC Department of Education
Building Condition Assessment Survey 2023 - 2024**

Architectural Inspection

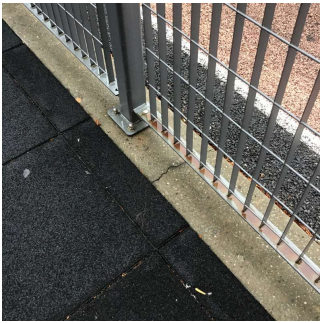

K237

Question	Response
SITE	
PLAYGROUNDS	
Fence	
Deficiency Photo1	
Violations	Near Schoolyard No violations recorded.
Pavement	
Instance on Schoolyard - Plaza Deck	Does not Exist
Play Equipment	
Instance on Schoolyard - Plaza Deck	Inspected
Condition	2 - Between Good and Fair
Deficiency	No deficiencies recorded
Safety Surfacing	
Instance on Schoolyard - Plaza Deck	Inspected
Condition	1 - Good
Deficiency	No deficiencies recorded
Unpaved Area	
Instance on Schoolyard - Plaza Deck	Does not Exist
PLAYING SURFACE	Does not Exist
RETAINING WALLS	Does not Exist
SEATING	Inspected
Benches	Inspected
Concrete	Does not Exist
Metal/Wood/Plastic	Inspected
Condition	2 - Between Good and Fair
Deficiency	No deficiencies recorded
Bleachers	Does not Exist
SITE WALLS (NOT RETAINING WALLS)	Inspected
Condition	3 - Fair
Deficiency	MASONRY UNIT: CRACKS/SPALLING - MAJOR
Deficiency Location/Instance	Schoolyard, near Playground
Deficiency Quantity	70
Quantity Uom	S.F.
Potential Action	REPLACE
Urgency of Action	PRIORITY 3
Purpose of Action	LEVEL 2

**NYC Department of Education
Building Condition Assessment Survey 2023 - 2024**

Architectural Inspection

K237

Question	Response
SITE	
SITE WALLS (NOT RETAINING WALLS)	
Deficiency Photo1 Violations	 Schoolyard No violations recorded.
STAIRS/RAMPS: EXTERIOR	
ARTWORK	Inspected
Instance Instance Photo	Interior - Entrance Lobby - 30153  Entrance Lobby
Instance ID Artwork exist at stated location?	30153 Yes