

**NYC Department of Education**  
**Building Condition Assessment Survey 2023 - 2024**

Architectural Inspection

**K219**

**Asset: P.S. 219 - BROOKLYN, 1060 CLARKSON AVENUE, New York, 11212**

Inspection Id	Inspection Type	Time In	Last Edited
SA : K219	Architectural - Senior	2024-04-30 7:30 AM	2024-06-16 9:52 AM
AA : K219	Architectural - Associate	2024-04-30 7:31 AM	2024-05-09 7:38 PM

**Asset Data**

Question	Answer
Was the building fully accessible for inspection	No
Inspection Access Comment	4th Floor Shower Room (storage)
Building Square Footage	96,000
Comments on the Area (for Athletic Field, Playing Surfaces, Leased Spaces)	None
Comments on the Stories (Floors) plus Basements	4+B
Comments on the Number of Classrooms	47
Comments on the Year Built	1926
Student Population	510
Staff Population	120
Weather	Fair
Principal(s) Information	
Principal Name	Cierra Williams
Organization	P.S. 219 - Brooklyn
Did you meet with this Principal?	No
Did this Principal provide feedback?	No
Principal Name	Alfred Cockfield
Organization	Lamar Academy Charter School - Brooklyn
Did you meet with this Principal?	No
Did this Principal provide feedback?	No
Custodian	Robert Washington
Fireman	Luis Colón
Facade Photo	



Corner of East 93rd Street and Clarkson Avenue - East view

**NYC Department of Education  
Building Condition Assessment Survey 2023 - 2024**

Architectural Inspection

K219

Main Entrance Photo



Facade A - East 93rd Street

Roof Photo



Roof 1 - North View

Have any Systems/Major Building Components been upgraded?

Yes

Systems: Chimney, Coping, Cornice, Door Lintels, Parapets, Leaders/Gutters/Downspouts/Scuppers, Roof Barrier, Roofing, Roof Drains, Exterior Guards, Window Lintels, Vault Bunker Doors and Frame - replacement; Exterior Walls, Bulkhead, Windows, Foundation Walls (waterproofing), Vault Bunker Slab Structure - repairs

Year: 2019

Systems: 1st Floor Student Toilet Rooms HC compliance - upgraded

Year: 2010

Systems: Areaway Gratings - replacement; Areaway - repairs

Year: 2008

Systems: Windows - replacement

Year: 2000

Have there been any Building Additions?

No

Tandem Schools?

No

Leased Space?

No

**Priority Condition**

Priority Condition Exist	Priority Category	Condition Description	Component Affected	Location Description	Person(s) Notified	Person(s) Title	PhotoImage
(P)							

**NYC Department of Education**  
**Building Condition Assessment Survey 2023 - 2024**

Architectural Inspection

K219

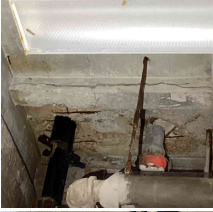
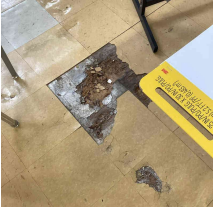
Last Year?							
No	Potential Falling Debris	Deteriorated concrete fireproofing presents a hazard.	INTERIOR   STRUCTURAL   COLUMNS/BEAMS/BEARING WALLS	Basement Tile Storage Room	Robert Washington	Custodian	
No	Tripping Hazard	Severely damaged Vinyl Tiles Floor is a potential tripping hazard.	INTERIOR   CLASSROOMS /CORRIDORS/ ADMIN SPACES   Floor Finish	Room 413	Luis Colon	Fireman	

Structural Engineer Required

Structural Condition Type	Condition Description	Component Affected	Location Description	Person(s) Notified	Person(s) Title	PhotoImage
Deteriorated Steel	Severely rusted steel beam is a potential structural concern	INTERIOR   STRUCTURAL   VAULTS-BUNKERS   Slab Structure	Vault at Boiler Room	Robert Washington	Custodian	

Programmatic Accessibility

Programmatic Accessibility Status Question	Response
Is the primary or secondary entrance on an accessible route?	Yes
Is the building a multi-story building?	Yes
Are all floors of the building accessible through compliant means?	No
Are SOME floors other than the 1st floor and basement accessible through compliant means?	No
Do any of the following spaces exist on the 1st Floor or Basement? Classroom, Art Room, Auditorium, Cafeteria, Computer, Gymnasiums, Library, Multipurpose Room, Science Labs	Yes
For the rooms that do exist, are SOME of them accessible on the 1st Floor or Basement?	Yes
Boys and Girls or Unisex accessible toilets exist on the 1st floor?	Yes

Physical Breakdown Structure	Exists	Required	Complies	Deficiency	Assistive Fire Listening System	Fire Alarm Strobe
------------------------------	--------	----------	----------	------------	---------------------------------	-------------------

PROGRAMMATIC ACCESSIBILITY						
<b>Exterior Routes</b>						
Exterior Entrances & Exits			Yes			
Exterior H/C Lifts	No	No				
Exterior Ramps and Railings	Yes		Yes			
<b>Interior Routes</b>						
Corridor and Lobby H/C Lifts	No	Yes				
Interior Corridor Doors and Hardware	Yes		Yes			
Interior Corridors and Lobbies			No	Change in Elevation		
Interior Elevators	No					

**NYC Department of Education**  
**Building Condition Assessment Survey 2023 - 2024**

Architectural Inspection

**K219**

Physical Breakdown Structure	Exists	Required	Complies	Deficiency	Assistive Listening System	Fire Alarm Strobe
<b>Interior Routes</b>						
Interior Lobby Doors and Hardware			Yes			
Interior Ramps	No					
<b>Rooms &amp; Spaces</b>						
Art Rooms	No					
Auditorium	1st Floor	Yes	No	No Stage Access	FM System	Yes
Cafeteria	1st Floor	Yes	Yes		No	Yes
Classrooms	1st Floor	Yes	Yes			
Computer Rooms	Room 208	Yes	No	Not on Accessible Route		
Gymnasium	3rd Floor, 4th Floor	Yes	No	Not on Accessible Route	No	Yes
Library		No				
Main Office	Room 216 (P.S. 219), Room 415 (Lamad Academy)	Yes	No	Not on Accessible Route		
Multi-purpose Room		No				
Nurse's Room	Room 106	Yes	Yes			
Pool		No				
Science Lab		No				
Toilet Rooms (Boys)	1st Floor	Yes	Yes			
Toilet Rooms (Girls)	1st Floor	Yes	Yes			
Toilet Rooms (Staff)	1st Floor	Yes	Yes			

Building Template

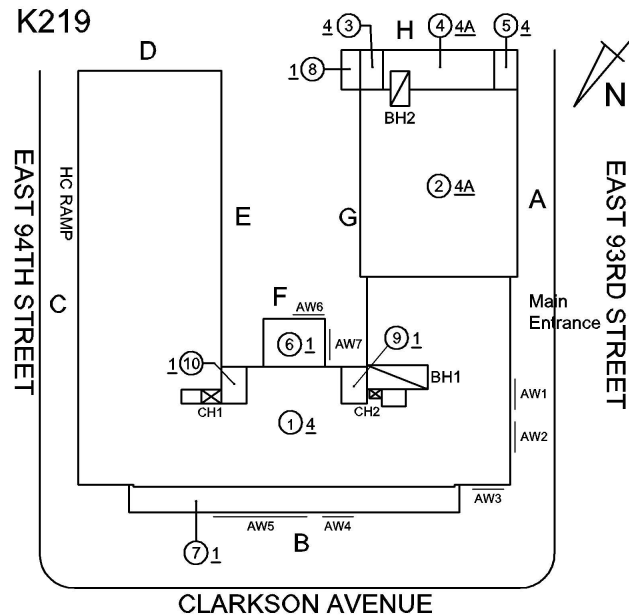



Inspection

Question	Response
<b>Architectural</b>	
<b>EXTERIOR</b>	Inspected
<b>AREAWAY</b>	Inspected
Instance on AW1-AW7	Inspected

**NYC Department of Education  
Building Condition Assessment Survey 2023 - 2024**

Architectural Inspection

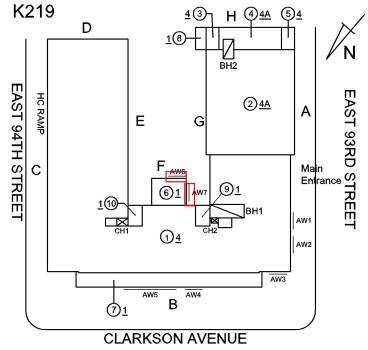

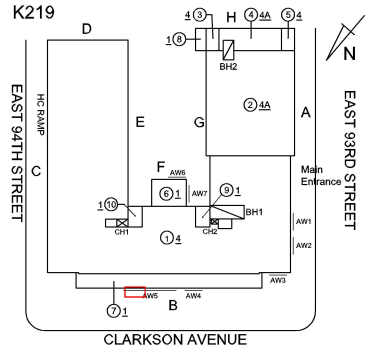
**K219**

Question	Response
<b>EXTERIOR</b>	
<b>AREAWAY</b>	
Instance Condition	3 - Fair
Instance Quantity	7
Instance Quantity Uom	EACH
Deficiency	AREAWAY GRATINGS: MAJOR RUSTING / OR BROKEN
Roof Plan reference	<p>K219</p> 
Deficiency Quantity	50
Quantity Uom	S.F.
Potential Action	REPLACE
Urgency of Action	PRIORITY 4
Purpose of Action	LEVEL 2
Deficiency Photo1	
Violations	No violations recorded.
Deficiency	AREAWAY WALLS: CRACKS AND SPALLING
Roof Plan reference	<p>K219</p> 
Deficiency Quantity	20
Quantity Uom	S.F.
Potential Action	REPLACE
Urgency of Action	PRIORITY 4
Purpose of Action	LEVEL 2

**NYC Department of Education  
Building Condition Assessment Survey 2023 - 2024**

Architectural Inspection

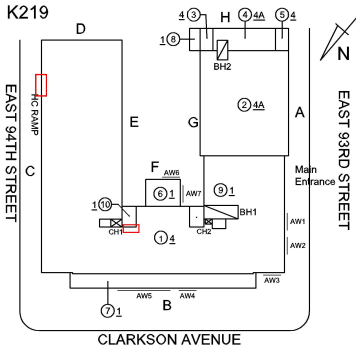
**K219**

Question	Response
<b>EXTERIOR</b>	
<b>AREAWAY</b>	
Deficiency Photo1	
Violations	AW5 No violations recorded.
<b>AWNINGS AND CANOPIES</b>	Does not Exist
<b>CHIMNEY</b>	Inspected
Material Type(s)	Masonry
Condition	1 - Good
Deficiency	No deficiencies recorded
<b>COPING</b>	Inspected
Condition	3 - Fair
Deficiency	CAST STONE: DETERIORATED BED JOINT
Roof Plan reference	K219 
Deficiency Quantity	25
Quantity Uom	L.F.
Potential Action	REPOINT
Urgency of Action	PRIORITY 3
Purpose of Action	LEVEL 2
Deficiency Photo1	
Violations	Roof 1 No violations recorded.
Deficiency	CAST STONE: DETERIORATED TRANSVERSE JOINTS

**NYC Department of Education**  
**Building Condition Assessment Survey 2023 - 2024**

Architectural Inspection

**K219**

**Question**

**Response**

**EXTERIOR**

**COPING**

Roof Plan reference

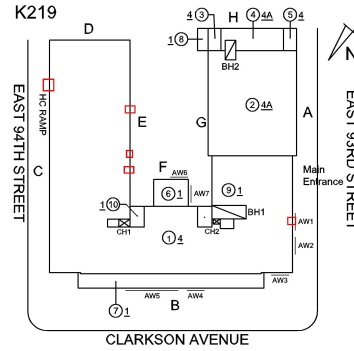

Deficiency Quantity  
 Quantity Uom  
 Potential Action  
 Urgency of Action  
 Purpose of Action  
 Deficiency Photo1

30  
 L.F.  
 MAINTENANCE  
 PRIORITY 3  
 LEVEL 2



Roof 1  
 No violations recorded.

Violations

**CORNICE**

Inspected

Condition

1 - Good

Deficiency

No deficiencies recorded

**DOORS**

Inspected

**DOORS AND FRAMES**

Inspected

Condition

3 - Fair

Deficiency

ROLL-UP DOOR: DETERIORATED DOOR - MINOR DETERIORATION

Roof Plan reference

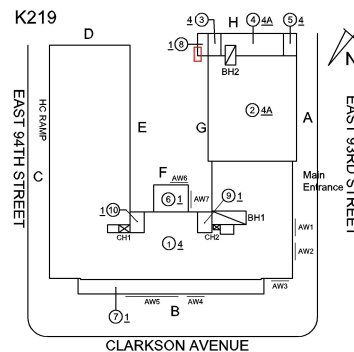



Deficiency Quantity  
 Quantity Uom  
 Potential Action  
 Urgency of Action  
 Purpose of Action

60  
 S.F.  
 MAINTENANCE  
 PRIORITY 3  
 LEVEL 2

**NYC Department of Education  
Building Condition Assessment Survey 2023 - 2024**

Architectural Inspection

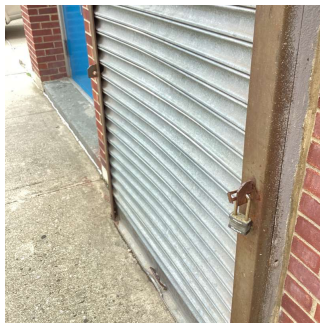
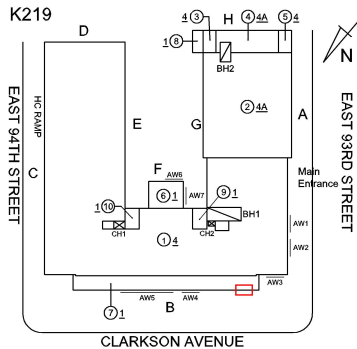
**K219**



Question	Response
<b>EXTERIOR</b>	
<b>DOORS</b>	
<b>DOORS AND FRAMES</b>	
Deficiency Photo1	
Violations	Facade G No violations recorded.
Deficiency	METAL: DETERIORATED DOOR AND FRAME - MINOR DETERIORATION
Roof Plan reference	K219 
Deficiency Quantity	2
Quantity Uom	EACH
Potential Action	MAINTENANCE
Urgency of Action	PRIORITY 3
Purpose of Action	LEVEL 2
Deficiency Photo1	
Violations	Facade B No violations recorded.
<b>DOOR HARDWARE</b>	Inspected
Condition	3 - Fair
Deficiency	No deficiencies recorded
<b>LINTELS</b>	Inspected
Condition	1 - Good
Deficiency	No deficiencies recorded
<b>TRANSOM/SIDE LIGHT</b>	Does not Exist
<b>EXTERIOR WALLS</b>	Inspected



**NYC Department of Education  
Building Condition Assessment Survey 2023 - 2024**

Architectural Inspection

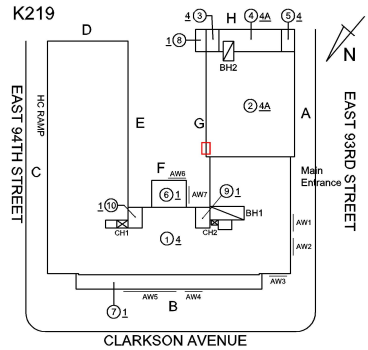
**K219**

Question	Response
<b>EXTERIOR</b>	
<b>EXTERIOR WALLS</b>	
Material Type(s)	Masonry
Replacement Quantity	36,000
Replacement Uom	S.F.
Instance on All Facades	Inspected
Instance Condition	3 - Fair
Instance Quantity	36,000
Instance Quantity Uom	S.F.
Deficiency	BRICK: MASONRY SILLS - DETERIORATED JOINTS
Roof Plan reference	<p>K219</p> 
Elevation	
Deficiency Quantity	10
Quantity Uom	L.F.
Potential Action	REPOINT
Urgency of Action	PRIORITY 3
Purpose of Action	LEVEL 2
Deficiency Photo1	
Violations	Facade G No violations recorded.
Deficiency	BRICK: DETERIORATED MASONRY SILLS - MINOR

**NYC Department of Education  
Building Condition Assessment Survey 2023 - 2024**

Architectural Inspection

**K219**

**Question**

**Response**

**EXTERIOR**

**EXTERIOR WALLS**

Roof Plan reference

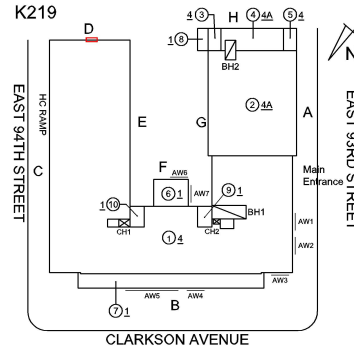

Elevation



Deficiency Quantity

10

Quantity Uom

L.F.

Potential Action

REPAIR

Urgency of Action

PRIORITY 3

Purpose of Action

LEVEL 2

Deficiency Photo1



Facade D

Violations

No violations recorded.

Deficiency

STONE: CHIPPED/SPALLED/BROKEN PIECES - MINOR

Roof Plan reference

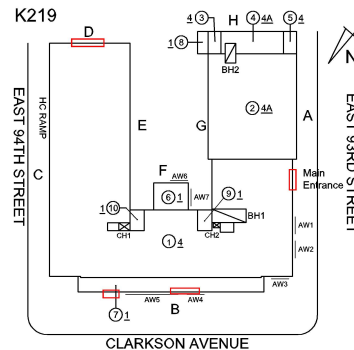

**NYC Department of Education  
Building Condition Assessment Survey 2023 - 2024**

Architectural Inspection

K219

**Question**

**Response**

**EXTERIOR**

**EXTERIOR WALLS**

Elevation

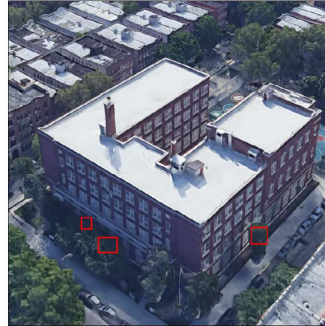

Deficiency Quantity

50

Quantity Uom

S.F.

Potential Action

REPAIR

Urgency of Action

PRIORITY 3

Purpose of Action

LEVEL 2

Deficiency Photo1

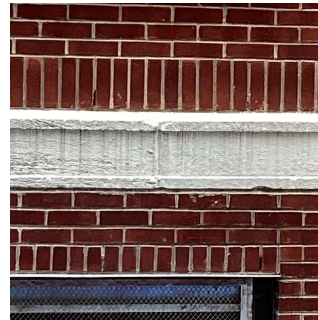

Facade B

Violations

No violations recorded.

Deficiency

BRICK: EFFLORESCENCE

Roof Plan reference

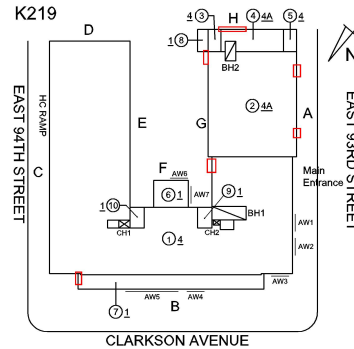

Elevation



Deficiency Quantity

100

Quantity Uom

S.F.

Potential Action

MAINTENANCE

**NYC Department of Education  
Building Condition Assessment Survey 2023 - 2024**

Architectural Inspection

**K219**

**Question**

**Response**

**EXTERIOR**

**EXTERIOR WALLS**

Urgency of Action  
Purpose of Action  
Deficiency Photo1

PRIORITY 1  
LEVEL 1



Facade A

Violations

No violations recorded.

Deficiency

**BRICK: WATER INFILTRATION IN INSTRUCTIONAL SPACE**

Roof Plan reference

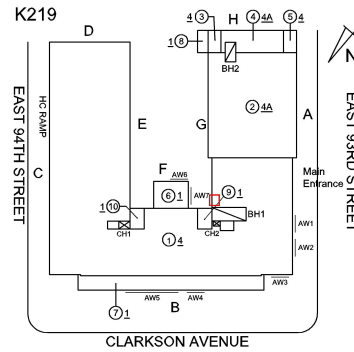

Elevation

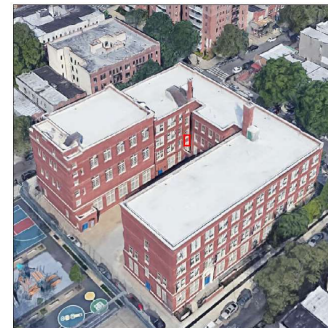

Deficiency Quantity

100

Quantity Uom

S.F.

Potential Action

REPAIR

Urgency of Action

PRIORITY 5

Purpose of Action

LEVEL 2

Deficiency Photo1





Facade G - Stairwell E/3

**NYC Department of Education  
Building Condition Assessment Survey 2023 - 2024**

Architectural Inspection

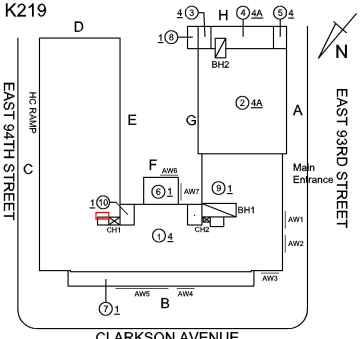
**K219**

Question	Response
<b>EXTERIOR</b>	
<b>EXTERIOR WALLS</b>	Inspected
Violations	No violations recorded.
<b>EXTERIOR SOFFITS</b>	Does not Exist
<b>LOADING DOCK</b>	Does not Exist
<b>LOUVER</b>	Inspected
Condition	3 - Fair
Deficiency	MISSING/DAMAGED SCREEN
Roof Plan reference	<p>K219</p> 
Elevation	
Deficiency Quantity	10
Quantity Uom	S.F.
Potential Action	REPLACE
Urgency of Action	PRIORITY 4
Purpose of Action	LEVEL 2
Deficiency Photo1	
Roof 1	Roof 1
Violations	No violations recorded.
Deficiency	BROKEN/ DENTED BLADES

**NYC Department of Education  
Building Condition Assessment Survey 2023 - 2024**

Architectural Inspection

**K219**

**Question**

**Response**

**EXTERIOR**

**LOUVER**

Roof Plan reference

Inspected

K219

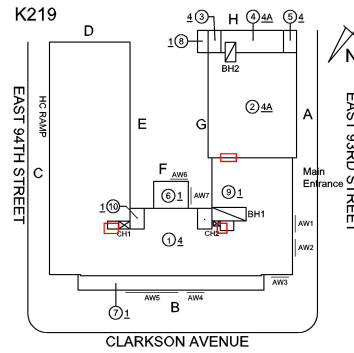

Elevation

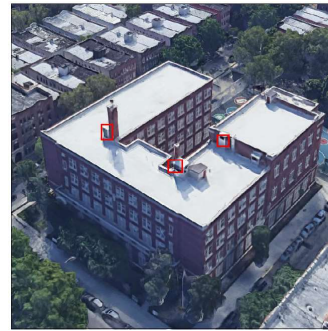

Deficiency Quantity

100

Quantity Uom

S.F.

Potential Action

REPLACE

Urgency of Action

PRIORITY 4

Purpose of Action

LEVEL 2

Deficiency Photo1



Violations

Roof 1

No violations recorded.

**PARAPETS**

Inspected

Material Type(s)

Masonry

Replacement Quantity

6,000

Replacement Uom

C.F.

Instance on All Roofs

Inspected

Instance Condition

1 - Good

Instance Quantity

6,000

Instance Quantity Uom

C.F.

Deficiency

No deficiencies recorded

**PLAZA DECK**

Does not Exist

**ROOF**

Inspected

**Roofing**

Inspected

Replacement Quantity

24,000

**NYC Department of Education**  
**Building Condition Assessment Survey 2023 - 2024**

Architectural Inspection

**K219**

<b>Question</b>	<b>Response</b>
<b>EXTERIOR</b>	
<b>ROOF</b>	
<b>Roofing</b>	
Replacement Uom	S.F.
<b>ROOF HATCH/SMOKE HATCH</b>	Does not Exist
<b>LEADERS, GUTTERS, DOWNSPOUTS, SCUPPERS</b>	Inspected
Condition	1 - Good
Deficiency	No deficiencies recorded
<b>ROOF BARRIER/FENCE</b>	Inspected
Condition	1 - Good
Deficiency	No deficiencies recorded
<b>ROOF CAGE</b>	Does not Exist
<b>ROOFING</b>	Inspected
Instance on Modified Bitumen: All Roofs except Roof 3	Inspected
Instance Condition	1 - Good
Instance Photo	
	Roof 1
Instance Quantity	23,900
Instance Quantity Uom	S.F.
Does the roof have major mechanical equipment sitting on Dunnage Steel less than 18" above the Roofing?	No
Does this roof instance have a Sustainable Roof System?	Yes
Sustainable Roof Type	White Roof
Sustainable Roof Location (Roof Number)	All Roofs
Do solar panels exist on these roofs?	No
Is/Are the roof(s) suitable for Solar Panel installation?	Yes
Installation Year	2019
Source of Installation	Custodial Staff
Deficiency	No deficiencies recorded
Instance on Modified Bitumen: Roof 3	Inspected
Instance Condition	5 - Poor
Instance Photo	
	Roof 3
Instance Quantity	100
Instance Quantity Uom	S.F.
Does the roof have major mechanical equipment sitting on Dunnage Steel less than 18" above the Roofing?	No
Does this roof instance have a Sustainable Roof System?	Yes
Sustainable Roof Type	White Roof
Sustainable Roof Location (Roof Number)	Roof 3
Do solar panels exist on these roofs?	No
Is/Are the roof(s) suitable for Solar Panel installation?	No
Installation Year	2019

**NYC Department of Education  
Building Condition Assessment Survey 2023 - 2024**

Architectural Inspection

**K219**

Question	Response
----------	----------

**EXTERIOR**

**ROOF**

**Roofing**

**ROOFING**

Source of Installation

Custodial Staff

Deficiency

MODIFIED BITUMEN: ROOFING: MAJOR ACTIVE ROOF  
LEAKS IN NON-INSTRUCTIONAL SPACE

Roof Plan reference

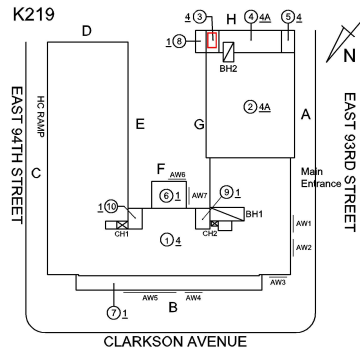

Deficiency Quantity

50

Quantity Uom

S.F.

Potential Action

REPLACE ROOFING WITHOUT MAJOR EQUIPMENT  
REMOVAL

Urgency of Action

PRIORITY 5

Purpose of Action

LEVEL 2

Deficiency Photo1



Roof 3 - Stairwell F/4+

Violations

No violations recorded.

**ROOFING DRAINS**

Inspected

Condition

1 - Good

Deficiency

No deficiencies recorded

**Specialties**

Inspected

**BULKHEAD/PENTHOUSE**

Inspected

Condition

3 - Fair

Deficiency

BULKHEAD/PENTHOUSE WALLS/INTERIOR: PLASTER  
CRACKS/SPALLING

Roof Plan reference

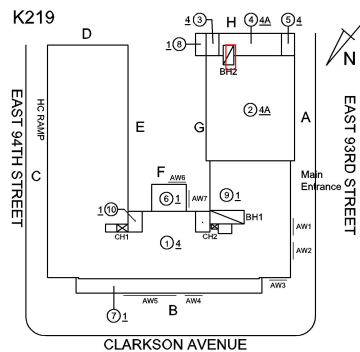



**NYC Department of Education  
Building Condition Assessment Survey 2023 - 2024**

Architectural Inspection

**K219**

Question	Response
----------	----------

**EXTERIOR**

**ROOF**

**Specialties**

**BULKHEAD/PENTHOUSE**

Deficiency Quantity	25
Quantity Uom	S.F.
Potential Action	REPLACE
Urgency of Action	PRIORITY 3
Purpose of Action	LEVEL 2
Deficiency Photo1	



BH2

Violations	No violations recorded.
------------	-------------------------

Deficiency	BULKHEAD/PENTHOUSE WALLS/EXTERIOR: WATER INFILTRATION
------------	---

Roof Plan reference

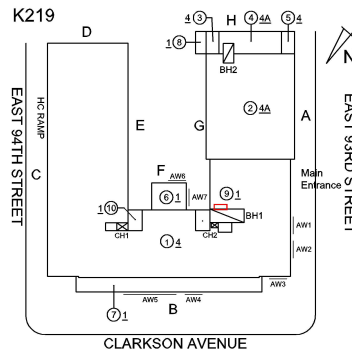

Deficiency Quantity	100
Quantity Uom	S.F.
Potential Action	REPAIR
Urgency of Action	PRIORITY 5
Purpose of Action	LEVEL 2
Deficiency Photo1	



BH1

Violations	No violations recorded.
------------	-------------------------

Deficiency	BULKHEAD/PENTHOUSE WALLS/INTERIOR: PLASTER CRACKS/SPALLING
------------	--

**NYC Department of Education**  
**Building Condition Assessment Survey 2023 - 2024**

Architectural Inspection

**K219**

**Question** **Response**

**EXTERIOR**

**ROOF**

**Specialties**

**BULKHEAD/PENTHOUSE**

Roof Plan reference

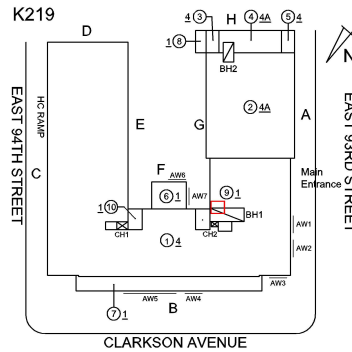

Deficiency Quantity  
 Quantity Uom  
 Potential Action  
 Urgency of Action  
 Purpose of Action  
 Deficiency Photo1

25  
 S.F.  
 REPLACE  
 PRIORITY 4  
 LEVEL 2



BH1  
 No violations recorded.

Violations

**CUPOLA/ SPIRES/ TOWERS**

Does not Exist

**DORMER**

Does not Exist

**DUNNAGE STEEL**

Does not Exist

**SKYLIGHT/ROOF VENT**

Does not Exist

**ROOF/GRAVITY TANK**

Does not Exist

**STAIRS/RAMPS: EXTERIOR**

Inspected

**BUILDING CHEEK/FLANK WALLS**

Inspected

Condition

4 - Between Fair and Poor

Deficiency

BRICK: DETERIORATED JOINTS

Roof Plan reference

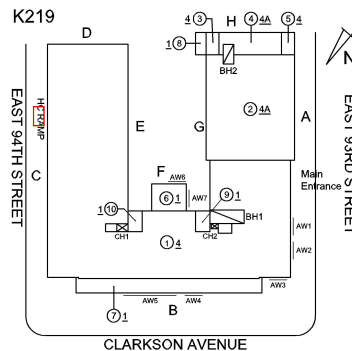

Deficiency Quantity

10

**NYC Department of Education**  
**Building Condition Assessment Survey 2023 - 2024**

Architectural Inspection

K219

**Question**

**Response**

**EXTERIOR**

**STAIRS/RAMPS: EXTERIOR**

**BUILDING CHEEK/FLANK WALLS**

Quantity Uom  
 Potential Action  
 Urgency of Action  
 Purpose of Action  
 Deficiency Photo1

S.F.  
 REPOINT  
 PRIORITY 3  
 LEVEL 2

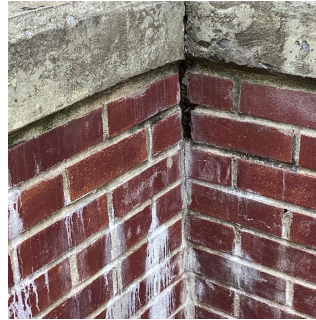

Facade C

No violations recorded.

Violations

Deficiency

Roof Plan reference

CAST IN PLACE CONCRETE: CRACKS/SPALLING - MINOR

K219

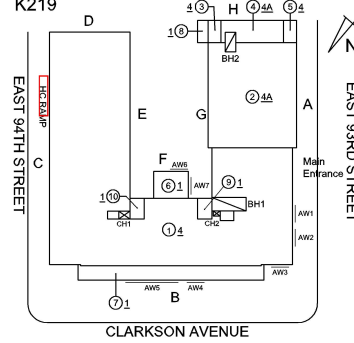

Deficiency Quantity  
 Quantity Uom  
 Potential Action  
 Urgency of Action  
 Purpose of Action  
 Deficiency Photo1

35  
 S.F.  
 REPAIR  
 PRIORITY 3  
 LEVEL 2



Facade C

No violations recorded.

Violations

Deficiency

CAST IN PLACE CONCRETE: CRACKS/SPALLING - MAJOR

**NYC Department of Education**  
**Building Condition Assessment Survey 2023 - 2024**

Architectural Inspection

**K219**

**Question**

**Response**

**EXTERIOR**

**STAIRS/RAMPS: EXTERIOR**

**BUILDING CHEEK/FLANK WALLS**

Roof Plan reference

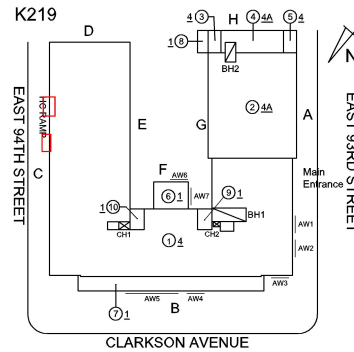

Deficiency Quantity  
 Quantity Uom  
 Potential Action  
 Urgency of Action  
 Purpose of Action  
 Deficiency Photo1

20  
 S.F.  
 REPLACE  
 PRIORITY 4  
 LEVEL 2



Facade C  
 No violations recorded.

Violations

**RAILINGS**

Inspected

Condition

3 - Fair

Deficiency

DAMAGED

Roof Plan reference

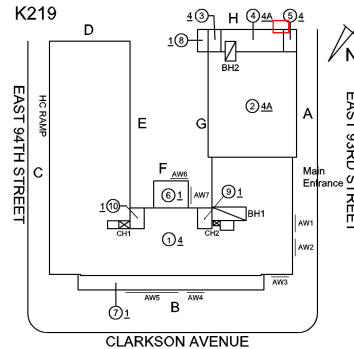

Deficiency Quantity  
 Quantity Uom  
 Potential Action  
 Urgency of Action  
 Purpose of Action

10  
 L.F.  
 REPLACE  
 PRIORITY 4  
 LEVEL 2

**NYC Department of Education  
Building Condition Assessment Survey 2023 - 2024**

Architectural Inspection

**K219**

Question	Response
----------	----------

**EXTERIOR**

**STAIRS/RAMPS: EXTERIOR**

**RAILINGS**

Deficiency Photo1

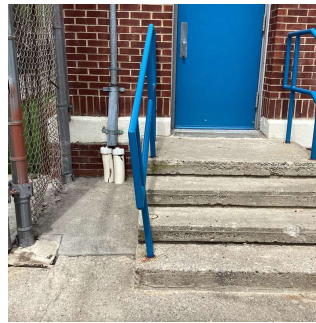

Facade H

No violations recorded.

Violations

**STAIRS/RAMPS**

Inspected

Condition

5 - Poor

Deficiency

STONE: WORN-OUT TREAD/RISER/NOSING

Roof Plan reference

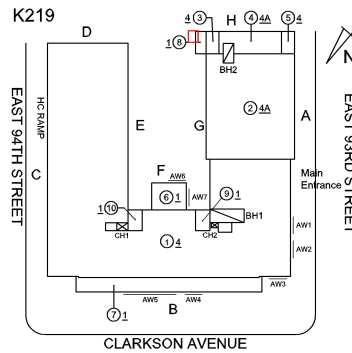

Deficiency Quantity

15

Quantity Uom

S.F.

Potential Action

REPLACE

Urgency of Action

PRIORITY 4

Purpose of Action

LEVEL 2

Deficiency Photo1

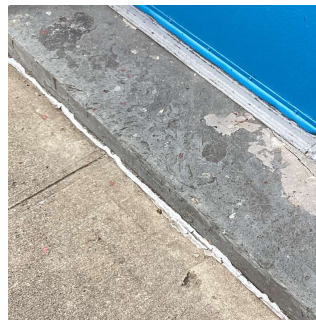

Facade G

No violations recorded.

Violations

Deficiency

STONE: CRACKS/SPALLING - MAJOR

**NYC Department of Education  
Building Condition Assessment Survey 2023 - 2024**

Architectural Inspection

**K219**

**Question**

**Response**

**EXTERIOR**

**STAIRS/RAMPS: EXTERIOR**

**STAIRS/RAMPS**

Roof Plan reference

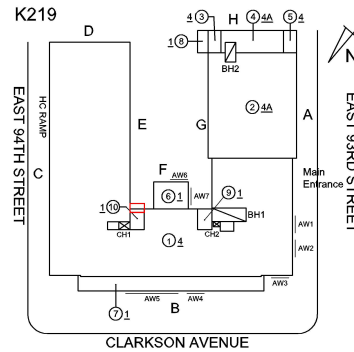

Deficiency Quantity  
Quantity Uom  
Potential Action  
Urgency of Action  
Purpose of Action  
Deficiency Photo1

10  
S.F.  
REPLACE  
PRIORITY 4  
LEVEL 2



Facade F

Violations

No violations recorded.

Deficiency

**CONCRETE: CRACKS/SPALLING - MAJOR**

Roof Plan reference

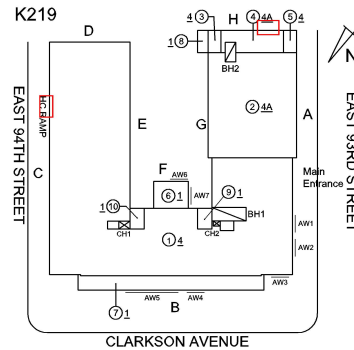



Deficiency Quantity  
Quantity Uom  
Potential Action  
Urgency of Action  
Purpose of Action

30  
S.F.  
REPLACE  
PRIORITY 4  
LEVEL 2

**NYC Department of Education**  
**Building Condition Assessment Survey 2023 - 2024**

Architectural Inspection

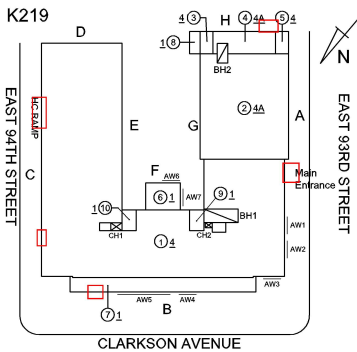
K219

Question	Response
<b>EXTERIOR</b>	
<b>STAIRS/RAMPS: EXTERIOR</b>	
<b>STAIRS/RAMPS</b>	
Deficiency Photo1	
Violations	Facade C No violations recorded.
Deficiency	<b>CONCRETE: CRACKS/SPALLING - MINOR</b>
Roof Plan reference	K219 
Deficiency Quantity	75
Quantity Uom	S.F.
Potential Action	REPAIR
Urgency of Action	PRIORITY 3
Purpose of Action	LEVEL 2
Deficiency Photo1	
Violations	Facade A No violations recorded.
<b>WINDOWS</b>	Inspected
Replacement Quantity	10,000
Replacement Uom	S.F.
<b>EXTERIOR GUARDS</b>	Inspected
Condition	1 - Good
Deficiency	No deficiencies recorded
<b>LINTELS</b>	Inspected
Condition	1 - Good
Deficiency	No deficiencies recorded

**NYC Department of Education  
Building Condition Assessment Survey 2023 - 2024**

Architectural Inspection

**K219**

<b>Question</b>	<b>Response</b>
<b>EXTERIOR</b>	
<b>WINDOWS</b>	
<b>WINDOWS</b>	Inspected
Material Type(s)	Aluminum
Instance on Aluminum - Double Hung: All Facades	Inspected
Instance Condition	3 - Fair
Instance Quantity	8,500
Instance Quantity Uom	S.F.
Are these windows insulated	No
Installation Year	2000
Source of Installation	Custodial Staff
Deficiency	No deficiencies recorded
Instance on Aluminum - Other: All Facades	Inspected
Instance Condition	3 - Fair
Instance Quantity	1,500
Instance Quantity Uom	S.F.
Are these windows insulated	No
Installation Year	2000
Source of Installation	Custodial Staff
Deficiency	No deficiencies recorded
<b>INTERIOR</b>	Inspected
<b>POOLS</b>	Does not Exist
<b>STRUCTURAL</b>	Inspected
<b>COLUMNS/BEAMS/BEARING WALLS</b>	Inspected
Condition	3 - Fair
Deficiency	STEEL COLUMNS/BEAMS: DETERIORATED CONCRETE FIREPROOFING
Deficiency Location/Instance	Basement
Deficiency Quantity	25
Quantity Uom	S.F.
Potential Action	REPLACE
Urgency of Action	PRIORITY 5
Purpose of Action	LEVEL 6
Deficiency Photo1	
	Basement Tile Storage Room
Violations	No violations recorded.
Deficiency	STEEL COLUMNS/BEAMS: DETERIORATED CONCRETE FIREPROOFING
Deficiency Location/Instance	Basement
Deficiency Quantity	45
Quantity Uom	S.F.
Potential Action	REPLACE



**NYC Department of Education  
Building Condition Assessment Survey 2023 - 2024**

Architectural Inspection

**K219**

Question	Response
----------	----------

**INTERIOR**

**STRUCTURAL**

**COLUMNS/BEAMS/BEARING WALLS**

Urgency of Action  
Purpose of Action  
Deficiency Photo1

PRIORITY 4  
LEVEL 5



West Crawl Space (Basement Tile Storage Room similar)

Violations

No violations recorded.

Deficiency

STEEL COLUMNS/BEAMS: DETERIORATED CONCRETE FIREPROOFING

Deficiency Location/Instance

Basement

Deficiency Quantity

370

Quantity Uom

S.F.

Potential Action

REPLACE

Urgency of Action

PRIORITY 3

Purpose of Action

LEVEL 5

Deficiency Photo1



East Crawl Space (West Crawl Space, Boiler Room, Basement Corridor, Basement Fan Area, Basement Tile Storage Room similar)

Violations

No violations recorded.

**FLOOR STRUCTURE**

Inspected

Condition

3 - Fair

Deficiency

CONCRETE SLAB ON GRADE: THRU CRACKS

Deficiency Location/Instance

Basement

Deficiency Quantity

10

Quantity Uom

S.F.

Potential Action

REPLACE

Urgency of Action

PRIORITY 4

Purpose of Action



LEVEL 5



**NYC Department of Education  
Building Condition Assessment Survey 2023 - 2024**

Architectural Inspection

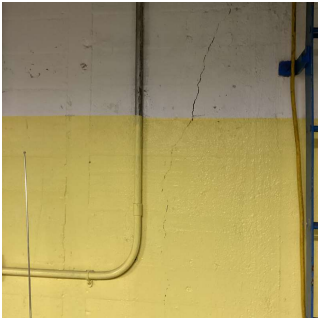

**K219**

<b>Question</b>	<b>Response</b>
<b>INTERIOR</b>	
<b>STRUCTURAL</b>	
<b>FOUNDATION WALLS</b>	Inspected
Material Type(s)	Concrete
Condition	3 - Fair
Deficiency	CONCRETE: CRACKED/SPALLED/REINFORCEMENT EXPOSED
Deficiency Location/Instance	Basement
Deficiency Quantity	30
Quantity Uom	S.F.
Potential Action	REPAIR
Urgency of Action	PRIORITY 3
Purpose of Action	LEVEL 5
Deficiency Photo1	
Violations	Basement Corridor No violations recorded.
<b>ROOF STRUCTURE</b>	Inspected
Condition	2 - Between Good and Fair
Deficiency	No deficiencies recorded
<b>VAULTS-BUNKERS</b>	Inspected
<b>Foundation Walls</b>	Inspected
Condition	3 - Fair
Deficiency	CRACKS, SPALLING
Deficiency Location/Instance	Vault
Deficiency Quantity	40
Quantity Uom	S.F.
Potential Action	REPAIR
Urgency of Action	PRIORITY 3
Purpose of Action	LEVEL 5
Deficiency Photo1	
Violations	Vault No violations recorded.
<b>Slab Structure</b>	Inspected
Condition	3 - Fair

**NYC Department of Education  
Building Condition Assessment Survey 2023 - 2024**

Architectural Inspection



**K219**

Question	Response
<b>INTERIOR</b>	
<b>STRUCTURAL</b>	
<b>VAULTS-BUNKERS</b>	
<b>Slab Structure</b>	
Deficiency	STEEL COLUMNS/BEAMS: MAJOR RUSTING
Deficiency Location/Instance	Vault
Deficiency Quantity	30
Quantity Uom	S.F.
Potential Action	REPLACE
Urgency of Action	PRIORITY 5
Purpose of Action	LEVEL 6
Deficiency Photo1	
Violations	Vault No violations recorded.
Deficiency	STEEL COLUMNS/BEAMS: DETERIORATED CONCRETE FIREPROOFING
Deficiency Location/Instance	Vault
Deficiency Quantity	40
Quantity Uom	S.F.
Potential Action	REPAIR
Urgency of Action	PRIORITY 4
Purpose of Action	LEVEL 5
Deficiency Photo1	
Violations	Vault No violations recorded.
<b>Vault/Ash Hoist Doors and Framing</b>	Inspected
Condition	5 - Poor
Deficiency	DETERIORATED/DAMAGED VAULT/ASH HOIST DOORS AND FRAMING
Deficiency Location/Instance	Vault
Deficiency Quantity	1
Quantity Uom	EACH
Potential Action	REPLACE
Urgency of Action	PRIORITY 4
Purpose of Action	LEVEL 2

**NYC Department of Education  
Building Condition Assessment Survey 2023 - 2024**

Architectural Inspection

K219

Question	Response
<b>INTERIOR</b>	
<b>STRUCTURAL</b>	
<b>VAULTS-BUNKERS</b>	
<b>Vault/Ash Hoist Doors and Framing</b>	
Deficiency Photo1	
Violations	Vault No violations recorded.
<b>AUDITORIUM</b>	
Instance on 1st Floor (616 Seats)	Inspected
<b>Ceiling</b>	Inspected
Instance on 1st Floor (616 Seats)	Inspected
Condition	2 - Between Good and Fair
Deficiency	No deficiencies recorded
<b>Door(s)</b>	
Instance on 1st Floor (616 Seats)	Inspected
Condition	3 - Fair
Deficiency	WOOD: DETERIORATED DOOR
Deficiency Location/Instance	Left Side Stage
Deficiency Quantity	1
Quantity Uom	EACH
Potential Action	MAINTENANCE
Urgency of Action	PRIORITY 3
Purpose of Action	LEVEL 2
Deficiency Photo1	
Violations	Left Side Stage No violations recorded.
<b>Fixed H/C Lift</b>	
Instance on 1st Floor (616 Seats)	Does not Exist
<b>Fixed Seating</b>	
Instance on 1st Floor (616 Seats)	Inspected
Condition	2 - Between Good and Fair
Deficiency	DAMAGED/BROKEN/INOPERABLE
Deficiency Location/Instance	Seat E/1
Deficiency Quantity	1

**NYC Department of Education  
Building Condition Assessment Survey 2023 - 2024**

Architectural Inspection

**K219**

Question	Response
<b>INTERIOR</b>	
<b>AUDITORIUM</b>	
<b>Fixed Seating</b>	
Quantity Uom	EACH
Potential Action	REPLACE
Urgency of Action	PRIORITY 3
Purpose of Action	LEVEL 2
Deficiency Photo1	
Violations	Seat E/1 No violations recorded.
<b>Floor Finish</b>	
Instance on 1st Floor (616 Seats)	Inspected
Condition	2 - Between Good and Fair
Deficiency	CONCRETE: CRACKS
Deficiency Location/Instance	Right and Left Side, Near Seat X/5
Deficiency Quantity	30
Quantity Uom	S.F.
Potential Action	REPLACE
Urgency of Action	PRIORITY 3
Purpose of Action	LEVEL 2
Deficiency Photo1	
Violations	Near Seat X/5 No violations recorded.
Deficiency	VINYL TILES: DETERIORATED SUBSTRATE
Deficiency Location/Instance	Near Stage, between Seats J/1, 2
Deficiency Quantity	30
Quantity Uom	S.F.
Potential Action	REPLACE
Urgency of Action	PRIORITY 3
Purpose of Action	LEVEL 2

**NYC Department of Education  
Building Condition Assessment Survey 2023 - 2024**

Architectural Inspection

K219

Question	Response
<b>INTERIOR</b>	
<b>AUDITORIUM</b>	
<b>Floor Finish</b>	
Deficiency Photo1	
Violations	Between Seats J/1, 2 No violations recorded.
<b>Sliding-folding Partition</b>	
Instance on 1st Floor (616 Seats)	Does not Exist
<b>Stage</b>	
Instance on 1st Floor (616 Seats)	Inspected
<b>Stage</b>	Inspected
Instance on 1st Floor (616 Seats)	Inspected
Condition	2 - Between Good and Fair
Deficiency	No deficiencies recorded
<b>Stage Curtain Rigging</b>	
Instance on 1st Floor (616 Seats)	Inspected
Condition	2 - Between Good and Fair
Deficiency	No deficiencies recorded
<b>Stage Curtains</b>	
Instance on 1st Floor (616 Seats)	Inspected
Condition	2 - Between Good and Fair
Deficiency	No deficiencies recorded
<b>Walls</b>	
Instance on 1st Floor (616 Seats)	Inspected
Condition	2 - Between Good and Fair
Deficiency	No deficiencies recorded
<b>Window Curtains/Shades/Blinds</b>	
Instance on 1st Floor (616 Seats)	Inspected
Condition	2 - Between Good and Fair
Deficiency	No deficiencies recorded
<b>CAFETERIA</b>	
Instance on 1st Floor	Inspected
<b>Ceiling</b>	
Instance on 1st Floor	Inspected
Condition	2 - Between Good and Fair
Deficiency	PLASTER: CRACKS/SPALLING
Deficiency Location/Instance	Near Windows
Deficiency Quantity	20
Quantity Uom	S.F.
Potential Action	REPLACE
Urgency of Action	PRIORITY 3
Purpose of Action	LEVEL 2

**NYC Department of Education  
Building Condition Assessment Survey 2023 - 2024**

Architectural Inspection

K219



Question	Response
<b>INTERIOR</b>	
<b>CAFETERIA</b>	
<b>Ceiling</b>	
Deficiency Photo1	
	Near Windows
Violations	No violations recorded.
Deficiency	ACOUSTIC TILES ON PLASTER: DAMAGED/MISSING
Deficiency Location/Instance	Near Windows
Deficiency Quantity	20
Quantity Uom	S.F.
Potential Action	REPLACE
Urgency of Action	PRIORITY 3
Purpose of Action	LEVEL 2
Deficiency Photo1	
	Near Windows
Violations	No violations recorded.
<b>Door(s)</b>	
Instance on 1st Floor	Inspected
Condition	2 - Between Good and Fair
Deficiency	No deficiencies recorded
<b>Fixed Equipment</b>	
Instance on 1st Floor	Inspected
Condition	2 - Between Good and Fair
Deficiency	No deficiencies recorded
<b>Floor Finish</b>	
Instance on 1st Floor	Inspected
Condition	2 - Between Good and Fair
Deficiency	No deficiencies recorded
<b>Sliding-folding Partition</b>	
Instance on 1st Floor	Does not Exist
<b>Stage</b>	
Instance on 1st Floor	Does not Exist
<b>Walls</b>	
Instance on 1st Floor	Inspected



**NYC Department of Education  
Building Condition Assessment Survey 2023 - 2024**

Architectural Inspection



K219

Question	Response
<b>INTERIOR</b>	
<b>CAFETERIA</b>	
<b>Walls</b>	
Condition	2 - Between Good and Fair
Deficiency	SALT GLAZED BRICK: CRACKS/SPALLING
Deficiency Location/Instance	Near Windows
Deficiency Quantity	70
Quantity Uom	S.F.
Potential Action	REPLACE
Urgency of Action	PRIORITY 3
Purpose of Action	LEVEL 2
Deficiency Photo1	
	Near Windows
Violations	No violations recorded.
<b>Window Curtains/Shades/Blinds</b>	
Instance on 1st Floor	Does not Exist
<b>CLASSROOMS/CORRIDORS/ADMIN SPACES</b>	
<b>Ceiling</b>	Inspected
Condition	2 - Between Good and Fair
Deficiency	PLASTER: CRACKS/SPALLING
Deficiency Location/Instance	Room 312
Deficiency Quantity	20
Quantity Uom	S.F.
Potential Action	REPLACE
Urgency of Action	PRIORITY 3
Purpose of Action	LEVEL 2
Deficiency Photo1	
	Room 312
Violations	No violations recorded.
<b>Door(s)</b>	
<b>Condition</b>	Inspected
Condition	5 - Poor
Deficiency	WOOD: DETERIORATED DOOR
Deficiency Location/Instance	Rooms 459, 417, 409, 408, 405 and others
Deficiency Quantity	7

**NYC Department of Education  
Building Condition Assessment Survey 2023 - 2024**

Architectural Inspection

**K219**

Question	Response
<b>INTERIOR</b>	
<b>CLASSROOMS/CORRIDORS/ADMIN SPACES</b>	
<b>Door(s)</b>	
Quantity Uom	EACH
Potential Action	MAINTENANCE
Urgency of Action	PRIORITY 3
Purpose of Action	LEVEL 2
Deficiency Photo1	
	Room 417
Violations	No violations recorded.
<b>Floor Finish</b>	Inspected
Condition	3 - Fair
Deficiency	CARPET: WORN/DETERIORATED
Deficiency Location/Instance	Room 218
Deficiency Quantity	200
Quantity Uom	S.F.
Potential Action	REPLACE
Urgency of Action	PRIORITY 3
Purpose of Action	LEVEL 2
Deficiency Photo1	
	Room 218
Violations	No violations recorded.
Deficiency	CONCRETE: CRACKS
Deficiency Location/Instance	Corridor near 3rd Floor - Gymnasium
Deficiency Quantity	20
Quantity Uom	S.F.
Potential Action	REPLACE
Urgency of Action	PRIORITY 3
Purpose of Action	LEVEL 2

**NYC Department of Education  
Building Condition Assessment Survey 2023 - 2024**

Architectural Inspection

K219

**Question**

**Response**

**INTERIOR**

**CLASSROOMS/CORRIDORS/ADMIN SPACES**

**Floor Finish**

Deficiency Photo1



Corridor near 3rd Floor - Gymnasium

No violations recorded.

Violations

Deficiency

VINYL TILES: DETERIORATED SUBSTRATE

Deficiency Location/Instance

Room 413

Deficiency Quantity

80

Quantity Uom

S.F.

Potential Action

REPLACE

Urgency of Action

PRIORITY 5

Purpose of Action

LEVEL 6

Deficiency Photo1

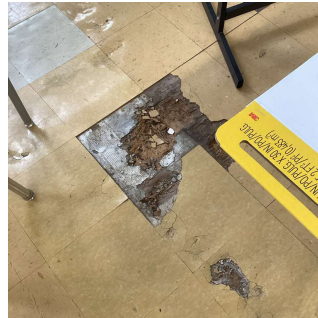

Room 413

No violations recorded.

Violations

Deficiency

VINYL TILES: TRIPPING HAZARD - ELECTRICAL OUTLET

Deficiency Location/Instance

Room 302

Deficiency Quantity

30

Quantity Uom

S.F.

Potential Action

REMOVE

Urgency of Action

PRIORITY 5

Purpose of Action

LEVEL 6

Deficiency Photo1

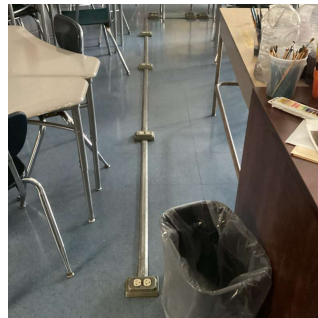

Room 302

No violations recorded.

Violations

**NYC Department of Education  
Building Condition Assessment Survey 2023 - 2024**

Architectural Inspection

**K219**

Question	Response
----------	----------

**INTERIOR**

**CLASSROOMS/CORRIDORS/ADMIN SPACES**

**Floor Finish**

Deficiency	VINYL TILES: DETERIORATED SUBSTRATE
Deficiency Location/Instance	Rooms 416, 413, 409, 307, 306 and others
Deficiency Quantity	3,000
Quantity Uom	S.F.
Potential Action	REPLACE
Urgency of Action	PRIORITY 3
Purpose of Action	LEVEL 2
Deficiency Photo1	



Room 413

Violations	No violations recorded.
------------	-------------------------

Deficiency	VINYL TILES: BROKEN/DETERIORATED/MISSING TILES
Deficiency Location/Instance	Rooms 417, 315, 311, 203, 106 and others
Deficiency Quantity	300
Quantity Uom	S.F.
Potential Action	REPLACE
Urgency of Action	PRIORITY 3
Purpose of Action	LEVEL 2
Deficiency Photo1	



Room 417

Violations	No violations recorded.
------------	-------------------------



Deficiency	TERRAZZO: CRACKS
Deficiency Location/Instance	Corridor near Rooms 157, 153, 110, 109, by Stair E/1 and others
Deficiency Quantity	100
Quantity Uom	S.F.
Potential Action	REPLACE
Urgency of Action	PRIORITY 3
Purpose of Action	LEVEL 2



**NYC Department of Education  
Building Condition Assessment Survey 2023 - 2024**

Architectural Inspection

**K219**

Question	Response
<b>INTERIOR</b>	
<b>CLASSROOMS/CORRIDORS/ADMIN SPACES</b>	
<b>Walls</b>	
Deficiency Photo1           Violations	  Corridor near Stair A/1  No violations recorded.
Deficiency Deficiency Location/Instance Deficiency Quantity Quantity Uom Potential Action Urgency of Action Purpose of Action Deficiency Photo1           Violations	STONE: CRACKS/SPALLING Exit 9 - Vestibule 10 S.F. REPLACE PRIORITY 3 LEVEL 2    Exit 9 - Vestibule  No violations recorded.
<b>Specialties</b>	Inspected
<b>Classroom Locker(s)</b>	Inspected
Condition Deficiency Deficiency Location/Instance Deficiency Quantity Quantity Uom Potential Action Urgency of Action Purpose of Action	2 - Between Good and Fair DAMAGED UNITS Locker 004 (Corridor near Room 153) 1 EACH REPLACE PRIORITY 3 LEVEL 2

**NYC Department of Education  
Building Condition Assessment Survey 2023 - 2024**

Architectural Inspection

**K219**

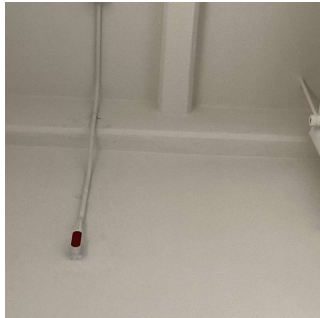
Question	Response
<b>INTERIOR</b>	
<b>CLASSROOMS/CORRIDORS/ADMIN SPACES</b>	
<b>Specialties</b>	
<b>Classroom Locker(s)</b>	Inspected
Deficiency Photo1	
	Locker 004 (Corridor near Room 153)
Violations	No violations recorded.
<b>Fixed Seating</b>	Does not Exist
<b>GYMNASIUM</b>	
Instance on 3rd Floor	Inspected
Instance on 4th Floor	Inspected
<b>Ceiling</b>	
Instance on 3rd Floor	Inspected
Condition	2 - Between Good and Fair
Deficiency	PLASTER: CRACKS/SPALLING
Deficiency Location/Instance	Office Room
Deficiency Quantity	10
Quantity Uom	S.F.
Potential Action	REPLACE
Urgency of Action	PRIORITY 3
Purpose of Action	LEVEL 2
Deficiency Photo1	
	Office Room
Violations	No violations recorded.
Instance on 4th Floor	Inspected
Condition	2 - Between Good and Fair
Deficiency	PLASTER: CRACKS/SPALLING
Deficiency Location/Instance	Office Room
Deficiency Quantity	10
Quantity Uom	S.F.
Potential Action	REPLACE
Urgency of Action	PRIORITY 3
Purpose of Action	LEVEL 2

**NYC Department of Education  
Building Condition Assessment Survey 2023 - 2024**

Architectural Inspection

**K219**

Question	Response
----------	----------

**INTERIOR**

**GYMNASIUM**

**Ceiling**

Deficiency Photo1



Office Room

Violations

No violations recorded.

**Door(s)**

Instance on 3rd Floor	Inspected
Condition	5 - Poor
Deficiency	WOOD: DETERIORATED DOOR
Deficiency Location/Instance	Room 362
Deficiency Quantity	1
Quantity Uom	EACH
Potential Action	MAINTENANCE
Urgency of Action	PRIORITY 3
Purpose of Action	LEVEL 2
Deficiency Photo1	



Room 362

Violations

No violations recorded.

Instance on 4th Floor	Inspected
Condition	5 - Poor
Deficiency	WOOD: DETERIORATED DOOR AND FRAME
Deficiency Location/Instance	Main Entrance
Deficiency Quantity	2
Quantity Uom	EACH
Potential Action	MAINTENANCE
Urgency of Action	PRIORITY 3
Purpose of Action	LEVEL 2



**NYC Department of Education  
Building Condition Assessment Survey 2023 - 2024**

Architectural Inspection

K219

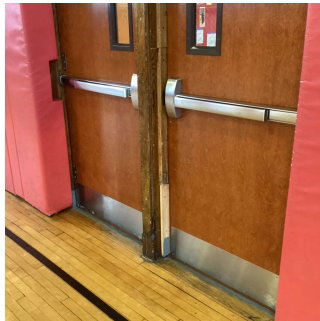
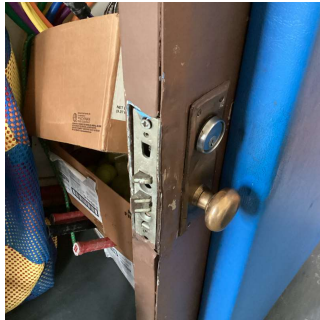
Question	Response
<b>INTERIOR</b>	
<b>GYMNASIUM</b>	
<b>Door(s)</b>	
Deficiency Photo1	
	Main Entrance
Violations	No violations recorded.
Instance on 3rd Floor	Inspected
Condition	5 - Poor
Deficiency	METAL: DETERIORATED DOOR
Deficiency Location/Instance	Room 361
Deficiency Quantity	1
Quantity Uom	EACH
Potential Action	MAINTENANCE
Urgency of Action	PRIORITY 3
Purpose of Action	LEVEL 2
Deficiency Photo1	
	Room 361
Violations	No violations recorded.
Instance on 4th Floor	Inspected
Condition	5 - Poor
Deficiency	WOOD: DETERIORATED DOOR
Deficiency Location/Instance	Office Room
Deficiency Quantity	1
Quantity Uom	EACH
Potential Action	MAINTENANCE
Urgency of Action	PRIORITY 3
Purpose of Action	LEVEL 2

**NYC Department of Education  
Building Condition Assessment Survey 2023 - 2024**

Architectural Inspection

K219

Question	Response
<b>INTERIOR</b>	
<b>GYMNASIUM</b>	
<b>Door(s)</b>	
Deficiency Photo1	
	Office Room
Violations	No violations recorded.
Instance on 3rd Floor	Inspected
Condition	5 - Poor
Deficiency	WOOD: DETERIORATED DOOR AND FRAME
Deficiency Location/Instance	Office Room
Deficiency Quantity	1
Quantity Uom	EACH
Potential Action	MAINTENANCE
Urgency of Action	PRIORITY 3
Purpose of Action	LEVEL 2
Deficiency Photo1	
	Office Room
Violations	No violations recorded.
<b>Fixed Equipment</b>	
Instance on 4th Floor	Inspected
Condition	2 - Between Good and Fair
Deficiency	No deficiencies recorded
Instance on 3rd Floor	Inspected
Condition	2 - Between Good and Fair
Deficiency	No deficiencies recorded
<b>Floor Finish</b>	
Instance on 3rd Floor	Inspected
Condition	2 - Between Good and Fair
Deficiency	CONCRETE: CRACKS
Deficiency Location/Instance	Office Room
Deficiency Quantity	10
Quantity Uom	S.F.
Potential Action	REPLACE
Urgency of Action	PRIORITY 3

**NYC Department of Education  
Building Condition Assessment Survey 2023 - 2024**

Architectural Inspection

**K219**

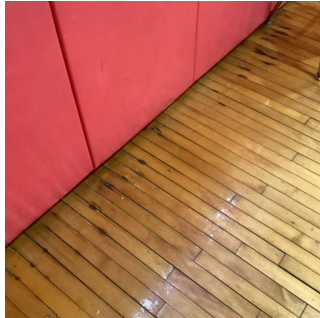
Question	Response
<b>INTERIOR</b>	
<b>GYMNASIUM</b>	
<b>Floor Finish</b>	
Purpose of Action	LEVEL 2
Deficiency Photo1	
	Office Room
Violations	No violations recorded.
Instance on 4th Floor	Inspected
Condition	2 - Between Good and Fair
Deficiency	WOOD: DAMAGED/DETERIORATED
Deficiency Location/Instance	Near Right Side Windows
Deficiency Quantity	20
Quantity Uom	S.F.
Potential Action	REPLACE
Urgency of Action	PRIORITY 3
Purpose of Action	LEVEL 2
Deficiency Photo1	
	Near Right Side Windows
Violations	No violations recorded.
Deficiency	VINYL TILES: BROKEN/DETERIORATED/MISSING TILES
Deficiency Location/Instance	Office Room
Deficiency Quantity	20
Quantity Uom	S.F.
Potential Action	REPLACE
Urgency of Action	PRIORITY 3
Purpose of Action	LEVEL 2

**NYC Department of Education  
Building Condition Assessment Survey 2023 - 2024**

Architectural Inspection

**K219**

Question	Response
----------	----------

**INTERIOR**

**GYMNASIUM**

**Floor Finish**

Deficiency Photo1



Office Room

No violations recorded.

Violations

**Seating**

Instance on 4th Floor	Inspected
Condition	3 - Fair
Deficiency	DAMAGED FIXED SEATING
Deficiency Location/Instance	Near Left Side Windows
Deficiency Quantity	1
Quantity Uom	EACH
Potential Action	REPLACE
Urgency of Action	PRIORITY 3
Purpose of Action	LEVEL 2
Deficiency Photo1	

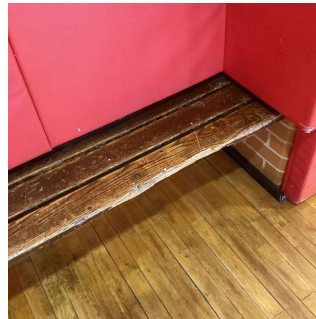

Near Left Side Windows

No violations recorded.

Violations

Instance on 3rd Floor	Inspected
Condition	5 - Poor
Deficiency	DAMAGED FIXED SEATING
Deficiency Location/Instance	Near Right and Left Side Windows
Deficiency Quantity	8
Quantity Uom	EACH
Potential Action	REPLACE
Urgency of Action	PRIORITY 3
Purpose of Action	LEVEL 2

**NYC Department of Education  
Building Condition Assessment Survey 2023 - 2024**

Architectural Inspection

K219

Question	Response
<b>INTERIOR</b>	
<b>GYMNASIUM</b>	
<b>Seating</b>	
Deficiency Photo1	
Violations	Near Right Side Windows No violations recorded.
<b>Sliding-folding Partition</b>	
Instance on 3rd Floor	Does not Exist
Instance on 4th Floor	Does not Exist
<b>Stage</b>	
Instance on 4th Floor	Does not Exist
Instance on 3rd Floor	Does not Exist
<b>Walls</b>	
Instance on 3rd Floor	Inspected
Condition	2 - Between Good and Fair
Deficiency	WALL PADDING: DETERIORATED
Deficiency Location/Instance	Near Left Side Windows
Deficiency Quantity	40
Quantity Uom	S.F.
Potential Action	REPLACE
Urgency of Action	PRIORITY 3
Purpose of Action	LEVEL 2
Deficiency Photo1	
Violations	Near Left Side Windows No violations recorded.
Deficiency	PLASTER: CRACKS/SPALLING
Deficiency Location/Instance	Office Room
Deficiency Quantity	20
Quantity Uom	S.F.
Potential Action	REPLACE
Urgency of Action	PRIORITY 3
Purpose of Action	LEVEL 2

**NYC Department of Education  
Building Condition Assessment Survey 2023 - 2024**

Architectural Inspection

K219

Question	Response
----------	----------

**INTERIOR**

**GYMNASIUM**

**Walls**

Deficiency Photo1

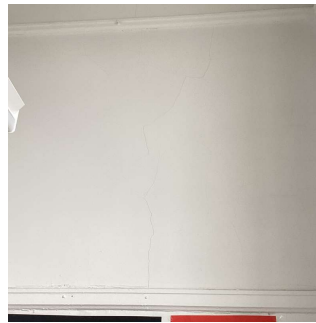

Office Room

Violations

No violations recorded.

Instance on 4th Floor

Inspected

Condition

3 - Fair

Deficiency

PLASTER: CRACKS/SPALLING

Deficiency Location/Instance

Office Room

Deficiency Quantity

20

Quantity Uom

S.F.

Potential Action

REPLACE

Urgency of Action

PRIORITY 3

Purpose of Action

LEVEL 2

Deficiency Photo1

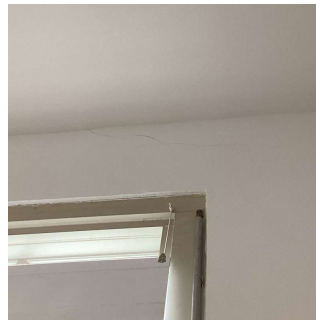

Office Room

Violations

No violations recorded.

Deficiency

WALL PADDING: DETERIORATED

Deficiency Location/Instance

By Main Entrance, Near Right and Left Side Windows, next to Stair F

Deficiency Quantity

180

Quantity Uom

S.F.

Potential Action

REPLACE

Urgency of Action

PRIORITY 3

Purpose of Action

LEVEL 2



Deficiency Photo1



**NYC Department of Education  
Building Condition Assessment Survey 2023 - 2024**

Architectural Inspection



**K219**

Question	Response
<b>INTERIOR</b>	
<b>GYMNASIUM</b>	
<b>Walls</b>	
Violations	Near Left Side Windows No violations recorded.
Instance on 3rd Floor	Inspected
Condition	2 - Between Good and Fair
Deficiency	SALT GLAZED BRICK: CRACKS/SPALLING
Deficiency Location/Instance	Near Right and Left Side Windows
Deficiency Quantity	40
Quantity Uom	S.F.
Potential Action	REPLACE
Urgency of Action	PRIORITY 3
Purpose of Action	LEVEL 2
Deficiency Photo1	
Violations	Near Right Side Windows No violations recorded.
Instance on 4th Floor	Inspected
Condition	3 - Fair
Deficiency	SALT GLAZED BRICK: CRACKS/SPALLING
Deficiency Location/Instance	Near Left Side Windows, by Main Entrance
Deficiency Quantity	30
Quantity Uom	S.F.
Potential Action	REPLACE
Urgency of Action	PRIORITY 3
Purpose of Action	LEVEL 2
Deficiency Photo1	
Violations	Near Left Side Windows No violations recorded.
<b>Window Curtains/Shades/Blinds</b>	
Instance on 3rd Floor	Does not Exist
Instance on 4th Floor	Does not Exist
<b>INTERIOR DOOR HARDWARE</b>	Inspected

**NYC Department of Education  
Building Condition Assessment Survey 2023 - 2024**

Architectural Inspection

**K219**



<b>Question</b>	<b>Response</b>
<b>INTERIOR</b>	
<b>INTERIOR DOOR HARDWARE</b>	Inspected
Condition	3 - Fair
Deficiency	No deficiencies recorded
<b>INTERIOR GUARDS</b>	Inspected
Condition	2 - Between Good and Fair
Deficiency	DETERIORATED/TORN-OUT/MISSING
Deficiency Location/Instance	Stairs E/Bulkhead, F/Bulkhead
Deficiency Quantity	40
Quantity Uom	S.F.
Potential Action	REPLACE
Urgency of Action	PRIORITY 3
Purpose of Action	LEVEL 2
Deficiency Photo1	
Stair E/Bulkhead	
Violations	No violations recorded.
<b>KITCHEN</b>	Inspected
Instance on 1st Floor	Inspected
<b>Ceiling</b>	
Instance on 1st Floor	Inspected
Condition	2 - Between Good and Fair
Deficiency	PLASTER: CRACKS/SPALLING
Deficiency Location/Instance	Near Windows
Deficiency Quantity	10
Quantity Uom	S.F.
Potential Action	REPLACE
Urgency of Action	PRIORITY 3
Purpose of Action	LEVEL 2
Deficiency Photo1	
Near Windows	
Violations	No violations recorded.
<b>Door(s)</b>	
Instance on 1st Floor	Inspected
Condition	5 - Poor



**NYC Department of Education  
Building Condition Assessment Survey 2023 - 2024**

Architectural Inspection

**K219**

Question	Response
<b>INTERIOR</b>	
<b>KITCHEN</b>	
<b>Door(s)</b>	
Deficiency	METAL: DETERIORATED DOOR
Deficiency Location/Instance	Kitchen Locker Room
Deficiency Quantity	1
Quantity Uom	EACH
Potential Action	MAINTENANCE
Urgency of Action	PRIORITY 3
Purpose of Action	LEVEL 2
Deficiency Photo1	
Violations	Kitchen Locker Room No violations recorded.
Deficiency	WOOD: DETERIORATED DOOR
Deficiency Location/Instance	Office Room Closet
Deficiency Quantity	1
Quantity Uom	EACH
Potential Action	MAINTENANCE
Urgency of Action	PRIORITY 3
Purpose of Action	LEVEL 2
Deficiency Photo1	
Violations	Office Room Closet No violations recorded.
Deficiency	METAL CLAD WOOD: DETERIORATED DOOR
Deficiency Location/Instance	Office Room
Deficiency Quantity	1
Quantity Uom	EACH
Potential Action	MAINTENANCE
Urgency of Action	PRIORITY 3
Purpose of Action	LEVEL 2

**NYC Department of Education  
Building Condition Assessment Survey 2023 - 2024**

Architectural Inspection

K219

Question	Response
<b>INTERIOR</b>	
<b>KITCHEN</b>	

**Door(s)**

Deficiency Photo1



Office Room

Violations

No violations recorded.

Deficiency

WOOD: MISSING DOOR

Deficiency Location/Instance

Preparation Area

Deficiency Quantity

3

Quantity Uom

EACH

Potential Action

MAINTENANCE

Urgency of Action

PRIORITY 3

Purpose of Action

LEVEL 2

Deficiency Photo1

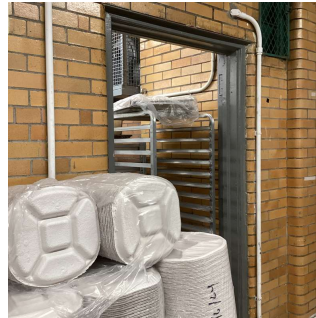

Preparation Area

Violations

No violations recorded.

**Floor Finish**

Instance on 1st Floor

Inspected

Condition

3 - Fair

Deficiency

VINYL TILES: BROKEN/DETERIORATED/MISSING TILES

Deficiency Location/Instance

Servery, Near Office Room, Kitchen Locker Room

Deficiency Quantity

40

Quantity Uom

S.F.

Potential Action

REPLACE

Urgency of Action

PRIORITY 3

Purpose of Action

LEVEL 2

**NYC Department of Education  
Building Condition Assessment Survey 2023 - 2024**

Architectural Inspection

**K219**

**Question**

**Response**

**INTERIOR**

**KITCHEN**

**Floor Finish**

Deficiency Photo1

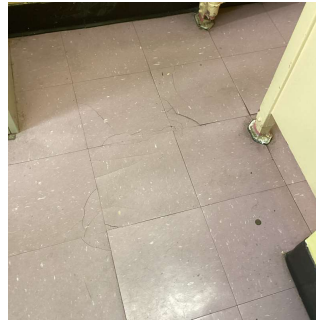

Kitchen Locker Room

No violations recorded.

Violations

Deficiency

CONCRETE: CRACKS

Deficiency Location/Instance

Near Sink

Deficiency Quantity

10

Quantity Uom

S.F.

Potential Action

REPLACE

Urgency of Action

PRIORITY 3

Purpose of Action

LEVEL 2

Deficiency Photo1



Near Sink

No violations recorded.

Violations

**Walls**

Instance on 1st Floor

Inspected

Condition

2 - Between Good and Fair

Deficiency

SALT GLAZED BRICK: CRACKS/SPALLING

Deficiency Location/Instance

Office Room

Deficiency Quantity

20

Quantity Uom

S.F.

Potential Action

REPLACE

Urgency of Action

PRIORITY 3

Purpose of Action

LEVEL 2

**NYC Department of Education  
Building Condition Assessment Survey 2023 - 2024**

Architectural Inspection

**K219**

**Question**

**Response**

**INTERIOR**

**KITCHEN**

**Walls**

Deficiency Photo1



Office Room

Violations

No violations recorded.

Deficiency

PLASTER: CRACKS/SPALLING

Deficiency Location/Instance

Servery

Deficiency Quantity

10

Quantity Uom

S.F.

Potential Action

REPLACE

Urgency of Action

PRIORITY 3

Purpose of Action

LEVEL 2

Deficiency Photo1

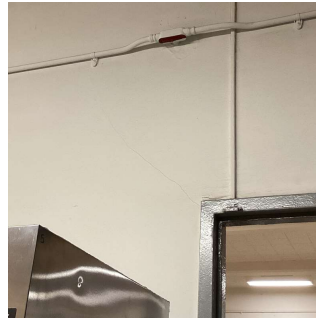

Servery

Violations

No violations recorded.

Deficiency

CERAMIC TILE: BROKEN/ MISSING

Deficiency Location/Instance

Preparation Area

Deficiency Quantity

10

Quantity Uom

S.F.

Potential Action

REPLACE

Urgency of Action

PRIORITY 3

Purpose of Action

LEVEL 2

Deficiency Photo1



Preparation Area



Violations

No violations recorded.

**NYC Department of Education**  
**Building Condition Assessment Survey 2023 - 2024**

Architectural Inspection

K219

Question	Response
<b>INTERIOR</b>	
<b>LIBRARY</b>	Does not Exist
<b>LOCKER ROOM</b>	Inspected
Instance on 4th Floor	Inspected
Alternative use	Yes
<b>Ceiling</b>	
Instance on 4th Floor	Inspected
Condition	2 - Between Good and Fair
Deficiency	PLASTER: CRACKS/SPALLING
Deficiency Location/Instance	Near Windows
Deficiency Quantity	10
Quantity Uom	S.F.
Potential Action	REPLACE
Urgency of Action	PRIORITY 3
Purpose of Action	LEVEL 2
Deficiency Photo1	
Violations	Near Windows No violations recorded.
<b>Door(s)</b>	
Instance on 4th Floor	Inspected
Condition	3 - Fair
Deficiency	METAL CLAD WOOD: DETERIORATED DOOR
Deficiency Location/Instance	Main Entrance
Deficiency Quantity	1
Quantity Uom	EACH
Potential Action	MAINTENANCE
Urgency of Action	PRIORITY 3
Purpose of Action	LEVEL 2
Deficiency Photo1	
Violations	Main Entrance No violations recorded.
<b>Floor Finish</b>	
Instance on 4th Floor	Inspected
Condition	2 - Between Good and Fair

**NYC Department of Education**  
**Building Condition Assessment Survey 2023 - 2024**

Architectural Inspection



K219

Question	Response
<b>INTERIOR</b>	
<b>LOCKER ROOM</b>	
<b>Floor Finish</b>	
Deficiency	No deficiencies recorded
<b>Locker Room Lockers</b>	
Instance on 4th Floor	Does not Exist
<b>Walls</b>	
Instance on 4th Floor	Inspected
Condition	2 - Between Good and Fair
Deficiency	CERAMIC TILE: BROKEN/ MISSING
Deficiency Location/Instance	Near Shower Room
Deficiency Quantity	10
Quantity Uom	S.F.
Potential Action	REPLACE
Urgency of Action	PRIORITY 3
Purpose of Action	LEVEL 2
Deficiency Photo1	
	Near Shower Room
Violations	No violations recorded.
Deficiency	PLASTER: CRACKS/SPALLING
Deficiency Location/Instance	Near Shower Room, by Windows
Deficiency Quantity	20
Quantity Uom	S.F.
Potential Action	REPLACE
Urgency of Action	PRIORITY 3
Purpose of Action	LEVEL 2
Deficiency Photo1	
	Near Shower Room
Violations	No violations recorded.
<b>MULTI-PURPOSE ROOM</b>	Does not Exist
<b>SCIENCE DEMO ROOM</b>	Does not Exist
<b>SCIENCE LAB</b>	Does not Exist
<b>SCIENCE PREP ROOM</b>	Does not Exist

**NYC Department of Education**  
**Building Condition Assessment Survey 2023 - 2024**

Architectural Inspection

**K219**

<b>Question</b>	<b>Response</b>
<b>INTERIOR</b>	
<b>SHOWER ROOM</b>	Inspected
Instance on 4th Floor	Inaccessible
<b>STAIRS/RAMPS: INTERIOR</b>	Inspected
Do Letter Stair Signs Exist?	Yes
<b>Ceiling</b>	Inspected
Condition	2 - Between Good and Fair
Deficiency	PLASTER: CRACKS/SPALLING
Deficiency Location/Instance	Stair A/4
Deficiency Quantity	10
Quantity Uom	S.F.
Potential Action	REPLACE
Urgency of Action	PRIORITY 3
Purpose of Action	LEVEL 2
Deficiency Photo1	
Violations	Stair A/4 No violations recorded.
<b>Door(s)</b>	Inspected
Condition	5 - Poor
Deficiency	WOOD: DETERIORATED DOOR
Deficiency Location/Instance	Exit 6 - Vestibule
Deficiency Quantity	2
Quantity Uom	EACH
Potential Action	MAINTENANCE
Urgency of Action	PRIORITY 3
Purpose of Action	LEVEL 2
Deficiency Photo1	
Violations	Exit 6 - Vestibule No violations recorded.
Deficiency	METAL: DETERIORATED DOOR AND FRAME
Deficiency Location/Instance	Stairs E/1, 4
Deficiency Quantity	4
Quantity Uom	EACH
Potential Action	MAINTENANCE

**NYC Department of Education  
Building Condition Assessment Survey 2023 - 2024**

Architectural Inspection

**K219**

Question	Response
<b>INTERIOR</b>	
<b>STAIRS/RAMPS: INTERIOR</b>	
<b>Door(s)</b>	
Urgency of Action	PRIORITY 3
Purpose of Action	LEVEL 2
Deficiency Photo1	
Violations	Stair E/1 No violations recorded.
<b>Partition</b>	Does not Exist
<b>Railings</b>	Inspected
Condition	3 - Fair
Deficiency	METAL: MISSING
Deficiency Location/Instance	Stair F/Bulkhead
Deficiency Quantity	10
Quantity Uom	L.F.
Potential Action	REPLACE
Urgency of Action	PRIORITY 5
Purpose of Action	LEVEL 6
Deficiency Photo1	
Violations	Stair F/Bulkhead No violations recorded.
<b>Stairs and Landings</b>	Inspected
Condition	3 - Fair
Deficiency	STONE: WORN-OUT TREAD/NOSINGS
Deficiency Location/Instance	Stair A/1
Deficiency Quantity	140
Quantity Uom	S.F.
Potential Action	REPLACE
Urgency of Action	PRIORITY 3
Purpose of Action	LEVEL 2



**NYC Department of Education  
Building Condition Assessment Survey 2023 - 2024**

Architectural Inspection

K219

Question	Response
----------	----------

**INTERIOR**

**STAIRS/RAMPS: INTERIOR**

**Stairs and Landings**

Deficiency Photo1

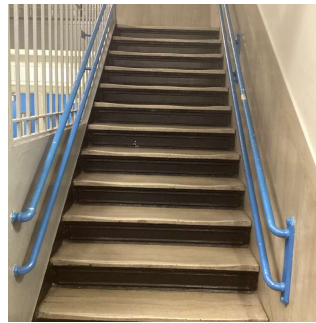

Stair A/1

Violations

No violations recorded.

Deficiency

CONCRETE: CRACKS/SPALLING - MAJOR

Deficiency Location/Instance

Stair E/Bulkhead, Exit 6 - Vestibule

Deficiency Quantity

50

Quantity Uom

S.F.

Potential Action

REPLACE

Urgency of Action

PRIORITY 3

Purpose of Action

LEVEL 2

Deficiency Photo1



Stair E/Bulkhead

Violations

No violations recorded.

**Walls**

Inspected

Condition

2 - Between Good and Fair

Deficiency

PLASTER: CRACKS/SPALLING

Deficiency Location/Instance

Stairs E/3, 4

Deficiency Quantity

20

Quantity Uom

S.F.

Potential Action

REPLACE

Urgency of Action

PRIORITY 3

Purpose of Action

LEVEL 2



Deficiency Photo1



**NYC Department of Education  
Building Condition Assessment Survey 2023 - 2024**

Architectural Inspection

**K219**

Question	Response
<b>INTERIOR</b>	
<b>STAIRS/RAMPS: INTERIOR</b>	
<b>Walls</b>	
Violations	Stair E/3 No violations recorded.
Deficiency	STONE MOLDINGS: CRACKS/SPALLING
Deficiency Location/Instance	Stair A/1
Deficiency Quantity	30
Quantity Uom	L.F.
Potential Action	REPLACE
Urgency of Action	PRIORITY 3
Purpose of Action	LEVEL 2
Deficiency Photo1	
Violations	Stair A/1 No violations recorded.
Deficiency	PLASTER: CRACKS/SPALLING - ACTIVE LEAK
Deficiency Location/Instance	Stair E/3
Deficiency Quantity	20
Quantity Uom	S.F.
Potential Action	REPLACE
Urgency of Action	PRIORITY 5
Purpose of Action	LEVEL 2
Deficiency Photo1	
Violations	Stair E/3 No violations recorded.
Deficiency	STONE: CRACKS/SPALLING
Deficiency Location/Instance	Stair A/1
Deficiency Quantity	30
Quantity Uom	S.F.
Potential Action	REPLACE
Urgency of Action	PRIORITY 3
Purpose of Action	LEVEL 2

**NYC Department of Education  
Building Condition Assessment Survey 2023 - 2024**

Architectural Inspection

**K219**

Question	Response
<b>INTERIOR</b>	
<b>STAIRS/RAMPS: INTERIOR</b>	
<b>Walls</b>	
Deficiency Photo1	
Violations	Stair A/1 No violations recorded.
<b>TOILET ROOMS - STAFF</b>	Inspected
<b>Ceiling</b>	Inspected
Condition	2 - Between Good and Fair
Deficiency	No deficiencies recorded
<b>Door(s)</b>	Inspected
Condition	5 - Poor
Deficiency	WOOD: DETERIORATED DOOR
Deficiency Location/Instance	Rooms 356, 257, 150
Deficiency Quantity	3
Quantity Uom	EACH
Potential Action	MAINTENANCE
Urgency of Action	PRIORITY 3
Purpose of Action	LEVEL 2
Deficiency Photo1	
Violations	Room 150 No violations recorded.
<b>Floor Finish</b>	Inspected
Condition	3 - Fair
Deficiency	VINYL TILES: BROKEN/DETERIORATED/MISSING TILES
Deficiency Location/Instance	In Kitchen Locker Room
Deficiency Quantity	10
Quantity Uom	S.F.
Potential Action	REPLACE
Urgency of Action	PRIORITY 3
Purpose of Action	LEVEL 2

**NYC Department of Education  
Building Condition Assessment Survey 2023 - 2024**

Architectural Inspection

K219

Question	Response
----------	----------

**INTERIOR**

**TOILET ROOMS - STAFF**

**Floor Finish**

Deficiency Photo1

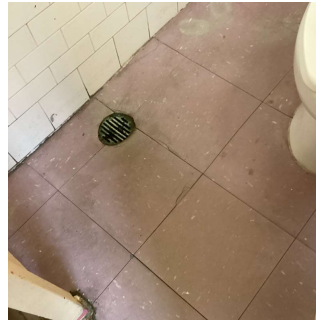

In Kitchen Locker Room

Violations

No violations recorded.

Deficiency

CERAMIC TILE: BROKEN/MISSING TILES

Deficiency Location/Instance

Room 450

Deficiency Quantity

10

Quantity Uom

S.F.

Potential Action

REPLACE

Urgency of Action

PRIORITY 3

Purpose of Action

LEVEL 2

Deficiency Photo1



Room 450

Violations

No violations recorded.

**Stalls**

Inspected

Condition

5 - Poor

Deficiency

RUST - MAJOR

Deficiency Location/Instance

Rooms 150, 257, 356, In Kitchen Locker Room

Deficiency Quantity

4

Quantity Uom

EACH

Potential Action

REPLACE

Urgency of Action

PRIORITY 3

Purpose of Action

LEVEL 2

Deficiency Photo1

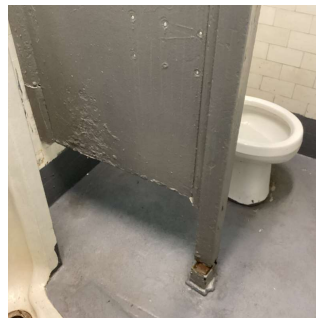

**NYC Department of Education  
Building Condition Assessment Survey 2023 - 2024**

Architectural Inspection

**K219**

Question	Response
<b>INTERIOR</b>	
<b>TOILET ROOMS - STAFF</b>	
<b>Stalls</b>	Inspected
	Room 150
Violations	No violations recorded.
<b>Walls</b>	Inspected
Condition	2 - Between Good and Fair
Deficiency	PLASTER: CRACKS/SPALLING
Deficiency Location/Instance	Room 450
Deficiency Quantity	10
Quantity Uom	S.F.
Potential Action	REPLACE
Urgency of Action	PRIORITY 3
Purpose of Action	LEVEL 2
Deficiency Photo1	
	Room 450
Violations	No violations recorded.
Deficiency	CERAMIC TILE: BROKEN/ MISSING
Deficiency Location/Instance	Room 150
Deficiency Quantity	10
Quantity Uom	S.F.
Potential Action	REPLACE
Urgency of Action	PRIORITY 3
Purpose of Action	LEVEL 2
Deficiency Photo1	
	Room 150
Violations	No violations recorded.
<b>TOILET ROOMS - STUDENTS</b>	
	Inspected
<b>Ceiling</b>	Inspected
Condition	2 - Between Good and Fair
Deficiency	PLASTER: CRACKS/SPALLING
Deficiency Location/Instance	Room 356
Deficiency Quantity	10

**NYC Department of Education  
Building Condition Assessment Survey 2023 - 2024**

Architectural Inspection

**K219**

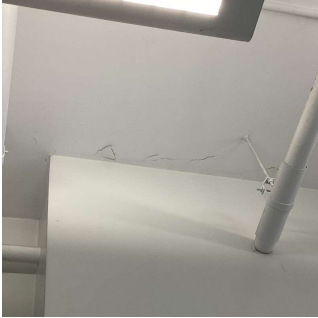
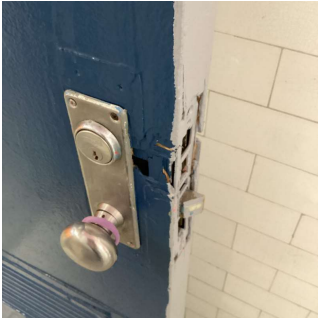
Question	Response
<b>INTERIOR</b>	
<b>TOILET ROOMS - STUDENTS</b>	
<b>Ceiling</b>	
Quantity Uom	S.F.
Potential Action	REPLACE
Urgency of Action	PRIORITY 3
Purpose of Action	LEVEL 2
Deficiency Photo1	
	Room 356
Violations	No violations recorded.
<b>Door(s)</b>	Inspected
Condition	5 - Poor
Deficiency	WOOD: DETERIORATED DOOR
Deficiency Location/Instance	Rooms 456, 255, 152, In Room 204
Deficiency Quantity	4
Quantity Uom	EACH
Potential Action	MAINTENANCE
Urgency of Action	PRIORITY 3
Purpose of Action	LEVEL 2
Deficiency Photo1	
	Room 456
Violations	No violations recorded.
<b>Floor Finish</b>	Inspected
Condition	2 - Between Good and Fair
Deficiency	CERAMIC TILE: BROKEN/MISSING TILES
Deficiency Location/Instance	Rooms 153, 456
Deficiency Quantity	20
Quantity Uom	S.F.
Potential Action	REPLACE
Urgency of Action	PRIORITY 3
Purpose of Action	LEVEL 2

**NYC Department of Education  
Building Condition Assessment Survey 2023 - 2024**

Architectural Inspection

**K219**

Question	Response
----------	----------

**INTERIOR**

**TOILET ROOMS - STUDENTS**

**Floor Finish**

Deficiency Photo1



Room 456

Violations

No violations recorded.

**Stalls**

Inspected

Condition

3 - Fair

Deficiency

BROKEN/MISSING

Deficiency Location/Instance

Rooms 153, 356

Deficiency Quantity

2

Quantity Uom

EACH

Potential Action

REPLACE

Urgency of Action

PRIORITY 3

Purpose of Action

LEVEL 2

Deficiency Photo1

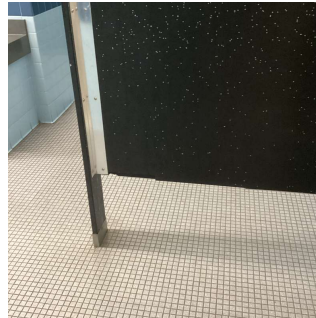

Room 153

Violations

No violations recorded.

**Walls**

Inspected

Condition

2 - Between Good and Fair

Deficiency

PLASTER: CRACKS/SPALLING

Deficiency Location/Instance

Rooms 450, 356, In Room 204

Deficiency Quantity

30

Quantity Uom

S.F.

Potential Action

REPLACE

Urgency of Action

PRIORITY 3

Purpose of Action

LEVEL 2

**NYC Department of Education  
Building Condition Assessment Survey 2023 - 2024**

Architectural Inspection

K219

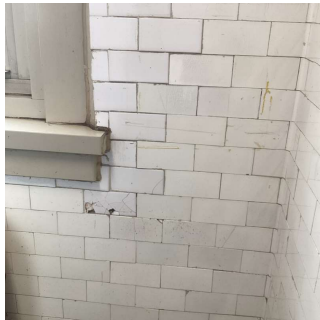
Question	Response
<b>INTERIOR</b>	
<b>TOILET ROOMS - STUDENTS</b>	
<b>Walls</b>	
Deficiency Photo1	
Violations	Room 450 No violations recorded.
Deficiency	CERAMIC TILE: BROKEN/ MISSING
Deficiency Location/Instance	Room 450
Deficiency Quantity	10
Quantity Uom	S.F.
Potential Action	REPLACE
Urgency of Action	PRIORITY 3
Purpose of Action	LEVEL 2
Deficiency Photo1	
Violations	Room 450 No violations recorded.
<b>LIFE SAFETY</b>	Inspected
<b>F.D. HOLDING AREA</b>	Does not Exist
<b>STEEL STAIRS</b>	Does not Exist
<b>SITE</b>	Inspected
<b>CONTAINERIZATION</b>	Does not Exist
<b>Drainage System for Asphalt</b>	Does not Exist
<b>Drainage System for Concrete</b>	Inspected
<b>Catch Basins/Manhole - Surrounded by concrete</b>	Inspected
Condition	2 - Between Good and Fair
Deficiency	No deficiencies recorded
<b>Culverts - Concrete Covering</b>	Does not Exist
<b>Drainage System for Soil</b>	Inspected
<b>Catch Basins/Manhole - Surrounded by Soil</b>	Inspected
Condition	2 - Between Good and Fair
Deficiency	No deficiencies recorded
<b>Culverts - Soil Covering</b>	Does not Exist
<b>DRINKING FOUNTAINS</b>	Does not Exist



**NYC Department of Education  
Building Condition Assessment Survey 2023 - 2024**

Architectural Inspection

**K219**

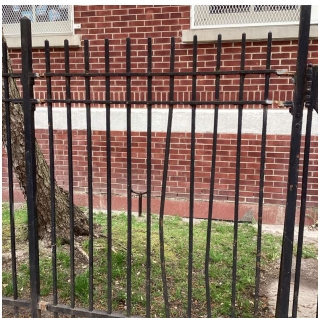
<b>Question</b>	<b>Response</b>
<b>SITE</b>	
<b>FENCES</b>	Inspected
Condition	4 - Between Fair and Poor
Deficiency	CHAIN LINK: DAMAGED POST/RAIL
Deficiency Location/Instance	E 93rd Street
Deficiency Quantity	10
Quantity Uom	L.F.
Potential Action	REPLACE
Urgency of Action	PRIORITY 3
Purpose of Action	LEVEL 2
Deficiency Photo1	
Violations	E 93rd Street No violations recorded.
Deficiency	WROUGHT IRON: DAMAGED/DETERIORATED
Deficiency Location/Instance	E 94th Street, E 93rd Street, Clarkson Avenue
Deficiency Quantity	1,040
Quantity Uom	S.F.
Potential Action	REPLACE
Urgency of Action	PRIORITY 3
Purpose of Action	LEVEL 2
Deficiency Photo1	
Violations	E 94th Street No violations recorded.
Deficiency	WROUGHT IRON: RUST - MAJOR
Deficiency Location/Instance	E 94th Street, Clarkson Avenue, E 93rd Street
Deficiency Quantity	160
Quantity Uom	S.F.
Potential Action	REPLACE
Urgency of Action	PRIORITY 3
Purpose of Action	LEVEL 2

**NYC Department of Education  
Building Condition Assessment Survey 2023 - 2024**

Architectural Inspection

K219

**Question**

**Response**

**SITE**

**FENCES**

Deficiency Photo1



E 94th Street

No violations recorded.

Violations

Deficiency

**CONCRETE CURB: DAMAGED/DETERIORATED**

Deficiency Location/Instance

E 94th Street, E 93rd Street

Deficiency Quantity

40

Quantity Uom

S.F.

Potential Action

REPLACE

Urgency of Action

PRIORITY 3

Purpose of Action

LEVEL 2

Deficiency Photo1

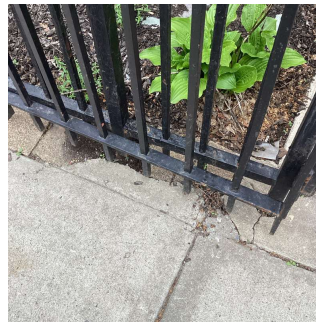

E 94th Street

No violations recorded.

Violations

Deficiency

**CHAIN LINK: DAMAGED/DETERIORATED**

Deficiency Location/Instance

E 93rd Street

Deficiency Quantity

100

Quantity Uom

S.F.

Potential Action

REPLACE

Urgency of Action

PRIORITY 3

Purpose of Action

LEVEL 2

Deficiency Photo1



E 93rd Street

No violations recorded.

Violations



**IRRIGATION SYSTEM**

Does not Exist

**NYC Department of Education  
Building Condition Assessment Survey 2023 - 2024**

Architectural Inspection

**K219**

<b>Question</b>	<b>Response</b>
<b>SITE</b>	
<b>IRRIGATION SYSTEM</b>	Does not Exist
<b>PAVING</b>	Inspected
<b>Student Non-Use</b>	Inspected
Gravel Exists?	Yes
<b>Asphalt</b>	Does not Exist
<b>Concrete</b>	Inspected
Condition	2 - Between Good and Fair
Deficiency	DAMAGED/DETERIORATED/MISSING SECTIONS
Deficiency Location/Instance	E 94th Street
Deficiency Quantity	25
Quantity Uom	S.F.
Potential Action	REPLACE
Urgency of Action	PRIORITY 3
Purpose of Action	LEVEL 2
Deficiency Photo1	
Violations	E 94th Street No violations recorded.
<b>Pavers</b>	Does not Exist
<b>Student Use</b>	Inspected
Gravel Exists?	No
<b>Asphalt</b>	Does not Exist
<b>Concrete</b>	Inspected
Condition	4 - Between Fair and Poor
Deficiency	DAMAGED/DETERIORATED/MISSING SECTIONS
Deficiency Location/Instance	Near Exits 9, 10, 11
Deficiency Quantity	675
Quantity Uom	S.F.
Potential Action	REPLACE
Urgency of Action	PRIORITY 3
Purpose of Action	LEVEL 2
Deficiency Photo1	
	Near Exit 11

**NYC Department of Education  
Building Condition Assessment Survey 2023 - 2024**

Architectural Inspection

**K219**

<b>Question</b>	<b>Response</b>
<b>SITE</b>	
<b>PAVING</b>	Inspected
<b>Student Use</b>	Inspected
<b>Concrete</b>	Inspected
Violations	No violations recorded.
<b>Pavers</b>	Does not Exist
<b>Site Sidewalks &amp; Walkways</b>	Inspected
<b>Asphalt</b>	Does not Exist
<b>Concrete</b>	Inspected
Condition	3 - Fair
Deficiency	HEAVING
Deficiency Location/Instance	Near Exit 7
Deficiency Quantity	75
Quantity Uom	S.F.
Potential Action	REPLACE
Urgency of Action	PRIORITY 3
Purpose of Action	LEVEL 2
Deficiency Photo1	
Violations	Near Exit 7 No violations recorded.
Deficiency	DAMAGED/DETERIORATED/MISSING SECTIONS
Deficiency Location/Instance	E 94th Street, E 93rd Street, Clarkson Avenue
Deficiency Quantity	375
Quantity Uom	S.F.
Potential Action	REPLACE
Urgency of Action	PRIORITY 3
Purpose of Action	LEVEL 2
Deficiency Photo1	
Violations	E 94th Street No violations recorded.
<b>Pavers</b>	Does not Exist
<b>DOT Sidewalk</b>	Inspected
<b>Asphalt</b>	Does not Exist

**NYC Department of Education  
Building Condition Assessment Survey 2023 - 2024**

Architectural Inspection

**K219**

Question	Response
<b>SITE</b>	
<b>PAVING</b>	
<b>DOT Sidewalk</b>	
<b>Concrete</b>	Inspected
Condition	3 - Fair
Deficiency	DAMAGED/DETERIORATED/MISSING SECTIONS
Deficiency Location/Instance	E 94th Street, E 93rd Street, Clarkson Avenue
Deficiency Quantity	350
Quantity Uom	S.F.
Potential Action	REPLACE
Urgency of Action	PRIORITY 4
Purpose of Action	LEVEL 4
Deficiency Photo1	
Violations	E 94th Street 52518
<b>Concrete</b>	
Deficiency	DAMAGED CURBS
Deficiency Location/Instance	E 94th Street, E 93rd Street
Deficiency Quantity	90
Quantity Uom	L.F.
Potential Action	REPLACE
Urgency of Action	PRIORITY 4
Purpose of Action	LEVEL 4
Deficiency Photo1	
Violations	E 94th Street 52518
<b>Pavers</b>	Does not Exist
<b>PLAYGROUNDS</b>	Does not Exist
<b>PLAYING SURFACE</b>	Does not Exist
<b>RETAINING WALLS</b>	Does not Exist
<b>SEATING</b>	Does not Exist
<b>SITE WALLS (NOT RETAINING WALLS)</b>	Does not Exist
<b>STAIRS/RAMPS: EXTERIOR</b>	Does not Exist
<b>ARTWORK</b>	Inspected
Instance	Interior - Missing - 71210

NYC Department of Education  
Building Condition Assessment Survey 2023 - 2024

Architectural Inspection

K219

Question	Response
<b>ARTWORK</b>	
Instance ID	71210
Artwork exist at stated location?	No