

PROCESS EQUIPMENTS



www.kerone.com



In Association with SVCH-Technologii, Moscow (Russia)

About KERONE

KERONE now renowned name in serving specialized need of customers with best quality and economical process Heating /cooling and drying products, manufactured in high quality environment by well trained and qualified workforce(special purpose machineries) .

KERONE is pioneer in application and implementation engineering with its vast experience and team of professionals. KERONE is devoted to serve the industry to optimize their operations both economically and environmentally with its specialized heating and drying solutions.

Vision

- Turn into world leader in providing specialized, top-notch quality and ecological industrial heating, cooling and drying solution across the globe.
- To attain global recognition as best of quality and environment friendly engineering solution company.

Mission

- To enhance the value of customer operation through our customer need centric engineering solution.
- We are committed to provide our customers, unique and best in class products in Industrial heating, drying and cooling segment, with strategic tie-up for the technical know-how with renowned leader in the industry specific segment.
- We are company that believes in strong ethics and timely commitment helps to build long term relationship.

Value Propositions

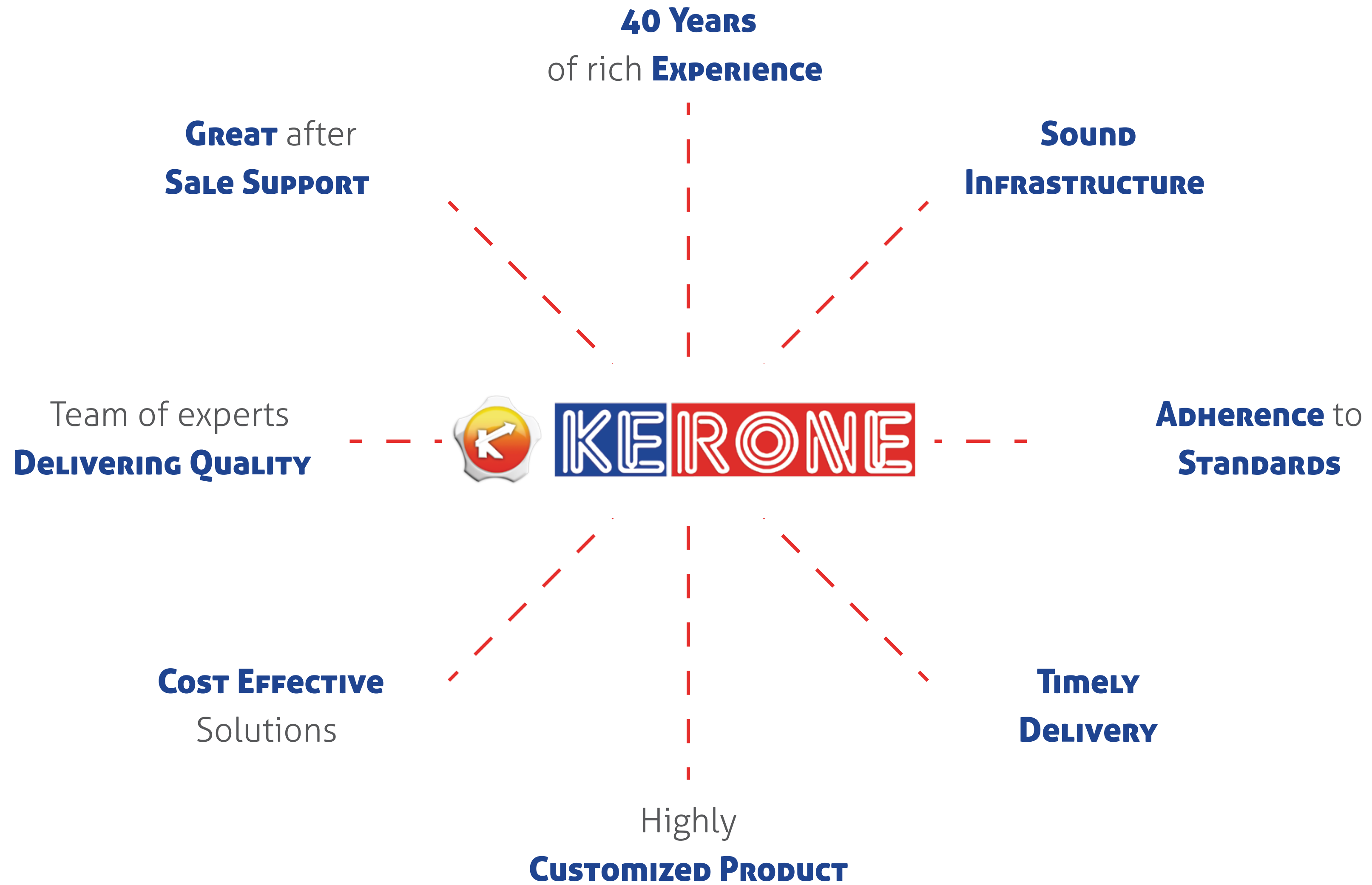

Introduction of Process Equipments

The Process Equipments/plants Are Usually Consisting Of The Following

REACTORS

FEEDERS

INDUSTRIAL DRYERS

MIXING PLANTS

CIP/SIP SYSTEMS

PILOT/LAB SCALE PLANTS

SCREW FEEDER/BLENDER

FILLING SYSTEMS

PROCESS PLANTS

BATCHING SYSTEM

POWDER TRANSFER SYSTEM

Process Equipments are arrangement of various mechanical equipments required for physical or chemical methods of mechanical and/or thermal treatment or processing of a raw material or product.

Process Equipment is usually designed with a specific process or family of processes in mind and can be customized for a particular facility in some cases.

Process Equipments are used in chemical and materials processing, in facilities like refineries, chemical plants, and wastewater treatment plants, pharmaceutical and other Industrial process engineering applications.

Reactors

Reactors are vessels designed to contain chemical reactions.

We Design and Manufacture Reactor for:

- ★ Chemical
- ★ Pharmaceutical
- ★ Petrochemical



Type of Reactors

- ★ Semi-batch reactor
- ★ Catalytic reactor
- ★ Batch reactor
- ★ PFR (Plug Flow Reactor)
- ★ CSTR (Continuous Stirred-Tank Reactor)

Feeders

Feeder guides the chemicals, materials and ingredients into a processing machine and equipment

We Design and Manufacture Reactor for:

- ★ *Pharmaceutical Feeder for feeding Ingredience*
- ★ *Loss-in-weight Feeder*
- ★ *Multi Stream Feeder*
- ★ *High Accuracy Volumetric Feeder for Chemical Processing*

Type of Feeders

- ★ *Continues Feeder*
- ★ *Batch Feeder*
- ★ *Volumetric Feeder*

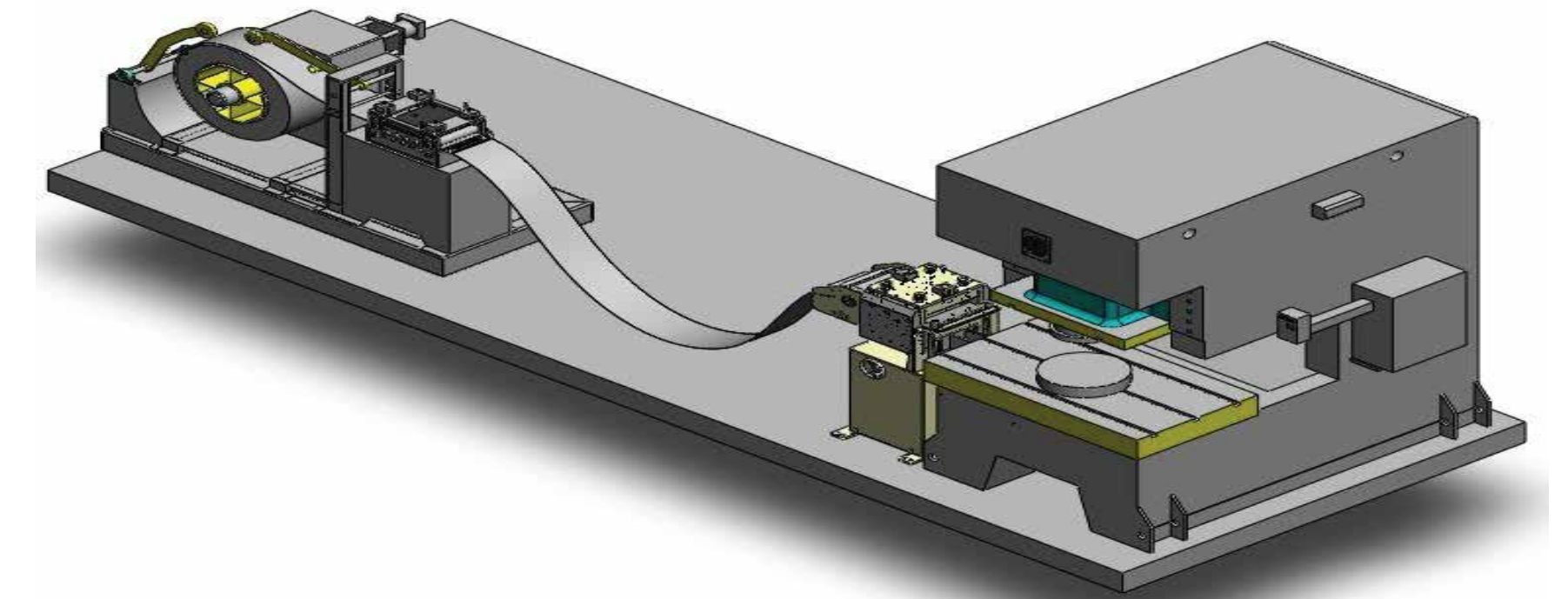

Industrial Dryers

Dryers find application where its desired to remove / reduce / take out moisture or water contents from the any article



Type of Industrial Dryers

- ★ *Microwave Dryers*
- ★ *Radio Frequency Dryers*
- ★ *Infrared Dryers*
- ★ *Conventional Dryers*
- ★ *Spray Drying*
- ★ *Hot Air Dryer*
- ★ *Contact Drying*
- ★ *Pneumatic/ Flash Dryer*
- ★ *Rotary Dryers*

Mixing Plants

Mixing reactors are very commonly used for the solids dissolution, product mixing, chemical reactions, batch distillation, crystallization, liquid/liquid extraction and polymerization



Application of the Mixing Plants

- ★ *Chemical Plants*
- ★ *Paint Manufacturing*
- ★ *Pharmaceutical Industries*

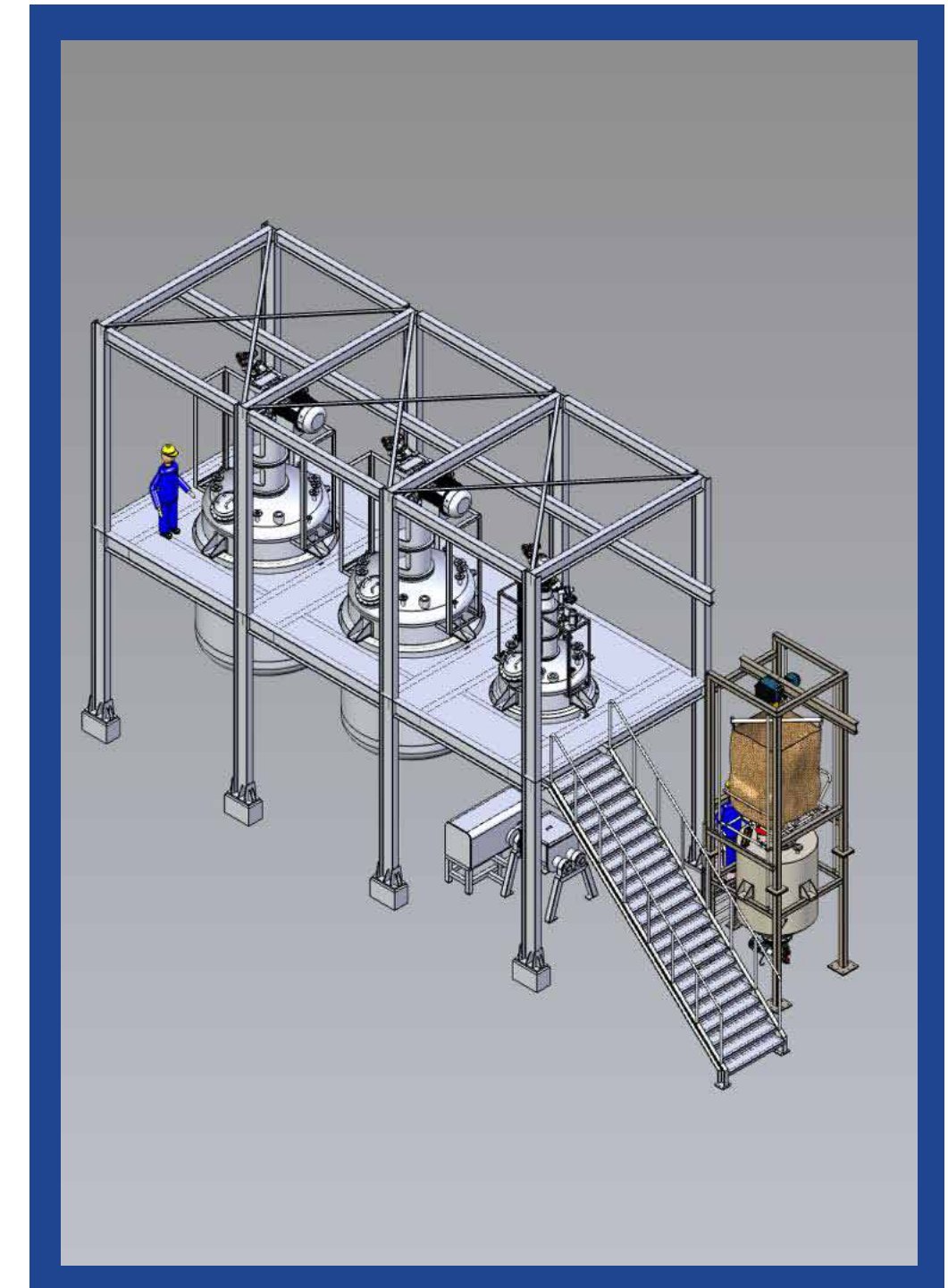

Process Plants

Process Plants are large scale manufacturing setup, the main objective of such setup is to help the companies involved in the large scale manufacturing process.



Industries with its Process Plants

- ★ *Chemical Plants*
- ★ *Pharmaceutical Plants*
- ★ *Biochemical Plants*
- ★ *Oil Refineries*
- ★ *Food And Beverages*

CIP/SIP Systems

The CIP/SIP systems together helps in maintaining the desired level of hygiene, by continuously killing the germs

CIP (Clean-in-Place) :

CIP (Clean-in-Place) systems offers the arrangement for cleaning/sterilising the interior surfaces of vessels, equipment, filters, pipes and fittings, without disassembly them.

SIP(Steam-In-Place) :

SIP(Steam-In-Place) Systems are liable for frequently steaming parts of product contact, vessels, flow paths, and sample ports.

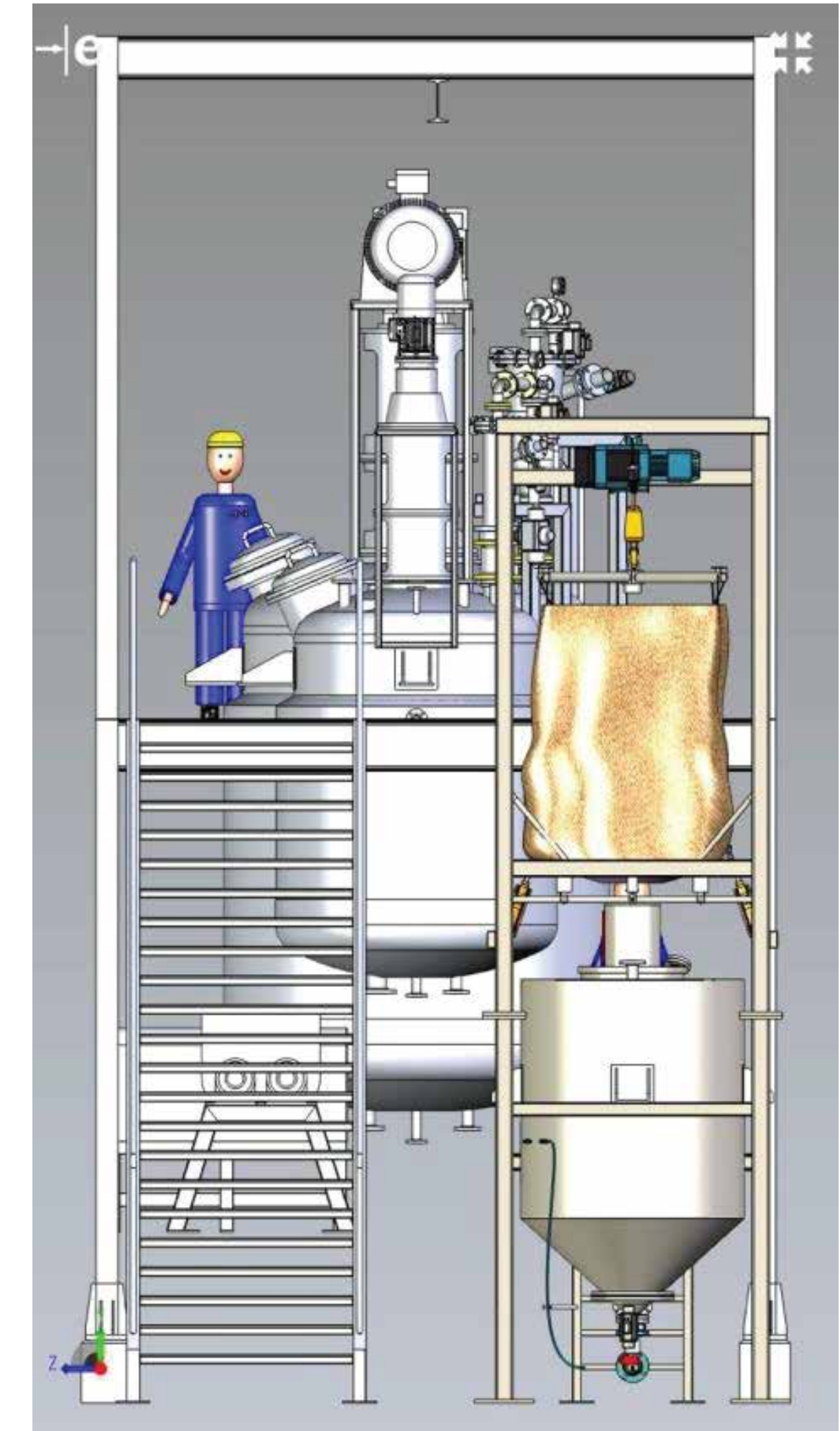
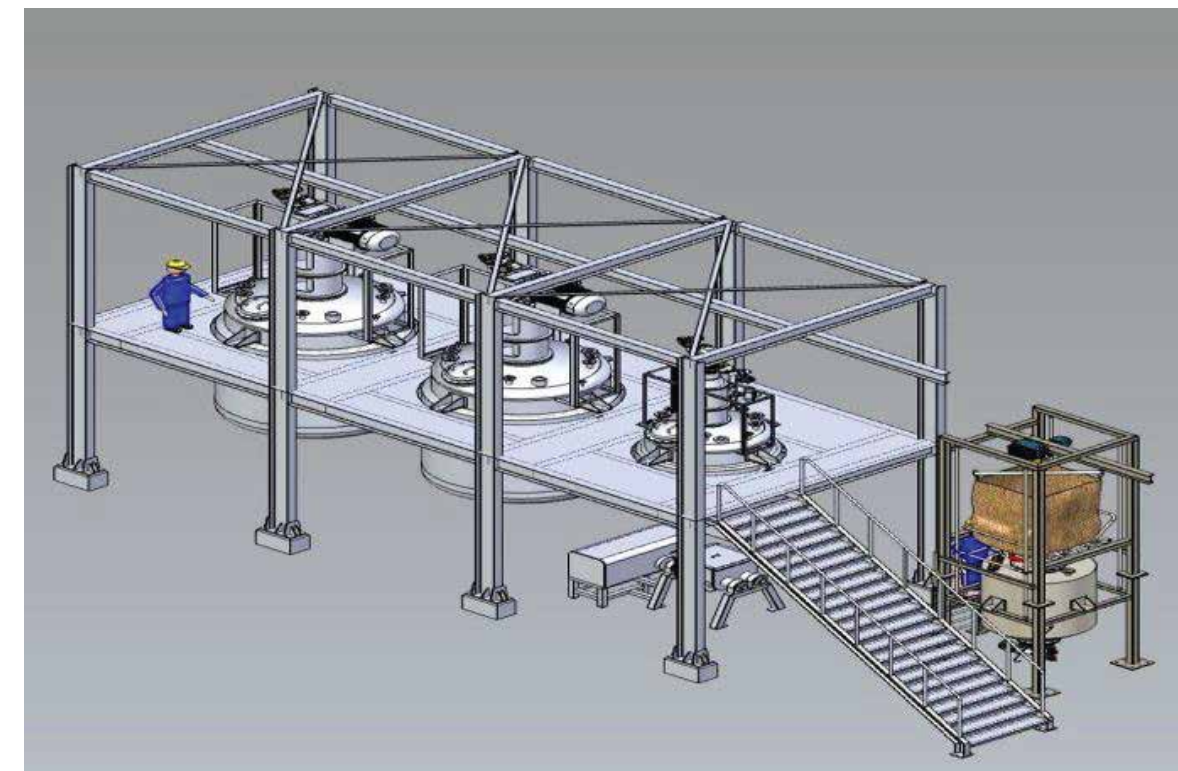
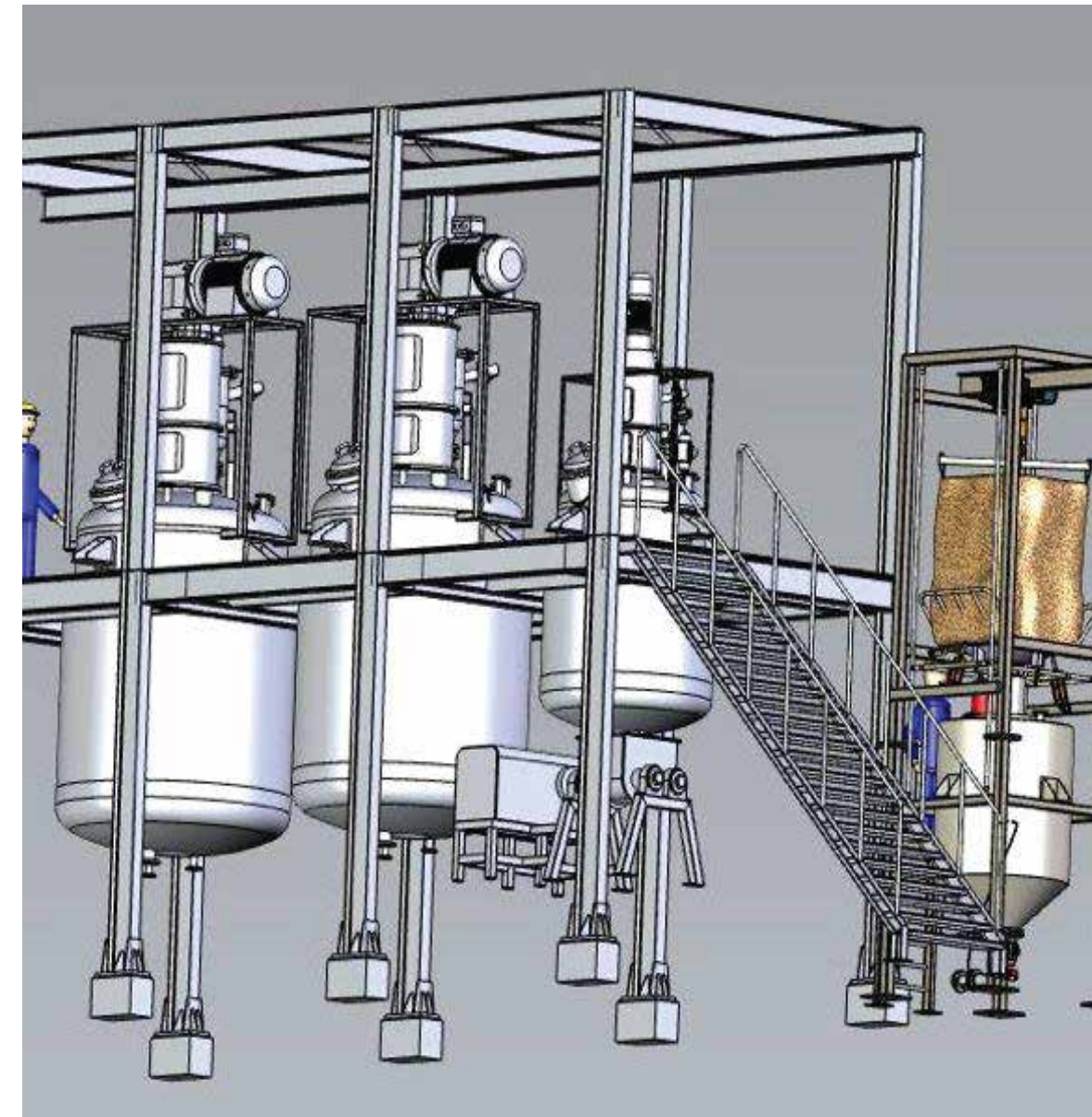

Powder Transfer Systems

The PTS Powder Transfer System is an extraordinarily efficient and dependable technique of conveying and dispensing dry and wet powders and granules.

Main Components :

- A vacuum conveying system utilizing Roots Blower, Modular construction equipment.
- Jet Air Wand with Air regulating Damper.
- Jet Air Wand fitted with stainless steel wire mesh to stop foreign particles entry in to process.
- Entire transfer through electro polished pipe with curvilinear bends and isolating valves both manual and pneumatically actuated.
- Suitable filters pleated 5 micron in the product unloading chamber, pulse jet type for inside cleaning.

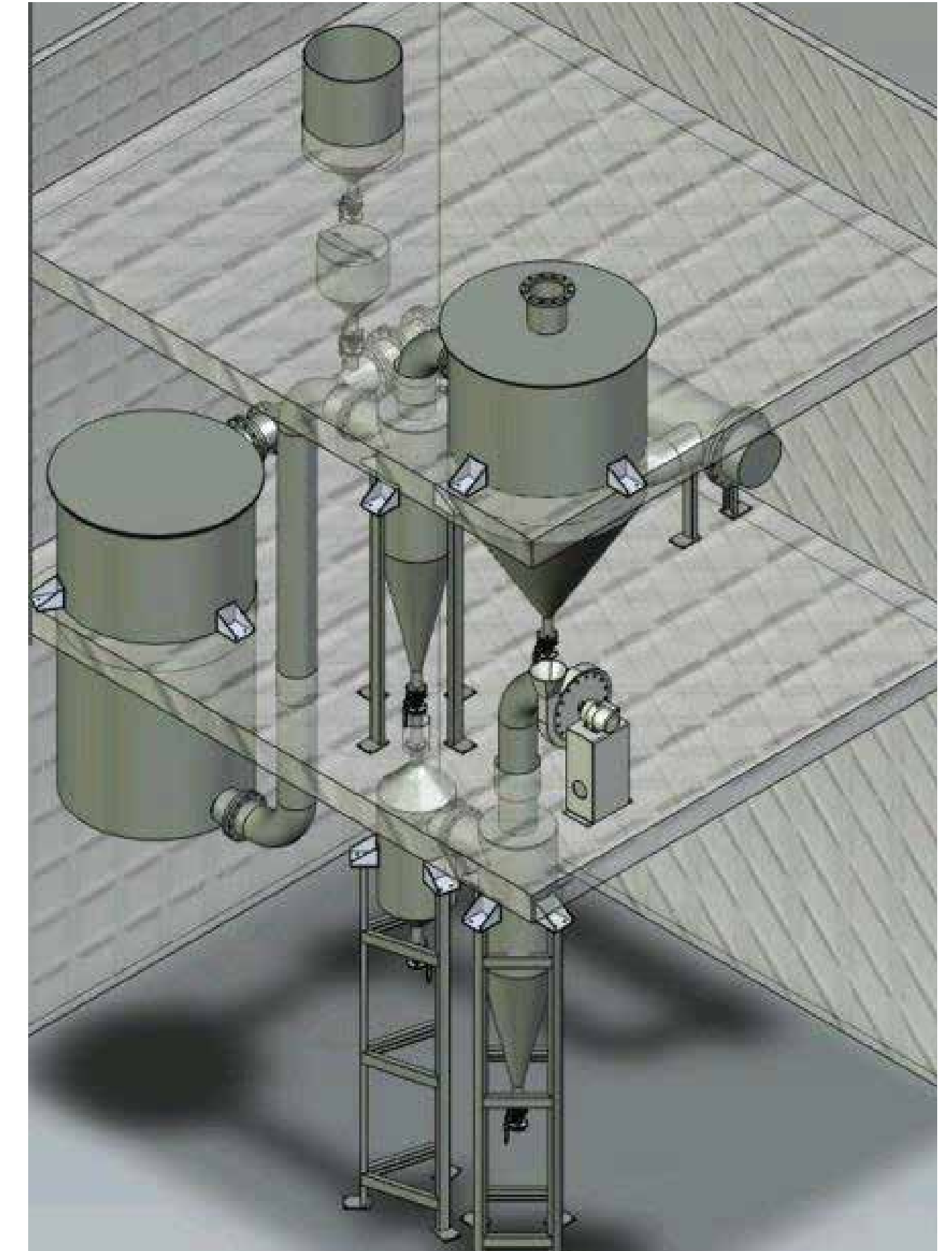

Batching Systems

A batching system is batch operating production process, in this production occurs in sequential steps in discrete batches.



Pilot / Lab Scale Plants

PILOT Scale Plant

Pilot scale process equipments are for small industrial system, which is operated as the subset of the full-fledged industrial machinery. Pilot scale process equipments are just replica of the large scale process equipment only difference is the size and input capacity which is comparatively less.

Lab Scale Plant

Lab scale process equipments are very small scale processing such as R&D and laboratory experiments, the lab scale process equipments are made to provide the high level of accuracy. As the name suggests the lab scale process equipments are comparatively smaller in size and capacity but are equipped with the high degree of control and various experimental setting



Skid Mounted Process Units

- ★ *Single Fluid Heating System*
- ★ *Hot Water Systems*
- ★ *Skid Mounted Reaction Unit*
- ★ *Fractional Distillation*

Single Fluid Heating System

Single fluid heating cooling system is normally connected to a single reactor, where the Temperature of the system is varied as per the process requirement.



Hot Water Systems

The Hot Water System is available for use with plant steam or electricity as the heat source. Both steam and electric units come in single and dual zone configurations.

Skid Mounted Reaction Unit

Expensive and high-grade products are not produced in large quantities, as they are typical for pharmaceutical industry, & also for fine/special chemical areas.



Fractional Distillation

We design Many types of Distillation Operations could be carried out in the system like as Simple Distillation, High Vacuum Distillation, Fractional Distillation, Azeotropic Distillation

Cyclone Separator

Cyclone Separator is used to separate the solids from the air, gas and liquids without any filter.

OPERATING PRINCIPLE :

Cyclone separator operates on the principle of the centrifugal force. The separation depends on both the particles size and the density of the particles.

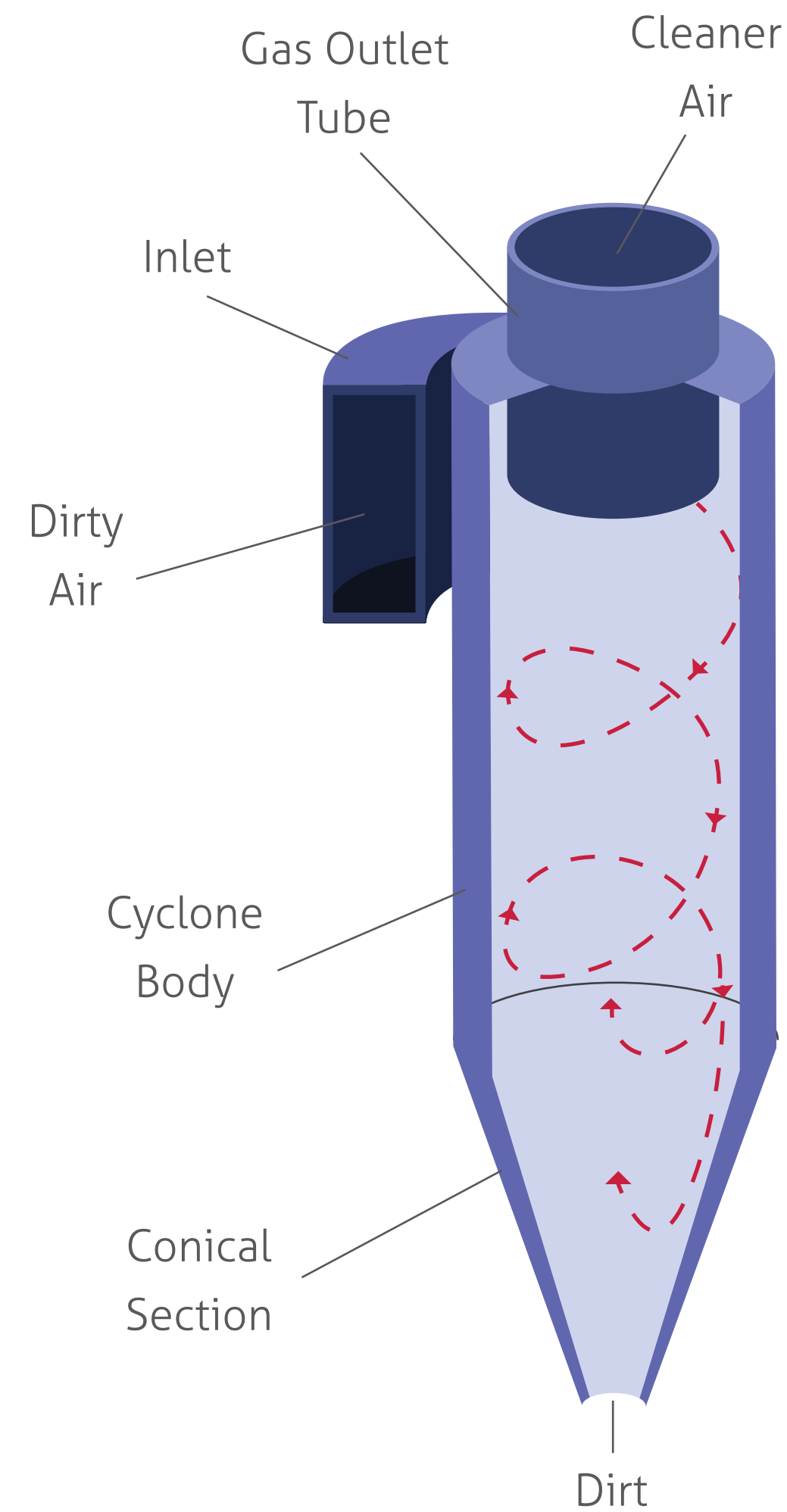

- ↓ The suspensions of a solid gas usually air is introduced tangentially at a very high velocity so that rotary movement takes place within the vessel.
- ↓ The fluid is removed from the central outlet at the top.
- ↓ The rotary flow within the cyclone separator causes the particles to be acted on by centrifugal force
- ↓ The solids are thrown out to the walls, there after it falls to the conical base and discharged out through solids outlet

Bag House Filter

The Bag house or fabric filter is an air pollution controlling mechanical setup; it removes the contaminations from the air/gas released from the industrial processes.

- ★ Mechanical Shaker Baghouse
- ★ Reverse Air Baghouse
- ★ Reverse Jet Baghouse

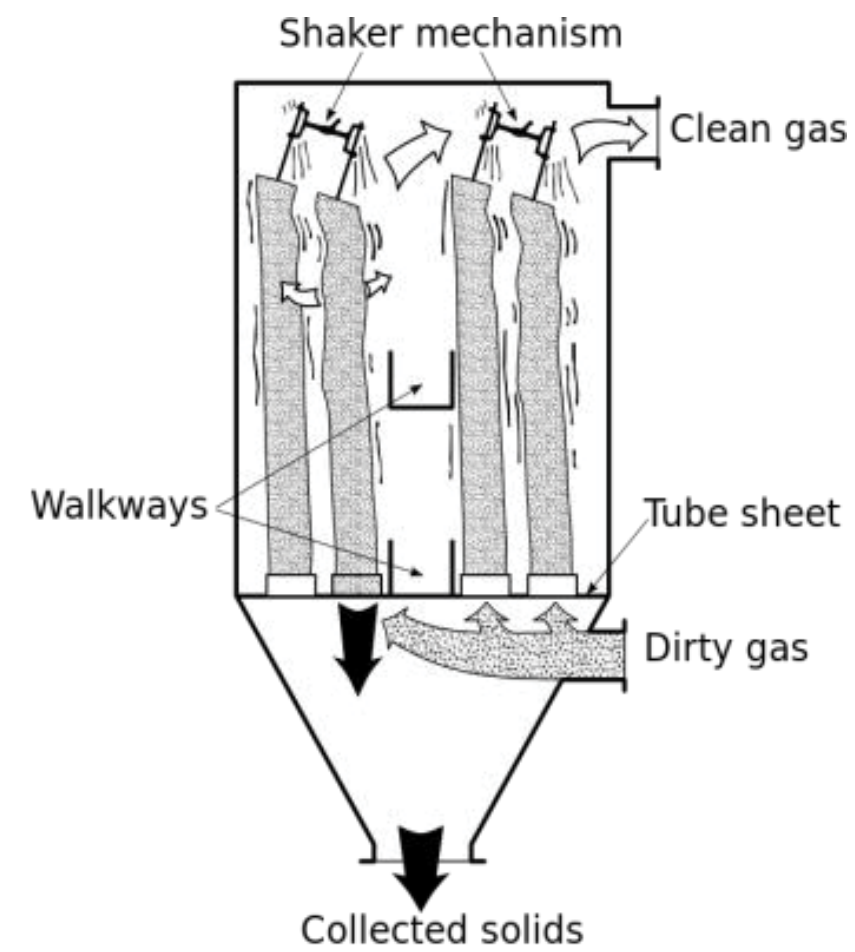

Mechanical Shaker Baghouse

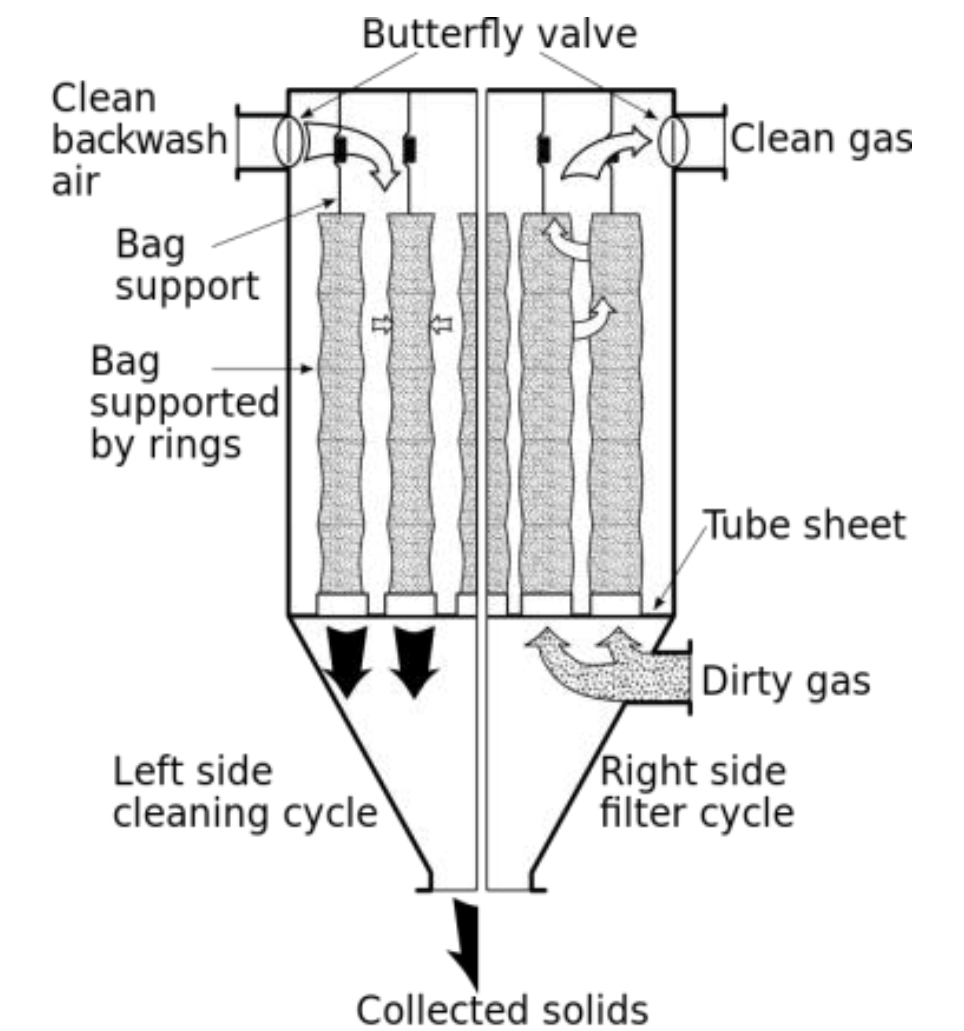

Reverse Air Baghouse

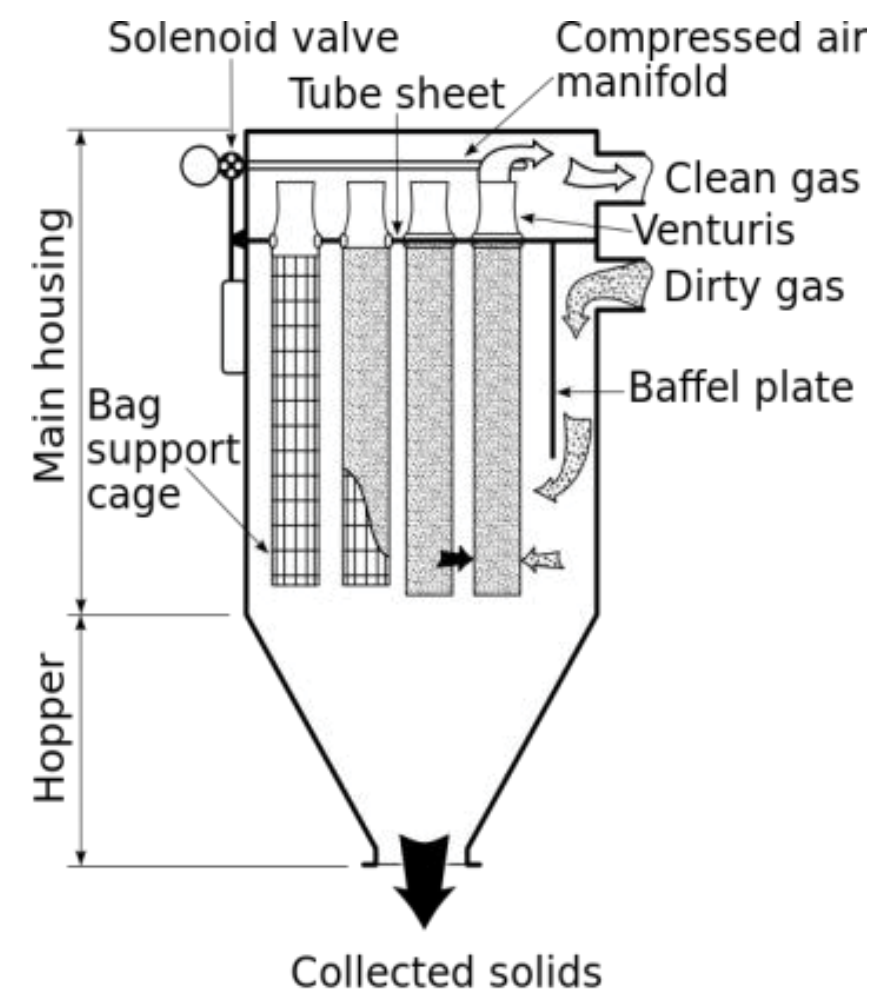

Reverse Jet Baghouse

Trusted Partner



Our Clients

UNIT I

B/10,Marudhar Industrial Estate, Goddev Fatak
road, Bhayander(E), Mumbai-401105

Phone : +91-22-28150612/13/14

UNIT II

Plot No. B-47, Addl. MIDC Anandnagar,
Ambarnath (East), Dist. Thane- 421506

Phone : +91-251-2620542/43/44/45/46

EMAIL

info@kerone.com | sales@kerone.com | unit2@kerone.com

WEBSITE

www.kerone.com | www.kerone.net | www.keroneindia.com



www.kerone.com